

Product Catalog 2025/2026

Round and V-belts | monolithic conveyor belts | slip-free belts
Flat belt accessories | coatings | welding equipment



Edition 2025/2026

The specifications

in this catalog are based on our current knowledge and experience. They do not acquit the processor from testing our products at its own due to the plenty of possible effects during processing application of our products. The legally binding confirmation of certain properties or of the qualification for a certain purpose can not be derived from our specifications. Possible trade mark rights as well as existing laws and regulations are to be followed by recipient of our products at his own responsibility.

Terms and conditions

Our terms and conditions can be found on our homepage under the following link:
<http://www.behabelt.com>

Changes

for the benefit of technical enhancements respectively adoption to modified standards or provisions are provided.

Pictures

in this catalogue are examples of types and are not binding for the type at the time of delivery.

CONTENT

4

ABOUT US

Company // Product groups // Product brands // smart conveying // Fairs, Social Media
Customer Support // Innovations

12

BELT PROFILES MADE OF PU AND TPE

Round belts // Hollow round belts // Can Cables // Twisted round belts // V-belts
Covered V-belts // Twin-V-belts // Ridge-top-V-belts // T-Profiles // Special profiles
Coatings and embossings for profiles

57

ELASTIC MONOLITHIC CONVEYOR BELTS

Overview structures // Product features // Slip-free conveyor belts
Conveyor belts up to 730 and 140 mm

73

PU COATING MATERIAL

Coating thickness from 1 - 4 mm // Hardness range from Shore 45A to 95A
Coating width from 140 - 730 mm

77

WELDABLE ACCESSORIES FOR CONVEYOR BELTS

V-guides // Cleats // Sidewalls // Belt edges // PU sheets

92

BELT FABRICATION & JOINING

Express service fabrication // Overview joining options // Mechanical joints

97

WELDING TOOLS

Friction welding machines // Hot paddle welding tools // Hot presses // Guide clamps
Welding unit for conveyor belts // Accessories & Spare parts // Mandrel welders

120

KNOW-HOW

Know-how PU and TPE // General directives for plastics // Pulley design //
Guiding concepts for belts AT5 // Pretension // Calculation examples // Technical tables



About us

Beha Innovation GmbH is a German company based in the heart of Europe. With a global market presence, a subsidiary in the USA and a worldwide distribution network, we serve our customers promptly and competently. True to our motto

‘smart conveying’, we have been manufacturing innovative products for drive and conveyor technology since 1974. Our profiles, belts and welding technology are tailored to market requirements.

People, quality and innovation – the pillars of our success

People are at the heart of everything we do: our employees, customers and suppliers. They are the foundation for a trusting, cooperative and long-term partnership. The highest quality – both in the raw materials we use and in our careful manufacturing processes – is just as important to us as reliable, open and transpar-

ent communication. On this basis and through our close, practical cooperation with customers and suppliers, we continuously develop new, innovative products and tailor-made solutions that create real added value.



A family business

We are a manufacturer

BEHAbelt always strives to offer its customers high-quality and innovative solutions.

One of the keys to our success lies in the close cooperation between our sales and technical departments. The belt profiles and belts are extruded and calendered at our headquarters in Glottertal in the Black Forest.

Thanks to short communication channels, we are able to respond quickly to customer requests.

In addition to the high quality of our products, delivery times and responsiveness are top priorities in terms of customer service.



We are fabricator

In addition to manufacturing high-quality polyurethane belt profiles and conveyor belts, BEHAbelt offers comprehensive finishing and assembly services. As an experienced partner, we tailor our products precisely to the specific requirements of our customers – for maximum functionality and durability in use.

For belt profiles, our services include precise butt splicing – with or without reinforcement – the application of coatings, individual embossing, perforation, notching and professional labelling.

For conveyor belts, we offer customised cut-to-width services, the welding of guide profiles or corrugated edges, and various labelling options.

With state-of-the-art technology and high quality standards, BEHAbelt ensures that every product is optimally prepared for its application.



About us

The five product groups of BEHAbelt

Since 1974, we have been working with weldable components made of PU and TPE for conveyor and drive technology. We always tailor our products and services to market experience and requirements. We believe that regular dialogue with customers and interested parties is the basis for product innovation. The challenges and trends in these industries have grown over the years and become much more diverse. To better focus on these requirements, we have formed five product groups, which we present below.

Conveyor belts

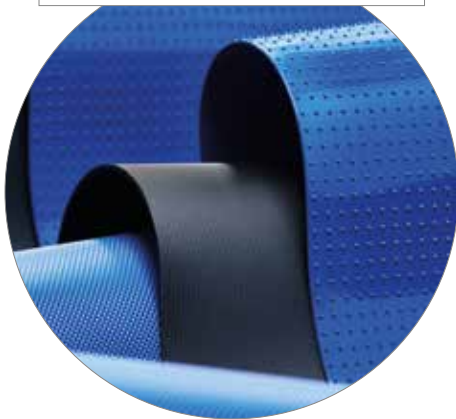

Monolithic conveyor belts made of PU and TPE

We are one of the leading manufacturers offering a huge combination of options. Choose your surface structure, material properties, hardness and colors.

Belt profiles



Weldable PU and TPE belts

BEHAbelt offers one of the broadest ranges in the market. This includes the number of geometries, material properties and shore hardness variations. In addition, we are able to develop and manufacture customized profiles.

Welding technology



Welding technology for PU and TPE

„Each belt is only as good as its splice.“ Our program includes specially developed welding tools for profiles and flat belts.

Coatings



PU coatings for timing belts and V-belts

Coating materials for e.g. high grip, accumulating or easy release. The industry requirements are as varied as our offer.

Weldable profiles



Weldable profiles made of PU

The assembly of conveyor belts with weld-on profiles such as cleats, sidewalls or V-guides allow solutions to a wide range of applications.

BEHAbelt product labels

Within the product groups of belt profiles, coatings and conveyor belts, we use product labels to identify products with special properties.

Special features of belt profiles and conveyor belts

PU soft

describes a highly flexible, non-slip and wear resistant compound for profiles with a hardness of 65° Shore A. Perfectly suited for applications that require smallest pulley diameters. PUsoft is often used as a silicone alternative.

PU plus

is a special material composition for elevated load capacity and reduced elongation with the same product design and unchanged pulley diameters, compared to products made of standard PU compounds.

PU safe

identifies metal and X-ray detectable conveyor belts and profiles. The food industry is increasingly using detectable profiles and belts as additional safety measure to prevent contamination of foodstuff with foreign objects.

Special features of coatings and weldable profiles

PU tex

coatings made of these unique PU compounds are fully weldable with the base material and therefore protected against delamination. Due to the high grip they are perfect alternatives to rubber coatings.

PU grip

is our softest coating material. At 45°/60° Shore A hardness it ensures best grip and flexibility. Like all PU coatings, it can be perfectly welded to PU V-belts or timing belts.

PU flex

specifies our extremely flexible sidewalls due to the very small wave pitch. Sidewalls are often used with cleats on conveyors for inclined transport to prevent spillage.

smart conveying

We understand our mission statement as continuous motivation. For us, it means that we always take a critical look at conveying and power-transmission processes. Together with our customers and partners, we want to have constructive conversations to optimize their applications. Doing this, we ensure to develop products and services that will deliver benefits in the target applications.

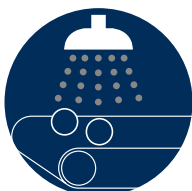

Washing



Picking

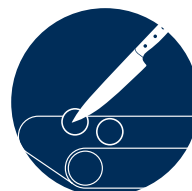

Cutting

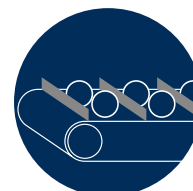

Portioning

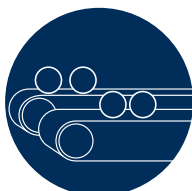

Sorting



Checking



Weighing

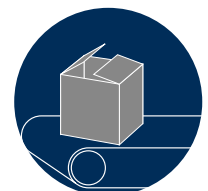

Packing

Contact

Social Media

We regularly publish information via the most common social media platforms, such as Facebook or LinkedIn. On LinkedIn we focus mainly on product innovations, event announcements and tips and tricks. On Facebook we also share photos and reports about our social activities. On the BEHAbelt-TV YouTube channel you will find videos describing and demonstration our most important welding machines. We are looking forward to your visit!



Exhibitions

Participation in trade fairs gives us the opportunity to explain our products individually to customers and evaluate the optimal solution for their specific application. You will find us regularly at the following trade fairs. On request you will receive free trade fair tickets from us.



Tutorial videos with BEHAbelt welding technology on YouTube

„Every belt is only as good as its splice“. This fact has always been our drive for the development of special welding technology for profiles and belts. But not only the technology alone, but also the professional application is a guarantee for process-safe connections. On our YouTube channel „BEHAbelt“ we provide you with videos that show you in detail the correct operation of the technology. This way you can ensure that the joining of profiles and belts prevents long downtimes.



Contact

Customer support



Lauren Magana

Phone: +1 630 521-9835

Fax: +1 630 521-9836

lauren.magana@behabelt.com



J. Skii Reid

Phone: +1 630 521-9835

Fax: +1 630 521-9836

skii.reid@behabelt.com



Subscribe to the BEHAbelt Newsletter

The free BEHAbelt-Newsletter is published 3 times a year and informs about news and trends in the field of conveyor and power-transmission belts as well as our participation in events. We look forward to your registration.

Visit our website: www.behabelt.com

On our website you will find many details about the BEHAbelt products. In addition to this information, events and news are also listed. There is also the possibility to order product samples in a very easy manner.



Innovations



Positive driven AT5/PU95A belts for hygienic transport of even heavy block goods

In addition to the proven AT5/PU80A belts, which are ideal for lighter conveyor goods, the new AT5/PU95A conveyor belts offer significantly increased mechanical strength. The harder PU95A cover layer has been specially developed for transporting heavy block goods such as cheese blocks, sausage sticks or other raw products. The higher Shore hardness (95A) effectively prevents the belt from stretching or deforming, even under high loads.

The AT5/PU95A belt really shows its strengths in feed systems where heavy products have to be transported continuously and precisely. The hygienic design, the compliant material selection for food contact (in accordance with FDA/EC guidelines) and the easy cleanability make these conveyor belts the ideal solution for demanding applications in the food processing industry. **Page 63**



Welding technology for belt edges

More stable processes with curved belts: BEHAbelt's welding technology for belt edges connects the belt ends, ensuring consistent guide stability and preventing premature material fatigue at the connection point.

This simple weld eliminates the potential weak point caused by unconnected belt edge ends. **Page 104**



Longer battery life: RS02 AKKU

New motor, more power: The unique RS02 AKKU friction welding machine has been improved. The new, more powerful battery enables 20% more welding operations (approx. 200) and the new brushless motor extends the service life.

The new batteries are compatible with previous RS02-AKKU models. **Page 98**

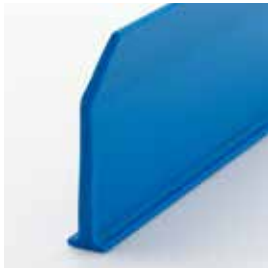

Angled cleats

Our cleats for incline conveyors offer greater process reliability and impress with their excellent weldability and long service life.

Available in standard sizes 40 and 50 mm, other versions (30 and 60 mm) on request.

Naturally food-grade in accordance with FDA and EC regulations.

Page 87



Metal and X-ray detectable

New compound mix: Following an intensive development phase in collaboration with leading metal and X-ray detector manufacturers, we are now pleased to present our improved 'PU-safe' product category.

This FDA/EC-compliant product range, which includes round belts, V-belts, conveyor belts and weld-on profiles, offers a 30% increase in detectability.

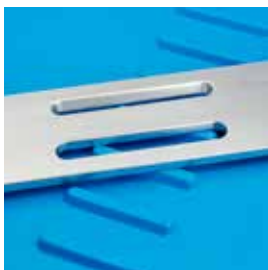

HS800: New adapter plates

Connect SuperDrive™, CleanDrive and ThermoDrive conveyor belts precisely with the new adapter plates. These have been specially developed and designed for the BEHAbelt HS800 welding unit.

This range is constantly being expanded. On request, we can check the feasibility of special additional adapter plates and provide a quote. **Page 114**



Joining table with 70° angle splice

The optionally available 70° joining table for angle splice connections on PU conveyor belts offers maximum precision and quality. This angle splice increases the welding surface, ensuring a particularly strong and durable connection. At the same time, the 70° joint enables a smooth transition in the belt run, which noticeably reduces vibrations and mechanical stress during operation.

Page 114



Product feature 'vegan'

Our belt profiles and conveyor belts with this label are completely vegan and contain no animal ingredients whatsoever.

They are made from plant-based or synthetic materials and meet the highest hygiene standards. This makes them ideal for use in sensitive production areas such as vegan and vegetarian food processing.



All data sheets on the website

Technical data sheets for all belt profiles and conveyor belts can now be conveniently downloaded from the BEHAbelt website. And they are even available in the respective national language.

The desired products can also be added to a watch list and sent to our sales department for quotation.

www.behabelt.com



CONVEYOR BELT PROFILES MADE OF PU AND TPE

Table structure key	13
Round belts, Hollow round belts	14
Can Cables	29
Twisted round belts	31
V-belts	32
Coatings and embossings for profiles.....	39
Twin V-Belts	40
Ridge-top V-belts	42
T-Profiles.....	44
Special profiles / Special V-belts.....	49
Custom-made profiles.....	56

General explanation of the product tables

② PU85A green rough, reinforced aramid

Order No.	⑦ Diameter \varnothing		⑧ approx. weight	⑨ Standard roll		⑩ Recommended min. pulley \varnothing		⑪ PT/DRIVE Fmax/belt		⑫ CONVEYANCE max. conveying weight			
	mm	inch	kg/100m	m	ft	mm	inch	Standard	Overlap	Standard		Overlap	
								N	N	kg	lbs	kg	lbs
① BZR85A060RA	6,0	7/32	3,4	100	328	60	2,3	57	176	11.3	24.9	35.2	77.7
FBZR85A063RA	6,3	1/4	3,8	100	328	65	2,5	62	177	12.5	27.5	35.5	78.1
FBZR85A070RA	7,0	9/32	4,7	100	328	70	2,8	77	180	15.4	33.9	36.0	79.4
FBZR85A080RA	8,0	5/16	6,0	100	328	80	3,2	101	293	20.1	44.3	58.7	129.3
FBZR85A095RA	9,5	3/8	8,5	100	328	95	3,7	142	301	28.4	62.5	60.2	132.7

③  approx. 88° Shore A

④ Max. pretension

Standard	1,5 %
Overlap	1,5 %











⑥ approx. Coefficient of friction μ : Steel: 0,45 | PE: 0,35 | HDPE: 0,30

Key

- ① BEHAbelt item/order number (availability, delivery time and minimum order quantity on request)
- ② BEHAbelt material type Quality (product name)
- ③ Color (please note that the original colour may differ from the graphic)
- ④ Shore hardness (PLEASE NOTE: BEHAbelt product designation does not correspond to the Shore hardness of the belt)
- ⑤ Max. pre-tension of the belt in the system (in %)
- ⑥ Approx. coefficient of friction μ on steel, PE and HDPE substrates (see also Coefficient of friction on page 130)
- ⑦ Profile geometry in mm
- ⑧ Approx. weight in kg for 100 m of the corresponding profile geometry
- ⑨ Standard roll = production unit (smaller quantities available at extra charge). Special roll sizes available on request.
- ⑩ Recommended minimum pulley diameter (in mm) measured in neutral fibre. Smaller pulley diameters are possible but may shorten the service life of the belt.
- ⑪ Max. pull force of the belt (tangential force) in the drive case for butt and overlap welding, specified in N/belt. Overlap welding using hot press process HP01, overlap length 60 mm.
- ⑫ Max. conveying weight of the belt for butt and overlap welding, specified in kg/belt. The values specified are based on a coefficient of friction of $\mu=0.5$ and the max. recommended pretension setup. This must be adjusted to the conditions in the system if necessary (see also friction values on page 130); overlap welding using hot press method HP01, overlap length 60 mm.

Table values valid at ambient conditions of 20°C ±10°C. (otherwise minimum pulley diameter, pretension and max. load of the belt have to be adjusted)

Symbols

									
Antistatic profile with excellent mechanical properties.	Particularly cold-resistant profile down to -30°C.	Patented 'PLUS' material mix for lower product elongation.	Particularly good UV protection.	Profiles with FDA/EC conformity for direct contact with food.	Use of raw materials from non-animal sources.	Metal and X-ray detectable profiles for maximum food safety.	Hydrolysis resistance (HY). Suitable for humid environments.	Microbe-resistant materials do not provide a breeding ground for microorganisms.	2-component belt enables combination of hardness and properties.

Round belts | Shore 65 A, 76 A

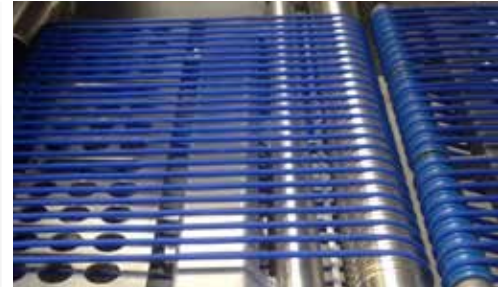

Round belts

Weldable round belts made of PU and TPE are available in various Shore hardnesses and diameters for the transport and drive industries. Typical industries include: food, logistics, printing & paper, packaging, building materials and many more.

PU60A **soft** blue smooth



Order No.	Diameter \varnothing		approx. weight kg/100m	Standard roll		Recommended min. pulley \varnothing		PT/DRIVE Fmax/belt Standard N	CONVEYANCE max. conveying weight Standard	
	mm	inch		m	ft	mm	inch		kg	lbs
FBRF030LGS	3,0	1/8	0,9	200	656	10	0,4	5	1,0	10,9
FBRF040LGS	4,0	5/32	1,6	200	656	20	0,8	9	1,8	3,9
FBRF050LGS	5,0	1/5	2,2	100	328	30	1,2	14	2,7	6,1
FBRF060LGS	6,0	7/32	3,4	100	328	35	1,4	20	4,0	8,7
FBRF080LGS	8,0	5/16	6,0	100	328	45	1,8	35	7,0	15,5
FBRF095LGS	9,5	3/8	8,5	100	328	60	2,4	50	9,9	21,9
FBRF100LGS	10,0	7/16	9,4	50	164	65	2,6	55	11,0	24,2

approx. 65° Shore A

Recommended pretension 5...10 %

approx. Coefficient of friction μ : Steel: 1,0 | PE: 0,75 | HDPE: 0,65

PU65A ultramarine blue smooth



Order No.	Diameter \varnothing		approx. weight kg/100m	Standard roll		Recommended min. pulley \varnothing		PT/DRIVE Fmax/belt Standard N	CONVEYANCE max. conveying weight Standard	
	mm	inch		m	ft	mm	inch		kg	lbs
FBRP65A040UB	4,0	5/32	1,6	200	656	22	0,9	10,0	2,0	4,5
FBRP65A050UB	5,0	1/5	2,2	100	328	32	1,3	15,7	3,1	7,0
FBRP65A060UB	6,0	7/32	3,4	100	328	40	1,6	22,6	4,5	10,1

approx. 72° Shore A

Recommended pretension 4...8 %

approx. Coefficient of friction μ : Steel: 0,85 | PE: 0,65 | HDPE: 0,55

PU70A ultramarine blue smooth



Order No.	Diameter \varnothing		approx. weight kg/100m	Standard roll		Recommended min. pulley \varnothing		PT/DRIVE Fmax/belt Standard N	CONVEYANCE max. conveying weight Standard	
	mm	inch		m	ft	mm	inch		kg	lbs
FBRH030LG	3,0	1/8	0,9	200	656	15	0,6	6	1,2	2,7
FBRH040LG	4,0	5/32	1,6	200	656	25	1,0	11	2,2	4,9
FBRH048LG	4,8	3/16	2,2	200	656	30	1,2	16	3,2	7,0
FBRH050LG	5,0	1/5	2,2	100	328	35	1,4	17	3,5	7,6
FBRH060LG	6,0	7/32	3,4	100	328	45	1,8	25	5,0	11,0
FBRH080LG	8,0	5/16	6,0	100	328	55	2,2	44	8,8	19,5

approx. 76° Shore A

Recommended pretension 4...8 %

approx. Coefficient of friction μ : Steel: 0,75 | PE: 0,50 | HDPE: 0,45

PU75A red smooth



Order No.	Diameter Ø		approx. weight kg/100m	Standard roll		Recommended min. pulley Ø		PT/DRIVE Fmax/belt Standard N	CONVEYANCE max. conveying weight Standard	
	mm	inch		m	ft	mm	inch		kg	lbs
FBRP75A020	2,0	5/64	0,5	200	656	10	0,4	4	0,9	1,9
FBRP75A030	3,0	1/8	0,9	200	656	20	0,8	10	1,9	4,2
FBRP75A040	4,0	5/32	1,6	200	656	30	1,2	17	3,4	7,5
FBRP75A048	4,8	3/16	2,2	200	656	35	1,4	25	4,9	10,8
FBRP75A050	5,0	1/5	2,4	100	328	40	1,6	27	5,3	11,8
FBRP75A060	6,0	7/32	3,4	100	328	50	2,0	38	7,7	17,0
FBRP75A063	6,3	1/4	3,8	100	328	55	2,2	42	8,5	18,7
FBRP75A070	7,0	9/32	4,7	100	328	60	2,4	52	10,5	23,1
FBRP75A080	8,0	5/16	6,0	100	328	65	2,6	68	13,7	30,1
FBRP75A095	9,5	3/8	8,5	100	328	75	3,0	96	19,3	42,5
FBRP75A100	10,0	7/16	9,4	50	164	80	3,2	107	21,4	47,1
FBRP75A120	12,0	15/32	13,5	50	164	90	3,5	154	30,8	67,8
FBRP75A125	12,5	1/2	14,8	50	164	100	3,9	167	33,4	73,6
FBRP75A150	15,0	19/32	21,5	50	164	120	4,7	240	48,1	105,9
FBRP75A180	18,0	3/4	31,0	50	164	150	5,9	346	69,2	152,6
FBRP75A200	20,0	25/32	40,0	50	164	170	6,7	427	85,5	188,3

approx. 80° Shore A

Recommended pretension 4...8 %

approx. Coefficient of friction μ : Steel: 0,70 | PE: 0,40 | HDPE: 0,35

PU75A sky blue smooth

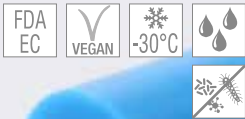

Order No.	Diameter Ø		approx. weight kg/100m	Standard roll		Recommended min. pulley Ø		PT/DRIVE Fmax/belt Standard N	CONVEYANCE max. conveying weight Standard	
	mm	inch		m	ft	mm	inch		kg	lbs
FBRP75A020HI	2,0	5/64	0,5	200	656	10	0,4	4	0,8	1,7
FBRP75A030HI	3,0	1/8	0,9	200	656	20	0,8	8	1,7	3,7
FBRP75A040HI	4,0	5/32	1,6	200	656	30	1,2	15	3,0	6,6
FBRP75A048HI	4,8	3/16	2,2	200	656	35	1,4	22	4,3	9,6
FBRP75A050HI	5,0	1/5	2,4	100	328	40	1,6	24	4,7	10,4
FBRP75A060HI	6,0	7/32	3,4	100	328	50	2,0	34	6,8	15,0
FBRP75A063HI	6,3	1/4	3,8	100	328	55	2,2	37	7,5	16,5
FBRP75A070HI	7,0	9/32	4,7	100	328	60	2,4	46	9,2	20,4
FBRP75A080HI	8,0	5/16	6,0	100	328	65	2,6	60	12,1	26,6
FBRP75A095HI	9,5	3/8	8,5	100	328	75	3,0	85	17,0	37,5
FBRP75A100HI	10,0	7/16	9,4	50	164	80	3,2	94	18,8	41,5
FBRP75A120HI	12,0	15/32	13,5	50	164	90	3,5	136	27,1	59,8
FBRP75A125HI	12,5	1/2	14,8	50	164	100	3,9	147	29,5	64,9
FBRP75A150HI	15,0	19/32	21,5	50	164	120	4,7	212	42,4	93,5

approx. 80° Shore A

Recommended pretension 4...8 %

approx. Coefficient of friction μ : Steel: 0,70 | PE: 0,40 | HDPE: 0,35

PU75A **plus** orange matt



Order No.	Diameter \varnothing		approx. weight kg/100m	Standard roll		Recommended min. pulley \varnothing		PT/DRIVE Fmax/belt Standard N	CONVEYANCE max. conveying weight Standard	
	mm	inch		m	ft	mm	inch		kg	lbs
FBRI0200G	2,0	5/64	0,5	200	656	10	0,4	4	0.8	1.7
FBRI0300G	3,0	1/8	0,9	200	656	20	0,8	9	1.8	3.9
FBRI0400G	4,0	5/32	1,6	200	656	30	1,2	16	3.2	7.0
FBRI0480G	4,8	3/16	2,2	200	656	35	1,4	23	4.6	10.1
FBRI0500G	5,0	1/5	2,4	100	328	40	1,6	25	4.9	10.9
FBRI0600G	6,0	7/32	3,4	100	328	50	2,0	36	7.1	15.7
FBRI0630G	6,3	1/4	3,8	100	328	55	2,2	39	7.9	17.3
FBRI0800G	8,0	5/16	6,0	100	328	65	2,6	63	12.7	27.9
FBRI0950G	9,5	3/8	8,5	100	328	75	3,0	89	17.9	39.4
FBRI1000G	10,0	7/16	9,4	50	164	80	3,2	99	19.8	43.6

approx. 80° Shore A

Recommended pretension 3...6 %

approx. Coefficient of friction μ : Steel: 0,70 | PE: 0,40 | HDPE: 0,35

PU80A transparent smooth



Order No.	Diameter \varnothing		approx. weight kg/100m	Standard roll		Recommended min. pulley \varnothing		PT/DRIVE Fmax/belt Standard N	CONVEYANCE max. conveying weight Standard	
	mm	inch		m	ft	mm	inch		kg	lbs
FBRP80A020TR	2,0	5/64	0,5	200	656	15	0,6	5	1,1	2,3
FBRP80A030TR	3,0	1/8	0,9	200	656	25	1,0	12	2,4	5,2
FBRP80A040TR	4,0	5/32	1,6	200	656	30	1,2	21	4,2	9,3
FBRP80A048TR	4,8	3/16	2,2	200	656	40	1,6	30	6,1	13,4
FBRP80A050TR	5,0	1/5	2,4	100	328	45	1,8	33	6,6	14,5
FBRP80A060TR	6,0	7/32	3,4	100	328	55	2,2	47	9,5	20,9
FBRP80A063TR	6,3	1/4	3,8	100	328	60	2,4	52	10,5	23,1
FBRP80A070TR	7,0	9/32	4,7	100	328	65	2,6	65	12,9	28,5
FBRP80A080TR	8,0	5/16	6,0	100	328	75	3,0	84	16,9	37,2
FBRP80A095TR	9,5	3/8	8,5	100	328	90	3,5	119	23,8	52,5
FBRP80A100TR	10,0	7/16	9,4	50	164	95	3,7	132	26,4	58,1
FBRP80A120TR	12,0	15/32	13,5	50	164	110	4,3	190	38,0	83,7
FBRP80A125TR	12,5	1/2	14,8	50	164	115	4,5	206	41,2	90,8
FBRP80A150TR	15,0	19/32	21,5	50	164	140	5,5	297	59,3	130,8
FBRP80A180TR	18,0	3/4	31,0	50	164	170	6,7	427	85,5	188,3
FBRP80A200TR	20,0	25/32	40,0	50	164	180	7,1	528	105,5	232,5

approx. 84° Shore A

Recommended pretension 4...8 %

approx. Coefficient of friction μ : Steel: 0,65 | PE: 0,35 | HDPE: 0,30

PU80A ultramarine blue smooth



Order No.	Diameter Ø		approx. weight kg/100m	Standard roll		Recommended min. pulley Ø		PT/DRIVE Fmax/belt Standard N	CONVEYANCE max. conveying weight Standard	
	mm	inch		m	ft	mm	inch		kg	lbs
FBRP80A020UB	2,0	5/64	0,5	200	656	15	0,6	5	1,0	2,1
FBRP80A030UB	3,0	1/8	0,9	200	656	25	1,0	11	2,1	4,7
FBRP80A040UB	4,0	5/32	1,6	200	656	30	1,2	19	3,8	8,4
FBRP80A048UB	4,8	3/16	2,2	200	656	40	1,6	27	5,5	12,1
FBRP80A050UB	5,0	1/5	2,4	100	328	45	1,8	30	6,0	13,1
FBRP80A060UB	6,0	7/32	3,4	100	328	55	2,2	43	8,6	18,9
FBRP80A063UB	6,3	1/4	3,8	100	328	60	2,4	47	9,5	20,9
FBRP80A070UB	7,0	9/32	4,7	100	328	65	2,6	58	11,7	25,8
FBRP80A080UB	8,0	5/16	6,0	100	328	75	3,0	76	15,3	33,7
FBRP80A095UB	9,5	3/8	8,5	100	328	90	3,6	108	21,5	47,5
FBRP80A100UB	10,0	7/16	9,4	50	164	95	3,8	119	23,9	52,6
FBRP80A120UB	12,0	15/32	13,5	50	164	110	4,4	172	34,4	75,7
FBRP80A125UB	12,5	1/2	14,8	50	164	115	4,6	186	37,3	82,2
FBRP80A150UB	15,0	19/32	21,5	50	164	140	5,5	268	53,7	118,3

approx. 84° Shore A

Recommended pretension 4...8 %

approx. Coefficient of friction μ : Steel: 0,65 | PE: 0,35 | HDPE: 0,30

PU80A ultramarine blue slightly rough



Order No.	Diameter Ø		approx. weight kg/100m	Standard roll		Recommended min. pulley Ø		PT/DRIVE Fmax/belt Standard N	CONVEYANCE max. conveying weight Standard	
	mm	inch		m	ft	mm	inch		kg	lbs
FBRP80A020BA	2,0	5/64	0,5	200	656	15	0,6	5	1,0	2,1
FBRP80A030BA	3,0	1/8	0,9	200	656	25	1,0	11	2,1	4,7
FBRP80A040BA	4,0	5/32	1,6	200	656	30	1,2	19	3,8	8,4
FBRP80A048BA	4,8	3/16	2,2	200	656	40	1,6	27	5,5	12,1
FBRP80A050BA	5,0	1/5	2,4	100	328	45	1,8	30	6,0	13,1
FBRP80A060BA	6,0	7/32	3,4	100	328	55	2,2	43	8,6	18,9
FBRP80A063BA	6,3	1/4	3,8	100	328	60	2,4	47	9,5	20,9
FBRP80A070BA	7,0	9/32	4,7	100	328	65	2,6	58	11,7	25,8
FBRP80A080BA	8,0	5/16	6,0	100	328	75	3,0	76	15,3	33,7
FBRP80A095BA	9,5	3/8	8,5	100	328	90	3,6	108	21,5	47,5
FBRP80A100BA	10,0	7/16	9,4	50	164	95	3,8	119	23,9	52,6
FBRP80A120BA	12,0	15/32	13,5	50	164	110	4,4	172	34,4	75,7
FBRP80A125BA	12,5	1/2	14,8	50	164	115	4,6	186	37,3	82,2
FBRP80A150BA	15,0	19/32	21,5	50	164	140	5,5	268	53,7	118,3

approx. 84° Shore A

Recommended pretension 4...8 %

approx. Coefficient of friction μ : Steel: 0,55 | PE: 0,30 | HDPE: 0,25

PU80A orange smooth



Order No.	Diameter Ø		approx. weight kg/100m	Standard roll		Recommended min. pulley Ø		PT/DRIVE Fmax/belt Standard N	CONVEYANCE max. conveying weight Standard	
	mm	inch		m	ft	mm	inch		kg	lbs
FBRP84A020	2,0	5/64	0,5	30	100	15	0,6	5	1,1	2,3
FBRP84A032	3,2	1/8	0,9	30	100	25	1,0	14	2,7	6,0
FBRP84A040	4,0	5/32	1,6	30	100	30	1,2	21	4,2	9,3
FBRP84A048	4,8	3/16	2,2	30	100	40	1,6	30	6,1	13,4
FBRP84A050	5,0	1/5	2,4	30	100	45	1,8	33	6,6	14,5
FBRP84A060	6,0	7/32	3,4	30	100	55	2,2	47	9,5	20,9
FBRP84A063	6,3	1/4	3,8	30	100	60	2,4	52	10,5	23,1
FBRP84A070	7,0	9/32	4,7	30	100	65	2,6	65	12,9	28,5
FBRP84A079	7,9	5/16	6,0	30	100	75	3,0	82	16,5	36,3
FBRP84A095	9,5	3/8	8,5	30	100	90	3,5	119	23,8	52,5
FBRP84A100	10,0	7/16	9,4	30	100	95	3,7	132	26,4	58,1
FBRP84A120	12,0	15/32	13,5	30	100	110	4,3	190	38,0	83,7
FBRP84A127	12,7	1/2	14,8	30	100	115	4,5	213	42,5	93,8
FBRP84A143	14,3	9/16	21,0	30	100	130	5,1	270	53,9	118,9
FBRP84A159	15,9	5/8	22,5	30	100	150	5,9	333	66,7	147,0
FBRP84A190	19,0	3/4	34,0	30	100	170	6,7	476	95,2	209,9

approx. 84° Shore A

Recommended pretension 4...8 %

approx. Coefficient of friction μ : Steel: 0,65 | PE: 0,35 | HDPE: 0,30

PU80A orange smooth, reinforced Polyester



Order No.	Diameter Ø		approx. weight kg/100m	Standard roll		Recommended min. pulley Ø		PT/DRIVE Fmax/belt Standard N	Overlap N	CONVEYANCE max. conveying weight			
	mm	inch		m	ft	mm	inch			Standard	Overlap	kg	lbs
FBRJ0600GA	6,0	7/32	3,4	30	100	55	2,2	47	197	9,5	20,9	39,3	86,6
FBRJ0630GA	6,3	1/4	3,8	30	100	60	2,4	52	198	10,5	23,1	39,7	87,4
FBRJ0700GA	7,0	9/32	4,7	30	100	65	2,6	65	203	12,9	28,5	40,6	89,5
FBRJ0800GA	8,0	5/16	6,0	30	100	80	3,2	84	210	16,9	37,2	42,1	92,7
FBRJ0950GA	9,5	3/8	8,5	30	100	90	3,6	119	223	23,8	52,5	44,7	98,5
FBRJ1000GA	10,0	7/16	9,4	30	100	100	4,0	132	228	26,4	58,1	45,6	100,6
FBRJ1200GA	12,0	15/32	13,5	30	100	110	4,4	190	607	38,0	83,7	121,4	267,6
FBRJ1250GA	12,5	1/2	14,8	30	100	115	4,6	206	613	41,2	90,8	122,6	270,3
FBRJ1430GA	14,3	9/16	21,0	30	100	130	5,2	270	886	53,9	118,9	177,1	390,4
FBRJ1900GA	19,0	3/4	34,0	30	100	170	6,8	476	963	95,2	209,9	192,6	424,5

approx. 84° Shore A

Max. pretension

Standard 2 %

Overlap 3 %

approx. Coefficient of friction μ : Steel: 0,65 | PE: 0,35 | HDPE: 0,30

For overlap splices, the recommended minimum pulley diameter must be increased by +30%.

PU80A **safe** capri blue smooth

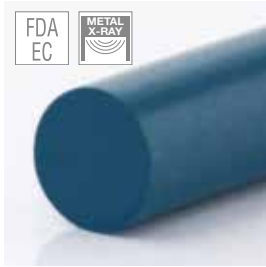

Metal and X-ray detectable belt

Order No.	Diameter \varnothing		approx. weight kg/100m	Standard roll		Recommended min. pulley \varnothing		PT/DRIVE Fmax/belt Standard N	CONVEYANCE max. conveying weight Standard	
	mm	inch		m	ft	mm	inch		kg	lbs
FBRJ020LGM	2,0	5/64	0,5	200	656	15	0,6	4	0,8	1,7
FBRJ030LGM	3,0	1/8	0,9	200	656	25	1,0	9	1,8	3,9
FBRJ032LGM	3,2	1/8	0,9	30	100	25	1,0	10	2,0	4,5
FBRJ040LGM	4,0	5/32	1,6	200	656	30	1,2	16	3,2	7,0
FBRJ048LGM	4,8	3/16	2,2	30	100	40	1,6	23	4,6	10,0
FBRJ050LGM	5,0	1/5	2,4	100	328	45	1,8	25	4,9	10,9
FBRJ060LGM	6,0	7/32	3,4	100	328	55	2,2	36	7,1	15,7
FBRJ063LGM	6,3	1/4	3,8	30	100	60	2,4	39	7,9	17,3
FBRJ080LGM	8,0	5/16	6,0	100	328	75	3,0	63	12,7	27,9
FBRJ095LGM	9,5	3/8	8,5	30	100	90	3,5	89	17,9	39,3
FBRJ100LGM	10,0	7/16	9,4	50	164	95	3,7	99	19,8	43,6
FBRJ120LGM	12,0	15/32	13,5	50	164	110	4,3	142	28,5	62,8
FBRJ125LGM	12,5	1/2	14,8	30	100	115	4,5	155	30,9	68,1
FBRJ143LGM	14,3	9/16	21,0	30	100	130	5,1	202	40,5	89,2
FBRJ150LGM	15,0	19/32	21,5	50	164	140	5,5	223	44,5	98,1

approx. 84° Shore A

Recommended pretension 3...6 %

approx. Coefficient of friction μ : Steel: 0,65 | PE: 0,35 | HDPE: 0,30

PU85A green smooth



Order No.	Diameter \varnothing		approx. weight kg/100m	Standard roll		Recommended min. pulley \varnothing		PT/DRIVE Fmax/belt Standard N	CONVEYANCE max. conveying weight Standard	
	mm	inch		m	ft	mm	inch		kg	lbs
FBRP85A020	2,0	5/64	0,5	200	656	15	0,6	6	1,3	2,8
FBRP85A030	3,0	1/8	0,9	200	656	25	1,0	14	2,8	6,2
FBRP85A040	4,0	5/32	1,6	200	656	35	1,4	25	5,0	11,1
FBRP85A048	4,8	3/16	2,2	200	656	45	1,8	36	7,2	16,0
FBRP85A050	5,0	1/5	2,4	100	328	50	2,0	39	7,9	17,3
FBRP85A060	6,0	7/32	3,4	100	328	60	2,4	57	11,3	24,9
FBRP85A063	6,3	1/4	3,8	100	328	65	2,6	62	12,5	27,5
FBRP85A070	7,0	9/32	4,7	100	328	70	2,8	77	15,4	33,9
FBRP85A080	8,0	5/16	6,0	100	328	80	3,2	101	20,1	44,3
FBRP85A095	9,5	3/8	8,5	100	328	95	3,8	142	28,4	62,5
FBRP85A100	10,0	7/16	9,4	50	164	100	4,0	157	31,4	69,2
FBRP85A120	12,0	15/32	13,5	50	164	120	4,8	226	45,2	99,7
FBRP85A125	12,5	1/2	14,8	50	164	125	5,0	245	49,1	108,2
FBRP85A15	15,0	19/32	21,5	50	164	150	6,0	353	70,7	155,8
FBRP85A18	18,0	3/4	31,0	50	164	180	7,2	509	101,8	224,3
FBRP85A20	20,0	25/32	40,0	50	164	200	7,9	628	125,7	277,0

approx. 88° Shore A

Recommended pretension 4...8 %

approx. Coefficient of friction μ : Steel: 0,60 | PE: 0,35 | HDPE: 0,30

PU85A green rough



Order No.	Diameter \varnothing		approx. weight kg/100m	Standard roll		Recommended min. pulley \varnothing		PT/DRIVE Fmax/belt Standard N	CONVEYANCE max. conveying weight Standard	
	mm	inch		m	ft	mm	inch		kg	lbs
FBRP85A020R	2,0	5/64	0,5	200	656	15	0,6	6	1,3	2,8
FBRP85A030R	3,0	1/8	0,9	200	656	25	1,0	14	2,8	6,2
FBRP85A040R	4,0	5/32	1,6	200	656	35	1,4	25	5,0	11,1
FBRP85A048R	4,8	3/16	2,2	200	656	45	1,8	36	7,2	16,0
FBRP85A050R	5,0	1/5	2,4	100	328	50	2,0	39	7,9	17,3
FBRP85A060R	6,0	7/32	3,4	100	328	60	2,4	57	11,3	24,9
FBRP85A063R	6,3	1/4	3,8	100	328	65	2,6	62	12,5	27,5
FBRP85A070R	7,0	9/32	4,7	100	328	70	2,8	77	15,4	33,9
FBRP85A080R	8,0	5/16	6,0	100	328	80	3,2	101	20,1	44,3
FBRP85A095R	9,5	3/8	8,5	100	328	95	3,8	142	28,4	62,5
FBRP85A100R	10,0	7/16	9,4	50	164	100	4,0	157	31,4	69,2
FBRP85A120R	12,0	15/32	13,5	50	164	120	4,8	226	45,2	99,7
FBRP85A125R	12,5	1/2	14,8	50	164	125	5,0	245	49,1	108,2
FBRP85A15R	15,0	19/32	21,5	50	164	150	6,0	353	70,7	155,8
FBRP85A18R	18,0	3/4	31,0	50	164	180	7,2	509	101,8	224,3
FBRP85A20R	20,0	25/32	40,0	50	164	200	7,9	628	125,7	277,0

approx. 88° Shore A

Recommended pretension 4...8 %

approx. Coefficient of friction μ : Steel: 0,45 | PE: 0,30 | HDPE: 0,25

PU85A green smooth, reinforced Aramid



Order No.	Diameter \varnothing		approx. weight kg/100m	Standard roll		Recommended min. pulley \varnothing		PT/DRIVE Fmax/belt Standard N	Overlap N	CONVEYANCE max. conveying weight			
	mm	inch		m	ft	mm	inch			Standard kg	Standard lbs	Overlap kg	Overlap lbs
FBZRP85A050A	5,0	1/5	2,4	100	328	50	2,0	39	–	7,9	17,3	–	–
FBZRP85A060A	6,0	7/32	3,4	100	328	60	2,3	57	176	11,3	24,9	35,2	77,7
FBZRP85A063A	6,3	1/4	3,8	100	328	65	2,5	62	177	12,5	27,5	35,5	78,1
FBZRP85A070A	7,0	9/32	4,7	100	328	70	2,8	77	180	15,4	33,9	36,0	79,4
FBZRP85A080A	8,0	5/16	6,0	100	328	80	3,2	101	293	20,1	44,3	58,7	129,3
FBZRP85A095A	9,5	3/8	8,5	100	328	95	3,7	142	301	28,4	62,5	60,2	132,7
FBZRP85A100A	10,0	7/16	9,4	50	164	100	3,9	157	304	31,4	69,2	60,8	134,0
FBZRP85A120A	12,0	15/32	13,5	50	164	120	4,7	226	317	45,2	99,7	63,4	139,7
FBZRP85A125A	12,5	1/2	14,8	50	164	125	4,9	245	321	49,1	108,2	64,1	141,3
FBZRP85A143A	14,3	9/16	19,3	50	164	145	5,7	1862	625	372,5	820,9	125,1	275,6
FBZRP85A150A	15,0	19/32	21,5	50	164	150	5,9	353	626	70,7	155,8	125,2	276,0
FBZRP85A180A	18,0	3/4	31,0	50	164	190	7,5	509	655	101,8	224,3	131,0	288,8
FBZRP85A200A	20,0	25/32	40,0	50	164	200	7,9	628	678	125,7	277,0	135,5	298,7

approx. 88° Shore A

Max. pretension

Standard 1,5 %

Overlap 1,5 %

approx. Coefficient of friction μ : Steel: 0,60 | PE: 0,35 | HDPE: 0,30

For overlap splices, the recommended minimum pulley diameter must be increased by +30%.

PU85A green rough, reinforced Aramid



Order No.	Diameter Ø		approx. weight kg/100m	Standard roll		Recommended min. pulley Ø		PT/DRIVE Fmax/belt Standard N	Overlap N	CONVEYANCE max. conveying weight			
	mm	inch		m	ft	mm	inch			Standard		Overlap	
										kg	lbs	kg	lbs
FBZR85A050RA	5,0	1/5	2,4	100	328	50	2,0	39	–	7,9	17,3	–	–
FBZR85A060RA	6,0	7/32	3,4	100	328	60	2,3	57	176	11,3	24,9	35,2	77,7
FBZR85A063RA	6,3	1/4	3,8	100	328	65	2,5	62	177	12,5	27,5	35,5	78,1
FBZR85A070RA	7,0	9/32	4,7	100	328	70	2,8	77	180	15,4	33,9	36,0	79,4
FBZR85A080RA	8,0	5/16	6,0	100	328	80	3,2	101	293	20,1	44,3	58,7	129,3
FBZR85A095RA	9,5	3/8	8,5	100	328	95	3,7	142	301	28,4	62,5	60,2	132,7
FBZR85A100RA	10,0	7/16	9,4	50	164	100	3,9	157	304	31,4	69,2	60,8	134,0
FBZR85A120RA	12,0	15/32	13,5	50	164	120	4,7	226	317	45,2	99,7	63,4	139,7
FBZR85A127RA	12,5	1/2	14,8	50	164	125	4,9	245	321	49,1	108,2	64,1	141,3
FBZR85A143RA	14,3	9/16	19,3	50	164	145	5,7	1862	625	372,5	820,9	125,1	275,6
FBZR85A150RA	15,0	19/32	21,5	50	164	150	5,9	353	626	70,7	155,8	125,2	276,0
FBZR85A180RA	18,0	3/4	31,0	50	164	190	7,5	509	655	101,8	224,3	131,0	288,8
FBZR85A200RA	20,0	25/32	40,0	50	164	200	7,9	628	678	125,7	277,0	135,5	298,7

approx. 88° Shore A

Max. pretension

Standard 1,5 %

Overlap 1,5 %

approx. Coefficient of friction μ : Steel: 0,45 | PE: 0,30 | HDPE: 0,25

For overlap splices, the recommended minimum pulley diameter must be increased by +30%.

PU85A ultramarine blue rough



Order No.	Diameter Ø		approx. weight kg/100m	Standard roll		Recommended min. pulley Ø		PT/DRIVE Fmax/belt Standard N	CONVEYANCE max. conveying weight	
	mm	inch		m	ft	mm	inch		Standard	
									kg	lbs
FBRK020LRB	2,0	5/64	0,5	200	656	15	0,6	6	1,3	2,8
FBRK030LRB	3,0	1/8	0,9	200	656	25	1,0	14	2,8	6,2
FBRK040LRB	4,0	5/32	1,6	200	656	35	1,4	25	5,0	11,1
FBRK048LRB	4,8	3/16	2,2	200	656	45	1,8	36	7,2	16,0
FBRK050LRB	5,0	1/5	2,4	100	328	50	2,0	39	7,9	17,3
FBRK060LRB	6,0	7/32	3,4	100	328	60	2,4	57	11,3	24,9
FBRK063LRB	6,3	1/4	3,8	100	328	65	2,6	62	12,5	27,5
FBRK070LRB	7,0	9/32	4,7	100	328	70	2,8	77	15,4	33,9
FBRK080LRB	8,0	5/16	6,0	100	328	80	3,2	101	20,1	44,3
FBRK095LRB	9,5	3/8	8,5	100	328	95	3,8	142	28,4	62,5
FBRK100LRB	10,0	7/16	9,4	50	164	100	4,0	157	31,4	69,2
FBRK120LRB	12,0	15/32	13,5	50	164	120	4,8	226	45,2	99,7
FBRK125LRB	12,5	1/2	14,8	50	164	125	5,0	245	49,1	108,2
FBRK150LRB	15,0	19/32	21,5	50	164	150	6,0	353	70,7	155,8

approx. 88° Shore A

Recommended pretension 4...8 %

approx. Coefficient of friction μ : Steel: 0,45 | PE: 0,30 | HDPE: 0,25

PU85A ultramarine blue rough, reinforced Aramid



Order No.	Diameter Ø		approx. weight kg/100m	Standard roll		Recommended min. pulley Ø		PT/DRIVE Fmax/belt Standard N	Overlap N	CONVEYANCE max. conveying weight			
	mm	inch		m	ft	mm	inch			Standard kg	Standard lbs	Overlap kg	Overlap lbs
FBRK050LRC	5,0	1/5	2,4	100	328	50	2,0	39	173	7,9	17,3	34,6	76,2
FBRK060LRC	6,0	7/32	3,4	100	328	60	2,3	57	176	11,3	24,9	35,2	77,7
FBRK063LRC	6,3	1/4	3,8	100	328	65	2,5	62	177	12,5	27,5	35,5	78,1
FBRK080LRC	8,0	5/16	6,0	100	328	80	3,2	101	293	20,1	44,3	58,7	129,3
FBRK095LRC	9,5	3/8	8,5	100	328	95	3,7	142	301	28,4	62,5	60,2	132,7
FBRK100LRC	10,0	7/16	9,4	50	164	100	3,9	157	304	31,4	69,2	60,8	134,0
FBRK120LRC	12,0	15/32	13,5	50	164	120	4,7	226	317	45,2	99,7	63,4	139,7
FBRK125LRC	12,5	1/2	14,8	50	164	125	4,9	245	321	49,1	108,2	64,1	141,3
FBRK150LRC	15,0	19/32	21,5	50	164	150	5,9	353	626	70,7	155,8	125,2	276,0

approx. 88° Shore A

Max. pretension

Standard 1,5 %

Overlap 1,5 %

approx. Coefficient of friction μ : Steel: 0,45 | PE: 0,30 | HDPE: 0,25

For overlap splices, the recommended minimum pulley diameter must be increased by +30%.

PU85A sapphire blue smooth

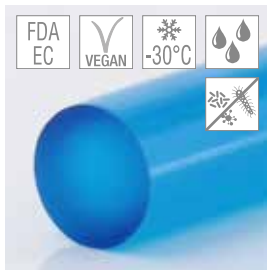

Order No.	Diameter Ø		approx. weight kg/100m	Standard roll		Recommended min. pulley Ø		PT/DRIVE Fmax/belt Standard N	CONVEYANCE max. conveying weight Standard	
	mm	inch		m	ft	mm	inch		kg	lbs
FBRK020LGAAA	2,0	5/64	0,5	200	656	15	0,6	6	1,2	2,5
FBRK030LGAAA	3,0	1/8	0,9	200	656	25	1,0	13	2,6	5,7
FBRK040LGAAA	4,0	5/32	1,6	200	656	35	1,4	23	4,6	10,2
FBRK048LGAAA	4,8	3/16	2,2	200	656	45	1,8	33	6,7	14,7
FBRK050LGAAA	5,0	1/5	2,4	100	328	50	2,0	36	7,2	15,9
FBRK060LGAAA	6,0	7/32	3,4	100	328	60	2,4	52	10,4	22,9
FBRK063LGAAA	6,3	1/4	3,8	100	328	65	2,6	57	11,5	25,3
FBRK070LGAAA	7,0	9/32	4,7	100	328	70	2,8	71	14,2	31,2
FBRK080LGAAA	8,0	5/16	6,0	100	328	80	3,2	92	18,5	40,8
FBRK095LGAAA	9,5	3/8	8,5	100	328	95	3,8	130	26,1	57,5
FBRK100LGAAA	10,0	7/16	9,4	50	164	100	4,0	145	28,9	63,7
FBRK120LGAAA	12,0	15/32	13,5	50	164	120	4,8	208	41,6	91,7
FBRK125LGAAA	12,5	1/2	14,8	50	164	125	5,0	226	45,2	99,5
FBRK150LGAAA	15,0	19/32	21,5	50	164	150	6,0	325	65,0	143,3

approx. 88° Shore A

Recommended pretension 4...8 %

approx. Coefficient of friction μ : Steel: 0,60 | PE: 0,35 | HDPE: 0,30

PU85A sapphire blue smooth, reinforced Polyester



Order No.	Diameter Ø		approx. weight kg/100m	Standard roll		Recommended min. pulley Ø		PT/DRIVE Fmax/belt		CONVEYANCE max. conveying weight			
	mm	inch		m	ft	mm	inch	Standard N	Overlap N	Standard		Overlap	
										kg	lbs	kg	lbs
FBRK060LGAAC	6,0	7/32	3,4	100	328	60	2,4	52	198	10,4	22,9	39,7	87,4
FBRK063LGA	6,3	1/4	3,8	100	328	65	2,6	57	200	11,5	25,3	40,1	88,3
FBRK070LGA	7,0	9/32	4,7	100	328	70	2,8	71	205	14,2	31,2	41,1	90,5
FBRK080LGA	8,0	5/16	6,0	100	328	80	3,2	92	213	18,5	40,8	42,7	94,1
FBRK095LGA	9,5	3/8	8,5	100	328	95	3,7	130	228	26,1	57,5	45,5	100,4
FBRK100LGA	10,0	7/16	9,4	50	164	100	3,9	145	233	28,9	63,7	46,6	102,7
FBRK120LGA	12,0	15/32	13,5	50	164	120	4,7	208	614	41,6	91,7	122,8	270,6
FBRK125LGA	12,5	1/2	14,8	50	164	125	4,9	226	621	45,2	99,5	124,1	273,6
FBRK150LGA	15,0	19/32	21,5	50	164	150	5,9	325	906	65,0	143,3	181,3	399,6

approx. 88° Shore A	
Max. pretension	
Standard	2 %
Overlap	3 %

approx. Coefficient of friction μ : Steel: 0,60 | PE: 0,35 | HDPE: 0,30

For overlap splices, the recommended minimum pulley diameter must be increased by +30%.

PU85A plus ultramarine blue rough



Order No.	Diameter Ø		approx. weight kg/100m	Standard roll		Recommended min. pulley Ø		PT/DRIVE Fmax/belt Standard N	CONVEYANCE max. conveying weight Standard	
	mm	inch		m	ft	mm	inch		kg	lbs
FBRK020LR	2,0	5/64	0,5	200	656	15	0,6	6	1,2	2,7
FBRK030LR	3,0	1/8	0,9	200	656	25	1,0	14	2,7	6,0
FBRK040LR	4,0	5/32	1,6	200	656	35	1,4	24	4,8	10,6
FBRK048LR	4,8	3/16	2,2	200	656	45	1,8	35	6,9	15,3
FBRK050LR	5,0	1/5	2,4	100	328	50	2,0	38	7,5	16,6
FBRK060LR	6,0	7/32	3,4	100	328	60	2,4	54	10,9	23,9
FBRK063LR	6,3	1/4	3,8	100	328	65	2,6	60	12,0	26,4
FBRK070LR	7,0	9/32	4,7	100	328	70	2,8	74	14,8	32,6
FBRK080LR	8,0	5/16	6,0	100	328	80	3,2	97	19,3	42,5
FBRK095LR	9,5	3/8	8,5	100	328	95	3,8	136	27,2	60,0
FBRK100LR	10,0	7/16	9,4	50	164	100	4,0	151	30,2	66,5
FBRK120LR	12,0	15/32	13,5	50	164	120	4,7	217	43,4	95,7
FBRK125LR	12,5	1/2	14,8	50	164	125	4,9	236	47,1	103,9
FBRK150LR	15,0	19/32	21,5	50	164	150	5,9	339	67,9	149,6

approx. 88° Shore A	
Recommended pretension	3...6 %

approx. Coefficient of friction μ : Steel: 0,45 | PE: 0,30 | HDPE: 0,25

PU85A ultramarine blue smooth, reinforced glass fibre PU



Order No.	Diameter Ø		approx. weight kg/100m	Standard roll		Recommended min. pulley Ø		PT/DRIVE Fmax/belt Standard N	CONVEYANCE max. conveying weight Standard	
	mm	inch		m	ft	mm	inch		kg	lbs
FBZRP85A080	8,0	5/16	6,0	100	328	85	3,4	93	18,6	41,0
FBZRP85A095	9,5	3/8	8,5	100	328	100	4,0	103	20,7	45,6
FBZRP85A100	10,0	7/16	9,4	50	164	105	4,2	107	21,5	47,3
FBZRP85A120	12,0	15/32	13,5	50	164	125	5,0	176	35,3	77,8
FBZRP85A125	12,5	1/2	14,8	50	164	130	5,2	182	36,3	80,1
FBZRP85A143	14,3	9/16	21,0	50	164	150	6,0	202	40,5	89,2
FBZRP85A150	15,0	19/32	21,5	50	164	155	6,2	209	41,7	91,9

approx. 88° Shore A	
Recommended pretension	0,5...2 %

approx. Coefficient of friction μ : Steel: 0,60 | PE: 0,35 | HDPE: 0,30

PU85A ultramarine blue rough, reinforced glass fibre PU



Order No.	Diameter \varnothing		approx. weight kg/100m	Standard roll		Recommended min. pulley \varnothing		PT/DRIVE Fmax/belt Standard N	CONVEYANCE max. conveying weight Standard	
	mm	inch		m	ft	mm	inch		kg	lbs
FBZRP85A080R	8,0	5/16	6,0	100	328	85	3,2	93	18,6	41,0
FBZRP85A095R	9,5	3/8	8,5	100	328	100	3,7	103	20,7	45,6
FBZRP85A100R	10,0	7/16	9,4	50	164	105	3,9	107	21,5	47,3
FBZRP85A120R	12,0	15/32	13,5	50	164	125	4,7	176	35,3	77,8
FBZRP85A125R	12,5	1/2	14,8	50	164	130	4,9	182	36,3	80,1
FBZRP85A143R	14,3	9/16	21,0	50	164	150	5,7	202	40,5	89,2
FBZRP85A150R	15,0	19/32	21,5	50	164	155	5,9	209	41,7	91,9
FBZRP85A180R	18,0	3/4	31,0	50	164	195	7,5	249	49,9	109,9

approx. 88° Shore A

Recommended pretension 0,5...2 %

approx. Coefficient of friction μ : Steel: 0,45 | PE: 0,30 | HDPE: 0,25

PU85A emerald green smooth, antistatic-dissipative



Belt for electrostatic discharge.

Order No.	Diameter \varnothing		approx. weight kg/100m	Standard roll		Recommended min. pulley \varnothing		PT/DRIVE Fmax/belt Standard N	CONVEYANCE max. conveying weight Standard	
	mm	inch		m	ft	mm	inch		kg	lbs
FBRK020GGAAA	2,0	5/64	0,5	200	656	15	0,6	6	1,2	2,5
FBRK030GGAAA	3,0	1/8	0,9	200	656	25	1,0	13	2,6	5,7
FBRK040GGAAA	4,0	5/32	1,6	200	656	35	1,4	23	4,6	10,2
FBRK048GGAAA	4,8	3/16	2,2	200	656	45	1,8	33	6,7	14,7
FBRK050GGAAA	5,0	1/5	2,4	100	328	50	2,0	36	7,2	15,9
FBRK060GGAAA	6,0	7/32	3,4	100	328	60	2,4	52	10,4	22,9
FBRK063GGAAA	6,3	1/4	3,8	100	328	65	2,6	57	11,5	25,3
FBRK080GGAAA	8,0	5/16	6,0	100	328	80	3,2	92	18,5	40,8
FBRK095GGAAA	9,5	3/8	8,5	100	328	95	3,8	130	26,1	57,5
FBRK100GGAAA	10,0	7/16	9,4	50	164	100	4,0	145	28,9	63,7
FBRK120GGAAA	12,0	15/32	13,5	50	164	120	4,8	208	41,6	91,7

approx. 88° Shore A

Recommended pretension 4...8 %

$R_g = <10^9 \Omega (1 G\Omega)$

Surface resistance to earth according to IEC61340-2-3/EN61340-5-1

approx. Coefficient of friction μ : Steel: 0,60 | PE: 0,35 | HDPE: 0,30

PU85A black smooth, antistatic conductive



Order No.	Diameter \varnothing		approx. weight kg/100m	Standard roll		Recommended min. pulley \varnothing		PT/DRIVE Fmax/belt Standard N	CONVEYANCE max. conveying weight Standard	
	mm	inch		m	ft	mm	inch		kg	lbs
FBRK020SGA	2,0	5/64	0,4	200	656	20	0,8	5,8	1,2	2,7
FBRK030SGA	3,0	1/8	0,9	200	656	30	1,2	13	2,5	5,6
FBRK040SGA	4,0	5/32	1,6	200	656	40	1,6	23	4,5	10,0
FBRK050SGA	5,0	1/5	2,4	100	328	50	2,0	35	7,1	15,6
FBRK060SGA	6,0	7/32	3,4	100	328	60	2,4	51	10,2	22,4

approx. 88° Shore A

Recommended pretension 3...6 %

approx. Coefficient of friction μ : Steel: 0,40 | PE: 0,25 | HDPE: 0,20

Belt for electrostatic discharge, $R_g = 10^6 \Omega (1 M\Omega)$, Surface resistance to earth according to IEC61340-2-3/EN61340-5-1

PU90A white smooth



● Red on request

Order No.	Diameter Ø		approx. weight kg/100m	Standard roll		Recommended min. pulley Ø		PT/DRIVE Fmax/belt Standard N	CONVEYANCE max. conveying weight Standard	
	mm	inch		m	ft	mm	inch		kg	lbs
FBRP90A020	2,0	5/64	0,5	200	656	20	0,8	7	1,4	3,2
FBRP90A030	3,0	1/8	0,9	200	656	30	1,2	16	3,3	7,2
FBRP90A040	4,0	5/32	1,6	200	656	40	1,6	29	5,8	12,7
FBRP90A048	4,8	3/16	2,2	200	656	50	2,0	42	8,3	18,3
FBRP90A050	5,0	1/5	2,4	100	328	55	2,2	45	9,0	19,9
FBRP90A060	6,0	7/32	3,4	100	328	70	2,8	65	13,0	28,7
FBRP90A063	6,3	1/4	3,8	100	328	75	3,0	72	14,3	31,6
FBRP90A080	8,0	5/16	6,0	100	328	90	3,6	116	23,1	51,0
FBRP90A095	9,5	3/8	8,5	100	328	105	4,2	163	32,6	71,9
FBRP90A100	10,0	7/16	9,4	50	164	110	4,4	181	36,1	79,6
FBRP90A120	12,0	15/32	13,5	50	164	130	5,1	260	52,0	114,7
FBRP90A125	12,5	1/2	14,8	50	164	135	5,3	282	56,5	124,4
FBRP90A15	15,0	19/32	21,5	50	164	165	6,5	406	81,3	179,2
FBRP90A18	18,0	3/4	31,0	50	164	200	7,9	585	117,1	258,0
FBRP90A20	20,0	25/32	40,0	50	164	220	8,7	723	144,5	318,5

approx. 92° Shore A

Recommended pretension 3...5 %

approx. Coefficient of friction μ : Steel: 0,50 | PE: 0,30 | HDPE: 0,25

PU90A white smooth, reinforced Polyester



Order No.	Diameter Ø		approx. weight kg/100m	Standard roll		Recommended min. pulley Ø		PT/DRIVE Fmax/belt Standard		CONVEYANCE max. conveying weight			
	mm	inch		m	ft	mm	inch	N	Overlap N	Standard		Overlap	
										kg	lbs	kg	lbs
FBZRP90A060P	6,0	7/32	3,4	100	328	70	2,8	65	172	13,0	28,7	34,3	75,6
FBZRP90A063P	6,3	1/4	3,8	100	328	75	3,0	72	176	14,3	31,6	35,1	77,4
FBZRP90A070P	7,0	9/32	4,7	100	328	85	3,3	89	232	17,7	39,0	46,4	102,2
FBZRP90A080P	8,0	5/16	6,0	100	328	90	3,6	116	248	23,1	51,0	49,6	109,4
FBZRP90A095P	9,5	3/8	8,5	100	328	105	4,2	163	277	32,6	71,9	55,3	121,9
FBZRP90A100P	10,0	7/16	9,4	50	164	110	4,4	181	287	36,1	79,6	57,4	126,6
FBZRP90A120P	12,0	15/32	13,5	50	164	130	5,1	260	692	52,0	114,7	138,4	305,0
FBZRP90A125P	12,5	1/2	14,8	50	164	135	5,3	282	705	56,5	124,4	141,1	310,9
FBZRP90A150P	15,0	19/32	21,5	50	164	165	6,5	406	1028	81,3	179,2	205,7	453,3
FBZRP90A180P	18,0	3/4	31,0	50	164	200	7,9	585	1136	117,1	258,0	227,1	500,6
FBZRP90A200P	20,0	25/32	40,0	50	164	220	8,7	723	1218	144,5	318,5	243,6	536,9

approx. 92° Shore A

Max. pretension

Standard 2 %

Overlap 3 %

approx. Coefficient of friction μ : Steel: 0,50 | PE: 0,30 | HDPE: 0,25

For overlap splices, the recommended minimum pulley diameter must be increased by +30%.

TPE40D beige smooth



TPE40D beige smooth with reinforcement on request

Order No.	Diameter \varnothing		approx. weight kg/100m	Standard roll		Recommended min. pulley \varnothing		PT/DRIVE Fmax/belt Standard N	CONVEYANCE max. conveying weight Standard	
	mm	inch		m	ft	mm	inch		kg	lbs
FBRK040D030	3,0	1/8	0,9	200	656	30	1,2	16	3,3	7,2
FBRK040D040	4,0	5/32	1,6	200	656	40	1,6	29	5,8	12,9
FBRK040D048	4,8	3/16	2,2	200	656	50	2,0	42	8,4	18,5
FBRK040D050	5,0	1/5	2,4	100	328	55	2,2	46	9,1	20,1
FBRK040D060	6,0	7/32	3,4	100	328	70	2,8	66	13,1	28,9
FBRK040D063	6,3	1/4	3,8	100	328	75	3,0	72	14,5	31,9
FBRK040D070	7,0	9/32	4,7	100	328	85	3,3	89	17,9	39,4
FBRK040D080	8,0	5/16	6,0	100	328	90	3,6	117	23,3	51,4
FBRK040D095	9,5	3/8	8,5	100	328	105	4,2	164	32,9	72,5
FBRK040D100	10,0	7/16	9,4	50	164	110	4,4	182	36,4	80,3
FBRK040D120	12,0	15/32	13,5	50	164	130	5,1	262	52,5	115,7
FBRK040D125	12,5	1/2	14,8	50	164	135	5,3	285	56,9	125,5
FBRK040D150	15,0	19/32	21,5	50	164	165	6,5	410	82,0	180,7

approx. 40° Shore D / 95° Shore A

Recommended pretension 2...4 %

approx. Coefficient of friction μ : Steel: 0,50 | PE: 0,30 | HDPE: 0,25

TPE55D beige smooth



Further colors on request

Order No.	Diameter \varnothing		approx. weight kg/100m	Standard roll		Recommended min. pulley \varnothing		PT/DRIVE Fmax/belt Standard N	CONVEYANCE max. conveying weight Standard	
	mm	inch		m	ft	mm	inch		kg	lbs
FBRH55D030B	3,0	1/8	0,9	200	656	40	1,6	34	6,8	15,0
FBRH55D040B	4,0	5/32	1,6	200	656	50	2,0	60	12,1	26,6
FBRH55D048B	4,8	3/16	2,2	200	656	60	2,4	87	17,4	38,3
FBRH55D050B	5,0	1/5	2,4	100	328	65	2,6	94	18,8	41,5
FBRH55D060B	6,0	7/32	3,4	100	328	80	3,2	136	27,1	59,8
FBRH55D063B	6,3	1/4	3,8	100	328	85	3,3	150	29,9	66,0
FBRH55D080B	8,0	5/16	6,0	100	328	110	4,3	241	48,3	106,4
FBRH55D095B	9,5	3/8	8,5	100	328	135	5,3	340	68,0	150,0
FBRH55D100B	10,0	7/16	9,4	50	164	145	5,7	377	75,4	166,2
FBRH55D120B	12,0	15/32	13,5	50	164	170	6,7	543	108,6	239,3
FBRH55D125B	12,5	1/2	14,8	50	164	180	7,1	589	117,8	259,7
FBRH55D150B	15,0	19/32	21,5	50	164	210	8,3	848	169,6	373,9
FBRH55D180B	18,0	3/4	31,0	50	164	250	9,8	1221	244,3	538,4

approx. 55° Shore D / 100° Shore A

Recommended pretension 2...4 %

approx. Coefficient of friction μ : Steel: 0,35 | PE: 0,20 | HDPE: 0,15

TPE55D beige smooth, reinforced Polyester



55° Shore D - approx. 100° Shore A	
Max. pretension	
Standard	2 %
Overlap	3 %

For overlap splices, the recommended minimum pulley diameter must be increased by +30%.

Order No.	Diameter Ø		approx. weight kg/100m	Standard roll		Recommended min. pulley Ø		PT/DRIVE Fmax/belt		CONVEYANCE max. conveying weight			
	mm	inch		m	ft	mm	inch	Standard N	Overlap N	Standard		Overlap	
										kg	lbs	kg	lbs
FBZRH55D060B	6,0	7/32	3,4	100	328	80	3,2	136	281	27,1	59,8	56,1	123,7
FBZRH55D063B	6,3	1/4	3,8	100	328	85	3,3	150	291	29,9	66,0	58,2	128,3
FBZRH55D070B	7,0	9/32	4,7	100	328	95	3,7	185	317	36,9	81,4	63,5	139,9
FBZRH55D080B	8,0	5/16	6,0	100	328	110	4,3	241	360	48,3	106,4	71,9	158,6
FBZRH55D095B	9,5	3/8	8,5	100	328	135	5,3	340	434	68,0	150,0	86,8	191,3
FBZRH55D100B	10,0	7/16	9,4	50	164	145	5,7	377	461	75,4	166,2	92,3	203,4
FBZRH55D120B	12,0	15/32	13,5	50	164	170	6,7	543	943	108,6	239,3	188,6	415,7
FBZRH55D125B	12,5	1/2	14,8	50	164	180	7,1	589	978	117,8	259,7	195,5	431,0
FBZRH55D150B	15,0	19/32	21,5	50	164	210	8,3	848	1421	169,6	373,9	284,1	626,2
FBZRH55D180B	18,0	3/4	31,0	50	164	250	9,8	1221	1701	244,3	538,4	340,1	749,6

approx. Coefficient of friction μ : Steel: 0,35 | PE: 0,20 | HDPE: 0,15



Hollow round belts with brass connector

Hollow round belts generally offer two advantages:

- The flexibility of the belts allows them to be used with small pulley diameters.
- In case of belt breakage, downtime can be minimised by using a nipple connection (see page 96). However, hollow round belts should always be welded.



PU75A red smooth



approx. 80° Shore A

Recommended pretension 4...8 %

Order No.	Diameter Ø Outer		approx. weight kg/100m	Standard roll		Recommended min. pulley Ø		PT/DRIVE Fmax/belt Standard N	CONVEYANCE max. conveying weight, Standard		Suitable nipple type Order No.
	mm	inch		m	ft	mm	inch		kg	lbs	
FBHP75A048	4,8	3/16	1,8	200	656	30	1,2	21	4,2	9,3	FBN048
FBHP75A063	6,3	1/4	3,2	100	328	45	1,8	36	7,1	15,7	FBN063
FBHP75A080	8,0	5/16	5,1	100	328	55	2,2	57	11,5	25,3	FBN080N
FBHP75A095	9,5	3/8	7,2	100	328	65	2,6	81	16,2	35,7	FBN095
FBHP75A125	12,5	1/2	12,4	50	164	85	3,4	138	27,6	60,8	FBN125-150
FBHP75A150	15,0	19/32	19,0	50	164	100	4,0	211	42,3	93,2	FBN125-150

approx. Coefficient of friction μ : Steel: 0,70 | PE: 0,40 | HDPE: 0,35

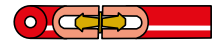

PU75A sky blue smooth



approx. 80° Shore A

Recommended pretension 4...8 %

Order No.	Diameter Ø Outer		approx. weight kg/100m	Standard roll		Recommended min. pulley Ø		PT/DRIVE Fmax/belt Standard N	CONVEYANCE max. conveying weight, Standard		Suitable nipple type Order No.
	mm	inch		m	ft	mm	inch		kg	lbs	
FBHP75A048HI	4,8	3/16	1,8	200	656	30	1,2	19	3,7	8,2	FBN048
FBHP75A063HI	6,3	1/4	3,2	100	328	45	1,8	32	6,3	13,9	FBN063
FBHP75A080HI	8,0	5/16	5,1	100	328	55	2,2	51	10,1	22,3	FBN080N
FBHP75A095HI	9,5	3/8	7,2	100	328	65	2,6	71	14,3	31,5	FBN095
FBHP75A125HI	12,5	1/2	12,4	50	164	85	3,4	122	24,4	53,7	FBN125-150
FBHP75A150HI	15,0	19/32	19,0	50	164	100	4,0	187	37,3	82,2	FBN125-150

approx. Coefficient of friction μ : Steel: 0,70 | PE: 0,40 | HDPE: 0,35



PU85A yellow smooth



approx. 88° Shore A

Recommended pretension 4...8 %

Order No.	Diameter Ø Outer		approx. weight kg/100m	Standard roll		Recommended min. pulley Ø		PT/DRIVE Fmax/belt Standard N	CONVEYANCE max. conveying weight, Standard		Suitable nipple type Order No.
	mm	inch		m	ft	mm	inch		kg	lbs	
FBHP85A048GE	4,8	3/16	1,8	200	656	35	1,4	31	6,2	13,7	FBN048
FBHP85A063GE	6,3	1/4	3,2	100	328	55	2,2	53	10,5	23,2	FBN063
FBHP85A080GE	8,0	5/16	5,1	100	328	65	2,6	84	16,9	37,2	FBN080N
FBHP85A095GE	9,5	3/8	7,2	100	328	75	3,0	119	23,8	52,5	FBN095
FBHP85A125GE	12,5	1/2	12,4	50	164	100	3,9	203	40,6	89,5	FBN125-150
FBHP85A150GE	15,0	19/32	19,0	50	164	120	4,7	311	62,2	137,1	FBN125-150

approx. Coefficient of friction μ : Steel: 0,60 | PE: 0,35 | HDPE: 0,30

PU85A green rough



approx. 88° Shore A

Recommended pretension 4...8 %

Order No.	Diameter Ø Outer		approx. weight kg/100m	Standard roll		Recommended min. pulley Ø		PT/DRIVE Fmax/belt Standard N	CONVEYANCE max. conveying weight, Standard		Suitable nipple type Order No.
	mm	inch		m	ft	mm	inch		kg	lbs	
FBHP85A048R	4,8	3/16	1,8	200	656	35	1,4	31	6,2	13,7	FBN048
FBHP85A063R	6,3	1/4	3,2	100	328	55	2,2	53	10,5	23,2	FBN063
FBHP85A080R	8,0	5/16	5,1	100	328	65	2,6	84	16,9	37,2	FBN080N
FBHP85A095R	9,5	3/8	7,2	100	328	75	3,0	119	23,8	52,5	FBN095
FBHP85A125R	12,5	1/2	12,4	50	164	100	3,9	203	40,6	89,5	FBN125-150
FBHP85A150R	15,0	19/32	19,0	50	164	120	4,7	311	62,2	137,1	FBN125-150

approx. Coefficient of friction μ : Steel: 0,45 | PE: 0,35 | HDPE: 0,30

PU85A sapphire blue smooth

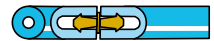

approx. 88° Shore A

Recommended pretension 4...8 %

Order No.	Diameter Ø Outer		approx. weight kg/100m	Standard roll		Recommended min. pulley Ø		PT/DRIVE Fmax/belt Standard N	CONVEYANCE max. conveying weight, Standard		Suitable nipple type Order No.
	mm	inch		m	ft	mm	inch		kg	lbs	
FBHK048LG	4,8	3/16	1,8	200	656	35	1,4	29	5,7	12,6	FBN048
FBHK063LG	6,3	1/4	3,2	100	328	55	2,2	48	9,7	21,3	FBN063
FBHK080LG	8,0	5/16	5,1	100	328	65	2,6	78	15,5	34,2	FBN080N
FBHK095LG	9,5	3/8	7,2	100	328	75	3,0	110	21,9	48,3	FBN095
FBHK125LG	12,5	1/2	12,4	50	164	100	3,9	187	37,3	82,3	FBN125-150
FBHK150LG	15,0	19/32	19,0	50	164	120	4,7	286	57,2	126,1	FBN125-150

approx. Coefficient of friction μ : Steel: 0,60 | PE: 0,35 | HDPE: 0,30

PU90A white smooth



approx. 92° Shore A

Recommended pretension 3...5 %

Order No.	Diameter Ø Outer		approx. weight kg/100m	Standard roll		Recommended min. pulley Ø		PT/DRIVE Fmax/belt Standard N	CONVEYANCE max. conveying weight, Standard		Suitable nipple type Order No.
	mm	inch		m	ft	mm	inch		kg	lbs	
FBHP90A048	4,8	3/16	1,8	200	656	45	1,8	36	7,2	15,8	FBN048
FBHP90A063	6,3	1/4	3,2	100	328	60	2,4	60	12,1	26,6	FBN063
FBHP90A080	8,0	5/16	5,1	100	328	75	3,0	97	19,4	42,8	FBN080N
FBHP90A095	9,5	3/8	7,2	100	328	85	3,4	137	27,4	60,4	FBN095
FBHP90A125	12,5	1/2	12,4	50	164	115	4,5	233	46,7	102,9	FBN125-150
FBHP90A150	15,0	19/32	19,0	50	164	140	5,5	358	71,5	157,6	FBN125-150

approx. Coefficient of friction μ : Steel: 0,50 | PE: 0,30 | HDPE: 0,25



Can Cables

The following round belts are specially designed for the transport of empty or filled cans on short or very long conveying distances.

Our professional welding technology ensures safe and durable joinings.

A special feature is the CRIMP connection for steel tension members (p. 110).

PU95A red smooth, reinforced Aramid



approx. 95° Shore A

Max. pretension

Standard	1,5 %
Overlap	1,5 %

Order No.	Diameter Ø		approx. weight kg/100m	Standard roll		Recommended min. pulley Ø		PT/DRIVE Fmax/belt		CONVEYANCE max. conveying weight			
	mm	inch		m	ft	mm	inch	Standard N	Overlap N	Standard		Overlap	
	mm	inch	kg/100m	m	ft	mm	inch	N	N	kg	lbs	kg	lbs
FBRN095RM	9,5	3/8	8,5	152	500	175	6,9	177	328	35,4	78,1	65,5	144,4
FBRN125RM	12,5	1/2	14,8	152	500	230	9,1	307	652	61,4	135,2	130,4	287,3

approx. Coefficient of friction μ : Steel: 0,40 | PE: 0,25 | HDPE: 0,20

For overlap splices, the recommended minimum pulley diameter must be increased by +30%.

PU95A red slightly rough, reinforced Aramid



approx. 95° Shore A

Max. pretension

Standard	1,5 %
Overlap	1,5 %

Order No.	Diameter Ø		approx. weight kg/100m	Standard roll		Recommended min. pulley Ø		PT/DRIVE Fmax/belt		CONVEYANCE max. conveying weight			
	mm	inch		m	ft	mm	inch	Standard N	Overlap N	Standard		Overlap	
	mm	inch	kg/100m	m	ft	mm	inch	N	N	kg	lbs	kg	lbs
FBRN095RMA	9,5	3/8	8,5	152	500	175	6,9	177	328	35,4	78,1	65,5	144,4

approx. Coefficient of friction μ : Steel: 0,40 | PE: 0,25 | HDPE: 0,20

For overlap splices, the recommended minimum pulley diameter must be increased by +30%.

TPE55D beige smooth, reinforced Steel



55° Shore D • approx. 100° Shore A

Max. pretension

CRIMP	1 %
-------	-----

Order No.	Diameter Ø		approx. weight kg/100m	Standard roll		Recommended min. pulley Ø		PT/DRIVE Fmax/belt		CONVEYANCE max. conveying weight			
	mm	inch		m	ft	mm	inch	Standard N	CRIMP* N	Standard		CRIMP*	
	mm	inch	kg/100m	m	ft	mm	inch	N	N	kg	lbs	kg	lbs
FBRS095BGB	9,5	3/8	8,5	500	1640	380	15,0	–	1125	–	–	225,0	495,9
FBRS125BGB	12,5	1/2	14,8	500	1640	380	15,0	–	1125	–	–	225,0	495,9

approx. Coefficient of friction μ : Steel: 0,35 | PE: 0,20 | HDPE: 0,15

TPE55D sky blue smooth, reinforced Aramid



Order No.	Diameter \varnothing		approx. weight kg/100m	Standard roll		Recommended min. pulley \varnothing		PT/DRIVE Fmax/belt Standard N	Overlap N	CONVEYANCE max. conveying weight			
	mm	inch		m	ft	mm	inch			Standard		Overlap	
										kg	lbs	kg	lbs
FBRS095LGA	9,5	3/8	8,5	152	500	175	6,9	340	687	68,0	150,0	137,5	303,0
FBRS125LGA	12,5	1/2	14,8	152	500	230	9,1	589	781	117,8	259,7	156,1	344,1

55° Shore D - approx. 100° Shore A

Max. pretension

Standard/ Overlap 1,5 %

approx. Coefficient of friction μ : Steel: 0,35 | PE: 0,20 | HDPE: 0,15

For overlap splices, the recommended minimum pulley diameter must be increased by +30%.

TPE63D silver smooth, reinforced Polyester



Order No.	Diameter \varnothing		approx. weight kg/100m	Standard roll		Recommended min. pulley \varnothing		PT/DRIVE Fmax/belt Standard N	Overlap N	CONVEYANCE max. conveying weight			
	mm	inch		m	ft	mm	inch			Standard		Overlap	
										kg	lbs	kg	lbs
FBRT095IGA	9,5	3/8	8,5	152	500	190	7,5	284	961	56,7	125,0	192,2	423,7
FBRT125IGA	12,5	1/2	14,8	152	500	270	10,6	491	1272	98,2	216,4	254,4	560,8

63° Shore D - approx. >100° Shore A

Max. pretension

Standard 2 %

Overlap 3 %

approx. Coefficient of friction μ : Steel: 0,30 | PE: 0,15 | HDPE: 0,10

For overlap splices, the recommended minimum pulley diameter must be increased by +30%.

TPE63D beige smooth, reinforced Polyester



Order No.	Diameter \varnothing		approx. weight kg/100m	Standard roll		Recommended min. pulley \varnothing		PT/DRIVE Fmax/belt Standard N	Overlap N	CONVEYANCE max. conveying weight			
	mm	inch		m	ft	mm	inch			Standard		Overlap	
										kg	lbs	kg	lbs
FBRT095NGA	9,5	3/8	8,5	152	500	190	7,5	284	961	56,7	125,0	192,2	423,7
FBRT125NGA	12,5	1/2	14,8	152	500	270	10,6	491	1272	98,2	216,4	254,4	560,8

63° Shore D - approx. >100° Shore A

Max. pretension

Standard 2 %

Overlap 3 %

approx. Coefficient of friction μ : Steel: 0,30 | PE: 0,15 | HDPE: 0,10

For overlap splices, the recommended minimum pulley diameter must be increased by +30%.

TPE63D beige smooth, reinforced Aramid



Order No.	Diameter \varnothing		approx. weight kg/100m	Standard roll		Recommended min. pulley \varnothing		PT/DRIVE Fmax/belt Standard N	Overlap N	CONVEYANCE max. conveying weight			
	mm	inch		m	ft	mm	inch			Standard		Overlap	
										kg	lbs	kg	lbs
FBRT095NGC	9,5	3/8	8,5	152	500	190	7,5	284	558	56,7	125,0	111,6	246,0
FBRT125NGC	12,5	1/2	14,8	152	500	270	10,6	491	765	98,2	216,4	153,1	337,4

63° Shore D - approx. >100° Shore A

Max. pretension

Standard/ Overlap 1,5 %

approx. Coefficient of friction μ : Steel: 0,30 | PE: 0,15 | HDPE: 0,10

For overlap splices, the recommended minimum pulley diameter must be increased by +30%.

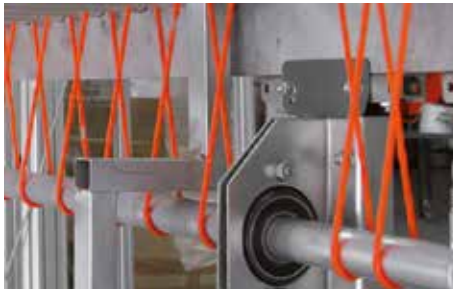

Twisted round belts / Belts with hook

Twisted round belts are the ideal solution for drive or transport systems in which several belts run on one shaft.

These belts are connected quickly, safely and easily by two hooks. The second hook is simply closed with a pair of pliers.

PU70A sky blue smooth



approx. 76° Shore A

Recommended pretension 8...10 %

Order No.	Diameter \varnothing		Recommended min. pulley \varnothing		PT/DRIVE Fmax/belt Standard N	Price scale pc.
	mm	inch	mm	inch		
FBXH3X250LG FBXH3X710LG	5,0	1/5	35	1,4	12	1/50/500

Available standard lengths of 250...710 mm

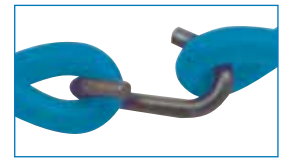

approx. Coefficient of friction μ : Steel: 0,75

PU75A plus orange smooth (matt)



approx. 80° Shore A

Recommended pretension 6...8 %

Order No.	Diameter \varnothing		Recommended min. pulley \varnothing		PT/DRIVE Fmax/belt Standard N	Price scale pc.
	mm	inch	mm	inch		
FBXI3X2500G FBXI3X7100G	5,0	1/5	40	1,6	24	1/50/500

Available standard lengths of 250...710 mm



approx. Coefficient of friction μ : Steel: 0,70

PU85A green rough



approx. 88° Shore A

Recommended pretension 6...8 %

Order No.	Diameter \varnothing		Recommended min. pulley \varnothing		PT/DRIVE Fmax/belt Standard N	Price scale pc.
	mm	inch	mm	inch		
FBXK3X250GR FBXK3X710GR	5,0	1/5	50	2	28	1/50/500

Available standard lengths of 250...710 mm



approx. Coefficient of friction μ : Steel: 0,45



Measuring the correct belt length from end to end (fabrication length Lf) without the hook.

Construction: 2 x \varnothing 3 mm (\varnothing 5 mm)

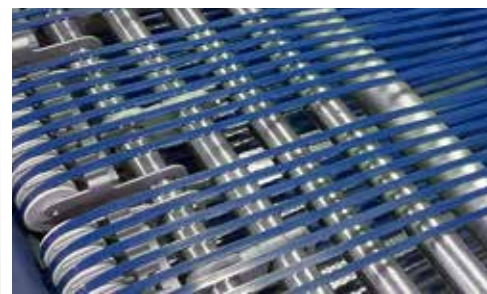

V-belts

Weldable V-belts made of PU and TPE are available in various Shore hardnesses and diameters for transport and power-transmission applications. Many belts are food-approved and equipped with various special properties for particularly demanding applications.

Typical industries are: food, logistics, printing & paper, packaging, building materials and many more.

PU75A red smooth

notched version possible



approx. 80° Shore A

Recommended pretension 4...8 %

Order No.	Profile dimension mm	approx. weight kg/100m	Standard roll		Recommended min. pulley Ø		PT/DRIVE Fmax/belt Standard N	CONVEYANCE max. conveying weight Standard	
			m	ft	mm	inch		kg	lbs
FBKP75A06	6 x 4 (Y)	2,3	100	328	35	1,4	25	5,0	11,0
FBKP75A08	8 x 5 (M)	4,0	100	328	40	1,6	43	8,5	18,8
FBKP75A10	10 x 6 (Z)	6,0	50	164	50	2,0	65	13,0	28,6
FBKP75A13	13 x 8 (A)	10,0	50	164	75	3,0	111	22,3	49,1
FBKP75A17	17 x 11 (B)	18,0	50	164	100	3,9	198	39,7	87,4
FBKP75A22	22 x 14 (C)	29,0	50	164	145	5,7	331	66,2	145,8
FBKP75A32	32 x 20 (D)	62,0	25	82	210	8,3	693	138,5	305,3

approx. Coefficient of friction μ : Steel: 0,70 | PE: 0,40 | HDPE: 0,35

PU75A sky blue smooth

notched version possible

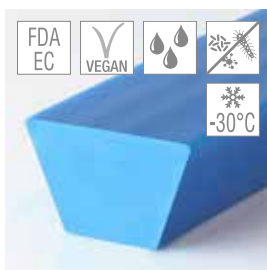

approx. 80° Shore A

Recommended pretension 4...8 %

Order No.	Profile dimension mm	approx. weight kg/100m	Standard roll		Recommended min. pulley Ø		PT/DRIVE Fmax/belt Standard N	CONVEYANCE max. conveying weight Standard	
			m	ft	mm	inch		kg	lbs
FBKI6YLGA	6 x 4 (Y)	2,3	100	328	35	1,4	22	4,4	9,7
FBKI8MLGA	8 x 5 (M)	4,0	100	328	40	1,6	38	7,5	16,6
FBKI10ZLGA	10 x 6 (Z)	6,0	50	164	50	2,0	57	11,5	25,3
FBKI13ALGA	13 x 8 (A)	10,0	50	164	75	3,0	98	19,7	43,4
FBKI17BLGA	17 x 11 (B)	18,0	50	164	100	3,9	175	35,0	77,1

approx. Coefficient of friction μ : Steel: 0,70 | PE: 0,40 | HDPE: 0,35

PU75A light grey, reinforced Polyester

notched version possible 

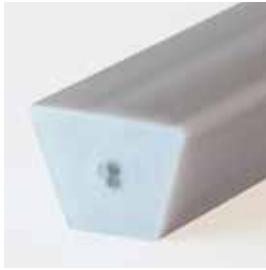

approx. 80° Shore A

Max. pretension

Standard	2 %
Overlap	3 %

Order No.	Profile dimension mm	approx. weight kg/100m	Standard roll		Recommended min. pulley Ø		PT/DRIVE Fmax/belt Standard		CONVEYANCE max. conveying weight			
			m	ft	mm	inch	N	Overlap N	Standard kg	Standard lbs	Overlap kg	Overlap lbs
FBK113AHGA	13 x 8 (A)	10,0	50	164	75	3,0	111	221	22,3	49,1	44,1	97,2
FBK117BHGA	17 x 11 (B)	18,0	50	164	100	3,9	198	610	39,7	87,4	122,1	269,0
FBK122CHGA	22 x 14 (C)	29,0	50	164	140	5,5	331	909	66,2	145,8	181,7	400,5

approx. Coefficient of friction μ : Steel: 0,70 | PE: 0,40 | HDPE: 0,35

PU75A orange, reinforced glass fibre PU

notched version possible 



approx. 80° Shore A

Recommended pretension 0,5...2 %

Order No.	Profile dimension mm	approx. weight kg/100m	Standard roll		Recommended min. pulley Ø		PT/DRIVE Fmax/belt Standard N	CONVEYANCE max. conveying weight Standard	
			m	ft	mm	inch		kg	lbs
FBZKP75A13GL	13 x 8 (A)	10,0	50	164	110	4,4	97	19,3	42,6
FBZKP75A17GL	17 x 11 (B)	18,0	50	164	140	5,5	172	34,4	75,9
FBZKP75A22GL	22 x 14 (C)	29,0	50	164	180	7,1	204	40,9	90,1

approx. Coefficient of friction μ : Steel: 0,70 | PE: 0,40 | HDPE: 0,35

PU80A orange smooth

notched version possible 



approx. 84° Shore A

Recommended pretension 4...8 %

Order No.	Profile dimension mm	approx. weight kg/100m	Standard roll		Recommended min. pulley Ø		PT/DRIVE Fmax/belt Standard N	CONVEYANCE max. conveying weight Standard	
			m	ft	mm	inch		kg	lbs
FBJ6YOG	6 x 4 (Y)	2,3	30	100	40	1,6	31	6,1	13,5
FBJ8MOG	8 x 5 (M)	4,0	30	100	45	1,8	53	10,5	23,2
FBJ10ZOG	10 x 6 (Z)	6,0	30	100	55	2,2	80	16,0	35,4
FBJ13AOG	13 x 8 (A)	10,0	30	100	85	3,3	138	27,5	60,7
FBJ17BOG	17 x 11 (B)	18,0	30	100	110	4,3	245	49,0	108,0
FBJ22COG	22 x 14 (C)	29,0	30	100	150	5,9	409	81,7	180,1
FBJ32DOG	32 x 20 (D)	62,0	30	100	220	8,7	856	171,1	377,1

approx. Coefficient of friction μ : Steel: 0,65 | PE: 0,35 | HDPE: 0,30

PU80A orange smooth, reinforced Polyester

notched version possible 



approx. 84° Shore A	
Max. pretension	
Standard	2 %
Overlap	3 %

Order No.	Profile dimension	approx. weight	Standard roll		Recommended min. pulley \varnothing		PT/DRIVE Fmax/belt		CONVEYANCE max. conveying weight			
			mm	kg/100m	m	ft	mm	inch	Standard	Overlap	Standard	Overlap
FBJ8MOGA	8 x 5 (M)	4,0	30	100	50	2,0	53	152	10,5	23,2	30,5	67,1
FBJ10ZOGA	10 x 6 (Z)	6,0	30	100	60	2,4	80	163	16,0	35,4	32,5	71,7
FBJ13AOGA	13 x 8 (A)	10,0	30	100	85	3,3	138	230	27,5	60,7	46,1	101,6
FBJ17BOGA	17 x 11 (B)	18,0	30	100	110	4,3	245	628	49,0	108,0	125,6	276,7
FBJ17BOGC	17 x 11 (B)	18,0	100	328	110	4,3	245	628	49,0	108,0	125,6	276,7
FBJ22COGA	22 x 14 (C)	29,0	30	100	150	5,9	409	938	81,7	180,1	187,5	413,4
FBJ32DOGA	32 x 20 (D)	62,0	30	100	220	8,7	856	1105	171,1	377,1	221,1	487,2

approx. Coefficient of friction μ : Steel: 0,65 | PE: 0,35 | HDPE: 0,30

PU80A transparent smooth

notched version possible 

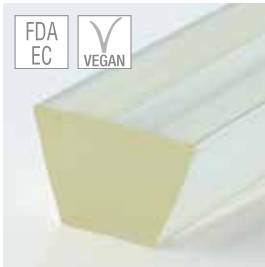

approx. 84° Shore A	
Recommended pretension	4...8 %

Order No.	Profile dimension	approx. weight	Standard roll		Recommended min. pulley \varnothing		PT/DRIVE Fmax/belt Standard	CONVEYANCE max. conveying weight Standard	
			mm	kg/100m	m	ft		mm	inch
FBKP80A06TR	6 x 4 (Y)	2,3	100	328	40	1,6	31	6,1	13,5
FBKP80A08TR	8 x 5 (M)	4,0	100	328	45	1,8	53	10,5	23,2
FBKP80A10TR	10 x 6 (Z)	6,0	50	164	55	2,2	80	16,0	35,4
FBKP80A13TR	13 x 8 (A)	10,0	50	164	85	3,3	138	27,5	60,7
FBKP80A17TR	17 x 11 (B)	18,0	50	164	110	4,3	245	49,0	108,0
FBKP80A22TR	22 x 14 (C)	29,0	50	164	150	5,9	409	81,7	180,1
FBKP80A32TR	32 x 20 (D)	62,0	25	82	220	8,7	856	171,1	377,1

approx. Coefficient of friction μ : Steel: 0,65 | PE: 0,35 | HDPE: 0,30

PU80A ultramarine blue smooth

notched version possible 



approx. 84° Shore A	
Recommended pretension	4...8 %

Order No.	Profile dimension	approx. weight	Standard roll		Recommended min. pulley \varnothing		PT/DRIVE Fmax/belt Standard	CONVEYANCE max. conveying weight Standard	
			mm	kg/100m	m	ft		mm	inch
FBKJ06YZLG	6 x 4 (Y)	2,3	100	328	40	1,6	28	5,6	12,3
FBKJ08MLG	8 x 5 (M)	4,0	100	328	45	1,8	48	9,5	21,0
FBKJ10ZLG	10 x 6 (Z)	6,0	50	164	55	2,2	73	14,5	32,0

approx. Coefficient of friction μ : Steel: 0,65 | PE: 0,35 | HDPE: 0,30

PU80A safe capri blue smooth

notched version possible 

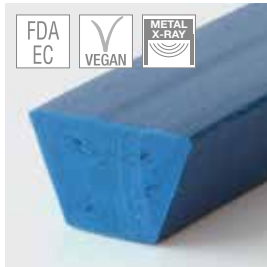

approx. 84° Shore A

Recommended pretension 3...6 %

Order No.	Profile dimension	approx. weight	Standard roll		Recommended min. pulley Ø		PT/DRIVE Fmax/belt Standard	CONVEYANCE max. conveying weight Standard	
			mm	kg/100m	m	ft		mm	inch
FBKJ6YLGM	6 x 4 (Y)	2,3	100	328	40	1,6	23	4,6	10,2
FBKJ8MLGM	8 x 5 (M)	4,0	100	328	45	1,8	40	7,9	17,4
FBKJ10ZLGM	10 x 6 (Z)	6,0	50	164	55	2,2	60	12,0	26,5
FBKJ13ALGM	13 x 8 (A)	10,0	50	164	85	3,3	103	20,7	45,5
FBKJ17BLGM	17 x 11 (B)	18,0	50	164	110	4,3	184	36,8	81,0
FBKJ22CLGM	22 x 14 (C)	29,0	50	164	150	6,0	306	61,3	135,1

approx. Coefficient of friction μ : Steel: 0,65 | PE: 0,35 | HDPE: 0,30

PU85A sapphire blue smooth

notched version possible 



approx. 88° Shore A

Recommended pretension 4...8 %

Order No.	Profile dimension	approx. weight	Standard roll		Recommended min. pulley Ø		PT/DRIVE Fmax/belt Standard	CONVEYANCE max. conveying weight Standard	
			mm	kg/100m	m	ft		mm	inch
FBKK06MLGAAA	6 x 4 (Y)	2,3	100	328	45	1,8	34	6,7	14,8
FBKK08MLGAAA	8 x 5 (M)	4,0	100	328	50	2,0	58	11,5	25,4
FBKK10ZLGAAA	10 x 6 (Z)	6,0	50	164	65	2,6	88	17,6	38,7
FBKK13ALGAAA	13 x 8 (A)	10,0	50	164	95	3,8	151	30,2	66,5
FBKK17BLGAAA	17 x 11 (B)	18,0	50	164	120	4,7	268	53,7	118,3
FBKK22CLGAAA	22 x 14 (C)	29,0	50	164	165	6,5	448	89,5	197,3

approx. Coefficient of friction μ : Steel: 0,60 | PE: 0,35 | HDPE: 0,30

PU85A sapphire blue smooth, reinforced Polyester

notched version possible 



approx. 88° Shore A

Max. pretension

Standard 2 %

Overlap 3 %

Order No.	Profile dimension	approx. weight	Standard roll		Recommended min. pulley Ø		PT/DRIVE Fmax/belt Standard	Overlap	CONVEYANCE max. conveying weight			
			mm	kg/100m	m	ft			mm	inch	N	kg
FBZKP85A13PS	13 x 8 (A)	10,0	50	164	95	3,8	151	189	30,2	66,5	37,8	83,3
FBZKP85A17PS	17 x 11 (B)	18,0	50	164	120	4,7	268	279	53,7	118,3	55,9	123,2
FBZKP85A22PS	22 x 14 (C)	29,0	50	164	165	6,5	448	704	89,5	197,3	140,7	310,2

approx. Coefficient of friction μ : Steel: 0,60 | PE: 0,35 | HDPE: 0,30

PU85A green smooth

notched version possible



Order No.	Profile dimension	approx. weight	Standard roll		Recommended min. pulley \varnothing		PT/DRIVE Fmax/belt Standard	CONVEYANCE max. conveying weight Standard	
			mm	kg/100m	m	ft		mm	inch
FBKP85A06	6 x 4 (Y)	2,3	100	328	45	1,8	37	7,3	16,1
FBKP85A08	8 x 5 (M)	4,0	100	328	50	2,0	63	12,5	27,6
FBKP85A10	10 x 6 (Z)	6,0	50	164	65	2,6	96	19,1	42,1
FBKP85A13	13 x 8 (A)	10,0	50	164	95	3,8	164	32,8	72,3
FBKP85A17	17 x 11 (B)	18,0	50	164	120	4,7	292	58,3	128,6
FBKP85A22	22 x 14 (C)	29,0	50	164	165	6,5	486	97,3	214,4
FBKP85A32	32 x 20 (D)	62,0	25	82	250	9,8	1019	203,7	449,0

approx. 88° Shore A

Recommended pretension 4...8 %

approx. Coefficient of friction μ : Steel: 0,60 | PE: 0,35 | HDPE: 0,30

PU85A green, reinforced Aramid

notched version possible



Order No.	Profile dimension	approx. weight	Standard roll		Recommended min. pulley \varnothing		PT/DRIVE Fmax/belt Standard	Overlap N	CONVEYANCE max. conveying weight			
			mm	kg/100m	m	ft			mm	inch	Standard kg	Standard lbs
FBZKP85A08A	8 x 5 (M)	4,0	100	328	60	2,4	63	177	12,5	27,6	35,5	78,2
FBZKP85A10A	10 x 6 (Z)	6,0	50	164	70	2,8	96	184	19,1	42,1	36,7	80,9
FBZKP85A13A	13 x 8 (A)	10,0	50	164	100	3,9	164	305	32,8	72,3	61,0	134,5
FBZKP85A17A	17 x 11 (B)	18,0	50	164	140	5,5	292	329	58,3	128,6	65,8	145,1
FBZKP85A22A	22 x 14 (C)	29,0	50	164	180	7,1	486	651	97,3	214,4	130,2	287,0
FBKK32DGGA	32 x 20 (D)	62,0	40	131	275	10,8	1019	–	203,7	449,0	–	–

approx. 88° Shore A

Max. pretension

Standard 1,5 %

Overlap 1,5 %

approx. Coefficient of friction μ : Steel: 0,60 | PE: 0,35 | HDPE: 0,30

PU85A plus blue smooth

notched version possible



Order No.	Profile dimension	approx. weight	Standard roll		Recommended min. pulley \varnothing		PT/DRIVE Fmax/belt Standard	CONVEYANCE max. conveying weight Standard	
			mm	kg/100m	m	ft		mm	inch
FBKP85A06BP	6 x 4 (Y)	2,3	100	328	45	1,8	35	7,0	15,5
FBKP85A08BP	8 x 5 (M)	4,0	100	328	50	2,0	60	12,0	26,5
FBKP85A10BP	10 x 6 (Z)	6,0	50	164	65	2,6	92	18,3	40,4
FBKP85A13BP	13 x 8 (A)	10,0	50	164	95	3,8	157	31,5	69,4
FBKP85A17BP	17 x 11 (B)	18,0	50	164	120	4,7	280	56,0	123,4
FBKP85A22BP	22 x 14 (C)	29,0	50	164	165	6,5	467	93,4	205,8
FBKP85A32BP	32 x 20 (D)	62,0	25	82	250	9,8	978	195,6	431,0

approx. 88° Shore A

Recommended pretension 3...6 %

approx. Coefficient of friction μ : Steel: 0,60 | PE: 0,35 | HDPE: 0,30

PU85A ultramarine blue, reinforced glass fibre PU

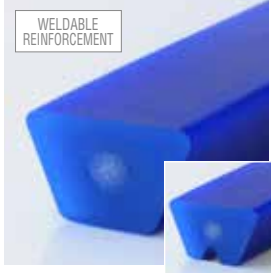

Order No.	Profile dimension	approx. weight	Standard roll		Recommended min. pulley \varnothing		PT/DRIVE Fmax/belt Standard N	CONVEYANCE max. conveying weight Standard	
			mm	kg/100m	m	ft		mm	inch
FBZKP85A13	13 x 8 (A)	10,0	50	164	125	4,9	108	21,6	47,7
FBZKP85A17 (groove)	17 x 11 (B)	18,0	50	164	180	7,1	193	38,5	84,9
FBZKP85A22 (groove)	22 x 14 (C)	29,0	50	164	220	8,7	243	48,6	107,2

approx. 88° Shore A

Recommended pretension 0,5...2%

approx. Coefficient of friction μ : Steel: 0,60 | PE: 0,35 | HDPE: 0,30

PU90A white smooth

notched version possible 



Order No.	Profile dimension	approx. weight	Standard roll		Recommended min. pulley \varnothing		PT/DRIVE Fmax/belt Standard N	CONVEYANCE max. conveying weight Standard	
			mm	kg/100m	m	ft		mm	inch
FBKP90A08	8 x 5 (M)	4,0	100	328	60	2,4	72	14,4	31,8
FBKP90A10	10 x 6 (Z)	6,0	50	164	80	3,2	110	22,0	48,4
FBKP90A13	13 x 8 (A)	10,0	50	164	105	4,2	189	37,7	83,1
FBKP90A17	17 x 11 (B)	18,0	50	164	140	5,5	335	67,1	147,9
FBKP90A22	22 x 14 (C)	29,0	50	164	200	7,9	559	111,9	246,6
FBKP90A32 (nature)	32 x 20 (D)	62,0	25	82	320	12,6	1171	234,3	516,3

approx. 92° Shore A

Recommended pretension 3...5%

approx. Coefficient of friction μ : Steel: 0,50 | PE: 0,30 | HDPE: 0,25

PU90A white, reinforced Polyester

notched version possible 



Order No.	Profile dimension	approx. weight	Standard roll		Recommended min. pulley \varnothing		PT/DRIVE Fmax/belt Standard N	Overlap N	CONVEYANCE max. conveying weight Standard			
			mm	kg/100m	m	ft			mm	inch	kg	lbs
FBZKP90A08P	8 x 5 (M)	4,0	100	328	65	2,6	72	176	14,4	31,8	35,2	77,5
FBZKP90A10P	10 x 6 (Z)	6,0	50	164	85	3,3	110	245	22,0	48,4	48,9	107,8
FBZKP90A13P	13 x 8 (A)	10,0	50	164	110	4,3	189	292	37,7	83,1	58,4	128,6
FBZKP90A17P	17 x 11 (B)	18,0	50	164	150	5,9	335	737	67,1	147,9	147,4	324,9
FBZKP90A22P	22 x 14 (C)	29,0	50	164	210	8,3	559	1120	111,9	246,6	224,0	493,8

approx. 92° Shore A

Max. pretension

Standard 2%

Overlap 3%

approx. Coefficient of friction μ : Steel: 0,50 | PE: 0,30 | HDPE: 0,25

PU95A beige, reinforced Polyester

notched version possible 

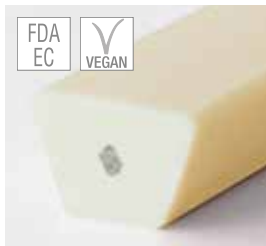

Order No.	Profile dimension	approx. weight	Standard roll		Recommended min. pulley \varnothing		PT/DRIVE Fmax/belt		CONVEYANCE max. conveying weight				
			mm	kg/100m	m	ft	mm	inch	Standard	Overlap	Standard		Overlap
								N	N	kg	lbs	kg	lbs
FBKM13ABGA	13 x 8 (A)	10,0	50	164	130	5,0	205	302	41,0	90,3	60,3	133,0	
FBKM17BBGA	17 x 11 (B)	18,0	50	164	175	6,8	365	755	72,9	160,7	150,9	332,7	
FBKM22CBGA	22 x 14 (C)	29,0	50	164	250	9,7	608	1149	121,6	268,0	229,9	506,6	

approx. 95° Shore A

Max. pretension

Standard 2 %

Overlap 3 %

approx. Coefficient of friction μ : Steel: 0,45 | PE: 0,25 | HDPE: 0,20

TPE40D beige smooth

notched version possible 

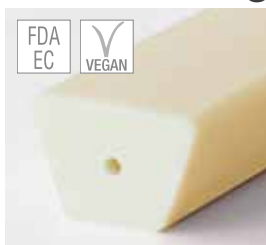

Order No.	Profile dimension	approx. weight	Standard roll		Recommended min. pulley \varnothing		PT/DRIVE Fmax/belt Standard	CONVEYANCE max. conveying weight	
			mm	kg/100m	m	ft		mm	inch
FBKR08MBG	8 x 5 (M)	4,0	100	328	60	2,4	73	14,5	32,1
FBKR10ZBG	10 x 6 (Z)	6,0	50	164	80	3,2	111	22,2	48,8
FBKR13ABG	13 x 8 (A)	10,0	50	164	105	4,2	190	38,0	83,8
FBKR17BBG	17 x 11 (B)	18,0	50	164	140	5,5	338	67,7	149,2
FBKR22CBG	22 x 14 (C)	29,0	50	164	200	7,9	564	112,9	248,7

40° Shore D · approx. 95° Shore A

Recommended pretension 2...4 %

approx. Coefficient of friction μ : Steel: 0,50 | PE: 0,25 | HDPE: 0,20

TPE55D beige / blue smooth

notched version possible 

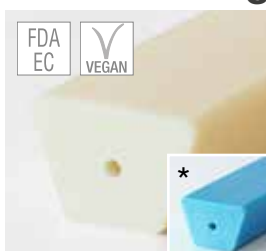

Order No.	Profile dimension	approx. weight	Standard roll		Recommended min. pulley \varnothing		PT/DRIVE Fmax/belt Standard	CONVEYANCE max. conveying weight	
			mm	kg/100m	m	ft		mm	inch
FBKH55D08B (beige)	8 x 5 (M)	4,0	100	328	80	3,2	150	30,1	66,3
FBKH55D10B (beige)	10 x 6 (Z)	6,0	50	164	105	4,2	229	45,8	101,0
FBKH55D13B (beige)	13 x 8 (A)	10,0	50	164	130	5,1	393	78,7	173,4
FBKH55D17 (blue)*	17 x 11 (B)	18,0	50	164	175	7	700	140,0	308,6
FBKH55D22B (beige)	22 x 14 (C)	29,0	50	164	250	9,8	1167	233,5	514,6

55° Shore D · approx. 100° Shore A

Recommended pretension 2...4 %

approx. Coefficient of friction μ : Steel: 0,35 | PE: 0,20 | HDPE: 0,15

TPE55D beige, reinforced Polyester

notched version possible 



Order No.	Profile dimension	approx. weight	Standard roll		Recommended min. pulley \varnothing		PT/DRIVE Fmax/belt		CONVEYANCE max. conveying weight				
			mm	kg/100m	m	ft	mm	inch	Standard	Overlap	Standard		Overlap
								N	N	kg	lbs	kg	lbs
FBKH55D10P	10 x 6 (Z)	6,0	50	164	110	4,4	229	351	45,8	101,0	70,1	154,6	
FBKH55D13P	13 x 8 (A)	10,0	50	164	135	5,3	393	474	78,7	173,4	94,8	208,9	
FBKH55D17P	17 x 11 (B)	18,0	50	164	190	7,2	700	1061	140,0	308,6	212,2	467,7	
FBKH55D22P	22 x 14 (C)	29,0	50	164	260	10,2	1167	1660	233,5	514,6	332,0	731,8	

55° Shore D · approx. 100° Shore A

Max. pretension

Standard 2 %

Overlap 3 %

approx. Coefficient of friction μ : Steel: 0,35 | PE: 0,20 | HDPE: 0,15

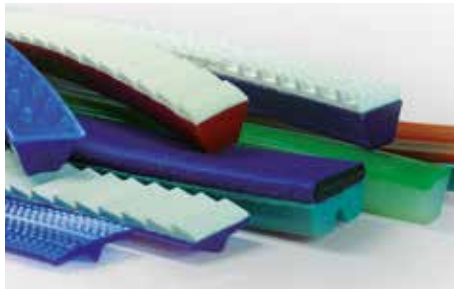

Coatings and embossings

The application of coatings to V-belts enables specific material properties, e.g. better grip, accumulation or better release on a durable base belt. The „PUTex“ coating is the alternative to Linatex (rubber) in dry applications. A direct variant for optimising the conveying process is embossing the profile surfaces.

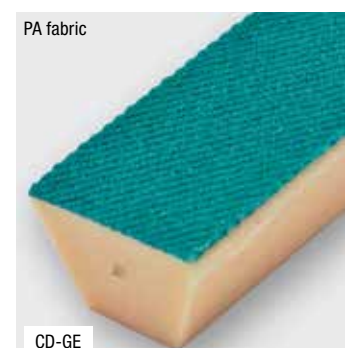
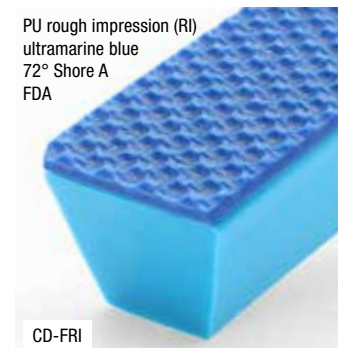

Embossings

- EST** Saw Tooth
- ESG** Supergrip
- EID** Diamond
- EFI** Fabric Impression
- EMS** Mini Saw Tooth



Twin V-belts | Shore 80 A, 84 A



Twin V-belts

Twin V-belts are an ideal solution for stable conveying or for spreading product strands in the food industry. Our portfolio includes various design variants, Shore hardness grades and reinforced products.

PU75A red smooth



approx. 80° Shore A

Recommended pretension 3...6 %

Order No.	Profile dimension mm	approx. weight kg/100m	Standard roll		Recommended min. pulley \varnothing		PT/DRIVE Fmax/belt Standard N	CONVEYANCE max. conveying weight Standard	
			m	ft	mm	inch		kg	lbs
F BSP75A21X8	21 x 8	14,0	30	100	60	2,3	122	24,5	54,0

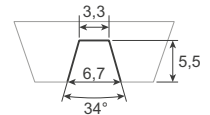

approx. Coefficient of friction μ : Steel: 0,70 | PE: 0,40 | HDPE: 0,35

PU75A sky blue smooth

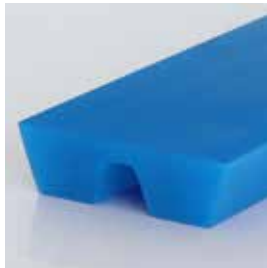

approx. 80° Shore A

Recommended pretension 3...6 %

Order No.	Profile dimension mm	approx. weight kg/100m	Standard roll		Recommended min. pulley \varnothing		PT/DRIVE Fmax/belt Standard N	CONVEYANCE max. conveying weight Standard	
			m	ft	mm	inch		kg	lbs
FBSI30X8LG	30 x 8	22,4	50	164	60	2,3	194	38,8	85,4

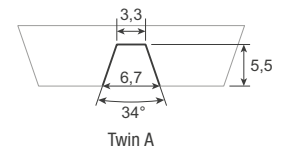

Approx. coefficient of friction μ : Steel: 0,70 | PE: 0,40 | HDPE: 0,35

PU80A orange/ultramarine blue smooth



approx. 84° Shore A

Recommended pretension 3...6 %

Order No.	Color	Profile dimension mm	approx. weight kg/100m	Standard roll		Recommended min. pulley \varnothing		PT/DRIVE Fmax/belt Standard N	CONVEYANCE max. conveying weight Standard	
				m	ft	mm	inch		kg	lbs
FBSJ23X68LGB	Blue	24 x 6,8	14,4	30	100	60	2,4	151	30,2	66,6
FBSJ24X680GB	Blue	24 x 6,8	14,4	30	100	60	2,4	151	30,2	66,6
F BSP80A21X8	Orange	21 x 8	14,0	30	100	80	3,1	151	30,2	66,6
FBSJ30X80G	Orange	30 x 8	22,4	30	100	80	3,1	239	47,9	105,5
FBSJ30X80GC	Orange	30 x 8	22,4	30	100	80	3,1	239	47,9	105,5

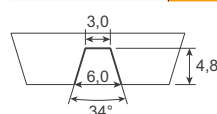

FBSJ23X68LGB
FBSJ24X680GB
(Twin Z / 3L)

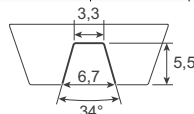

F BSP80A21X8

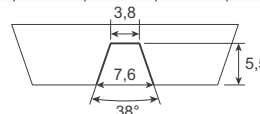

FBSJ30X80G

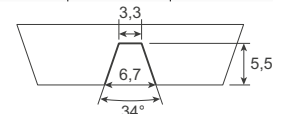

FBSJ30X80GC
(Twin A)

approx. Coefficient of friction μ : Steel: 0,65 | PE: 0,35 | HDPE: 0,30

PU80A orange smooth, reinforced Polyester



approx. 84° Shore A
Max. pretension
Standard 2%
Overlap 3%

Order No.	Profile dimension mm	approx. weight kg/100m	Standard roll		Recommended min. pulley \varnothing		PT/DRIVE Fmax/belt		CONVEYANCE max. conveying weight			
			m	ft	mm	inch	Standard N	Overlap N	Standard kg	Standard lbs	Overlap kg	Overlap lbs
FBSJ21X80GA	21 x 8	14,4	30	100	80	3,1	151	341	30,2	66,6	68,1	150,1
FBSJ30X80GD	30 x 8	22,4	30	100	80	3,1	239	385	47,9	105,5	76,9	169,6

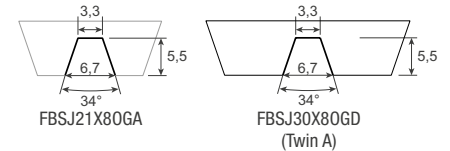

approx. Coefficient of friction μ : Steel: 0,65 | PE: 0,35 | HDPE: 0,30

For overlap splices, the recommended minimum pulley diameter must be increased by +30%.

PU85A mint green smooth, reinforced Polyester

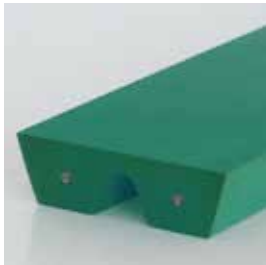

approx. 88° Shore A
Max. pretension
Standard 2%
Overlap 3%

Order No.	Profile dimension mm	approx. weight kg/100m	Standard roll		Recommended min. pulley \varnothing		PT/DRIVE Fmax/belt		CONVEYANCE max. conveying weight			
			m	ft	mm	inch	Standard N	Overlap N	Standard kg	Standard lbs	Overlap kg	Overlap lbs
FBSK30X8GGA	30 x 8	22,4	30	100	100	3,9	380	500	76,0	167,5	100,0	220,4

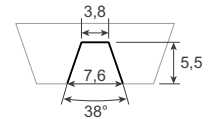

approx. Coefficient of friction μ : Steel: 0,60 | PE: 0,35 | HDPE: 0,30

For overlap splices, the recommended minimum pulley diameter must be increased by +30%.

PU95A beige



approx. 95° Shore A
Recommended pretension 3...5 %

Order No.	Profile dimension mm	approx. weight kg/100m	Standard roll		Recommended min. pulley \varnothing		PT/DRIVE Fmax/belt		CONVEYANCE max. conveying weight	
			m	ft	mm	inch	Standard N	Standard kg	Standard lbs	
FBSJ24X68BGB	24 x 6,8	15	30	100	100	3,9	315	63,0	138,9	
FBSJ30X8BGB	30 x 8	22,4	50	164	120	4,7	420	84,0	185,2	

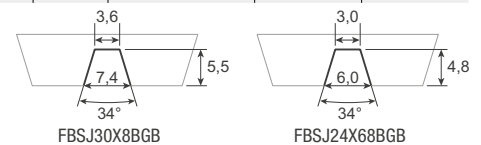

approx. coefficient of friction μ : Steel: 0,45 | PE: 0,25 | HDPE: 0,20

PVC Supergrip coating

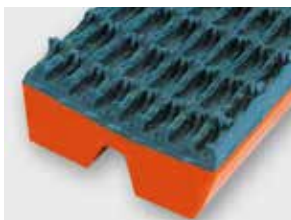

PU75A Twin V-belt (24 x 6,8 mm) with PVC Supergrip coating (CD-SG).

Neoprene coating / unscrambler belt

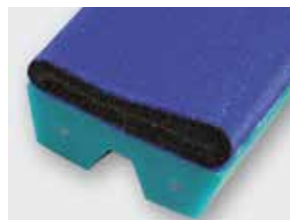

PU85A Twin-V-belt (30 x 8 mm) with reinforcement Polyester and neoprene coating (CD-ZK). Especially for PET bottle transport / guide.

Special designs Twin V-belt



Further details can be found on page 50.

Ridge top V-belts | Shore 80 A, 84 A



Ridge Top V-belts for the building material and tile industry

Ridge Top V-belts have a high wear resistance against heavy and abrasive building materials. Available in various Shore hardness grades for variable conveying distances. These BEHAbelt belts are made of 100% PU or TPE and are therefore easy and quick to weld.

PU80A transparent



Order No.	Profile dimension mm	approx. weight kg/100m	Standard roll		Recommended min. pulley \varnothing		PT/DRIVE Fmax/belt Standard N	CONVEYANCE max. conveying weight Standard	
			m	ft	mm	inch		kg	lbs
FBBJ17X19TGO	17 x 19	25,6	30	100	160	6,3	268	53,7	118,3
FBBJ22X25TGO	22 x 25	43,8	30	100	210	8,4	460	92,0	202,7

approx. 84° Shore A

Recommended pretension 3...6 %

approx. Coefficient of friction μ : Steel: 0,65 | PE: 0,35 | HDPE: 0,30

PU80A transparent, reinforced Polyester

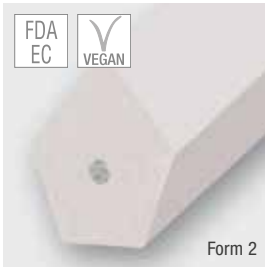

Order No.	Profile dimension mm	approx. weight kg/100m	Standard roll		Recommended min. pulley \varnothing		PT/DRIVE Fmax/belt Standard N	CONVEYANCE max. conveying weight Standard	
			m	ft	mm	inch		kg	lbs
FBBJ17X19TGA	17 x 19	25,6	30	100	160	6,3	268	53,7	118,3
FBBJ22X25TGA	22 x 25	43,8	30	100	210	8,4	460	92,0	202,7

approx. 84° Shore A

Max. pretension

Standard 2 %

approx. Coefficient of friction μ : Steel: 0,65 | PE: 0,35 | HDPE: 0,30

PU85A green

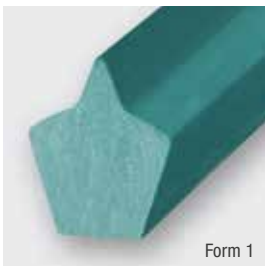

Order No.	Profile dimension mm	approx. weight kg/100m	Standard roll		Recommended min. pulley \varnothing		PT/DRIVE Fmax/belt Standard N	CONVEYANCE max. conveying weight Standard	
			m	ft	mm	inch		kg	lbs
FBSP85A170N	17 x 19	23,6	30	100	180	7,2	293	58,5	128,9
FBSP85A220N	22 x 25	39,1	30	100	220	8,8	489	97,8	215,6

approx. 88° Shore A

Recommended pretension 3...6 %

approx. Coefficient of friction μ : Steel: 0,60 | PE: 0,35 | HDPE: 0,30

PU85A green

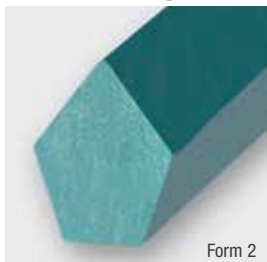

Form 2

approx. 88° Shore A

Recommended pretension 3...6 %

Order No.	Profile dimension mm	approx. weight kg/100m	Standard roll		Recommended min. pulley \varnothing		PT/DRIVE Fmax/belt Standard N	CONVEYANCE max. conveying weight Standard	
			m	ft	mm	inch		kg	lbs
FBAK17X19GG	17 x 19	25,6	30	100	190	7,6	320	63,9	140,8
FBAK22X25GG	22 x 25	43,8	30	100	240	9,6	548	109,5	241,3

approx. Coefficient of friction μ : Steel: 0,60 | PE: 0,35 | HDPE: 0,30

PU85A green, reinforced Polyester



Form 2

approx. 88° Shore A

Max. pretension

Standard 2 %

Order No.	Profile dimension mm	approx. weight kg/100m	Standard roll		Recommended min. pulley \varnothing		PT/DRIVE Fmax/belt Standard N	CONVEYANCE max. conveying weight Standard	
			m	ft	mm	inch		kg	lbs
FBBK17X19GGA	17 x 19	25,6	30	100	190	7,6	320	63,9	140,8
FBBK22X25GGA	22 x 25	43,8	30	100	240	9,6	548	109,5	241,3

approx. Coefficient of friction μ : Steel: 0,60 | PE: 0,35 | HDPE: 0,30

PU85A blue, reinforced glass fibre PU



Form 1

approx. 88° Shore A

Recommended pretension 0,5...2 %

Order No.	Profile dimension mm	approx. weight kg/100m	Standard roll		Recommended min. pulley \varnothing		PT/DRIVE Fmax/belt Standard N	CONVEYANCE max. conveying weight Standard	
			m	ft	mm	inch		kg	lbs
FBZSP85A17ON	17 x 19	23,63	30	100	240	9,6	218	43,7	96,3
FBZSP85A22ON	22 x 25	39,1	30	100	280	11,2	287	57,4	126,5

approx. Coefficient of friction μ : Steel: 0,60 | PE: 0,35 | HDPE: 0,30

PU85A blue, reinforced glass fibre PU



Form 2

approx. 88° Shore A

Recommended pretension 0,5...2 %

Order No.	Profile dimension mm	approx. weight kg/100m	Standard roll		Recommended min. pulley \varnothing		PT/DRIVE Fmax/belt Standard N	CONVEYANCE max. conveying weight Standard	
			m	ft	mm	inch		kg	lbs
FBBK17X19LGA	17 x 19	25,6	30	100	260	10,4	226	45,2	99,5
FBBK22X25LGA	22 x 25	43,8	30	100	300	12,0	307	61,3	135,1

approx. Coefficient of friction μ : Steel: 0,60 | PE: 0,35 | HDPE: 0,30

PU95A beige

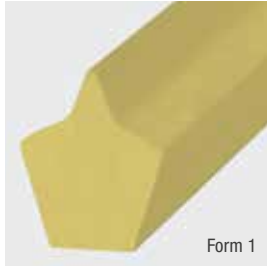

Form 1

approx. 95° Shore A

Recommended pretension 3...5 %

Order No.	Profile dimension mm	approx. weight kg/100m	Standard roll		Recommended min. pulley \varnothing		PT/DRIVE Fmax/belt Standard N	CONVEYANCE max. conveying weight Standard	
			m	ft	mm	inch		kg	lbs
FBAM17X19BG	17 x 19	23,6	30	100	200	8	488	97,5	214,9
FBAM22X25BG	22 x 25	39,1	30	100	250	10	815	163,0	359,3

approx. Coefficient of friction μ : Steel: 0,45 | PE: 0,25 | HDPE: 0,20

PU95A beige

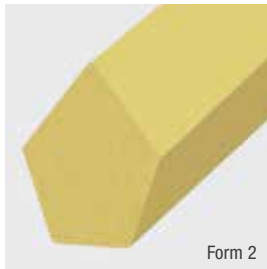

Form 2

approx. 95° Shore A

Recommended pretension 3...5 %

Order No.	Profile dimension mm	approx. weight kg/100m	Standard roll		Recommended min. pulley \varnothing		PT/DRIVE Fmax/belt Standard N	CONVEYANCE max. conveying weight Standard	
			m	ft	mm	inch		kg	lbs
FBBM17X19BG	17 x 19	25,6	30	100	210	8,4	533	106,5	234,7
FBBM22X25BG	22 x 25	43,8	30	100	260	10,4	913	182,5	402,2

approx. Coefficient of friction μ : Steel: 0,45 | PE: 0,25 | HDPE: 0,20



T-Profiles

T-profiles are ideal solutions for conveying of light goods and foodstuffs, whereas usually several T-profile belts are running side by side. The integrated V-guide on the running side prevents the profiles from running sideways and thus guarantees precise straight running. The BEHAbelt portfolio includes T-profiles in various geometries, PU-shore hardnesses and color combinations.

PU70A ultramarine blue smooth (9 x 4 mm)



approx. 76° Shore A

Recommended pretension 4...8 %

Order No.	Profile dimension mm	approx. weight kg/100m	Standard roll		Recommended min. pulley \varnothing		PT/DRIVE Fmax/belt Standard N	CONVEYANCE max. conveying weight Standard	
			m	ft	mm	inch		kg	lbs
FBTH9X4GL	9 x 4	2,8	70	230	25	1,0	20	4,0	8,9

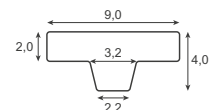

approx. Coefficient of friction μ : Steel: 0,75 | PE: 0,50 | HDPE: 0,45

PU65A ultramarine blue smooth (9,5 x 3,5 mm)



approx. 72° Shore A
Recommended pretension 4...8 %

Order No.	Profile dimension mm	approx. weight kg/100m	Standard roll		Recommended min. pulley \varnothing		PT/DRIVE Fmax/belt Standard N	CONVEYANCE max. conveying weight Standard	
			m	ft	mm	inch		kg	lbs
FBTG95X35LA	9,5 x 3,5	2,4	70	230	20	0,8	16	3,2	7,1

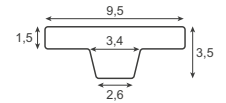

approx. Coefficient of friction μ : Steel: 0,75 | PE: 0,50 | HDPE: 0,45

PU80A ultramarine blue smooth (9,5 x 3,5 mm)



approx. 84° Shore A
Recommended pretension 4...8 %

Order No.	Profile dimension mm	approx. weight kg/100m	Standard roll		Recommended min. pulley \varnothing		PT/DRIVE Fmax/belt Standard N	CONVEYANCE max. conveying weight Standard	
			m	ft	mm	inch		kg	lbs
FBTJ95X35L	9,5 x 3,5	2,4	30	100	30	1,2	34	6,7	14,8

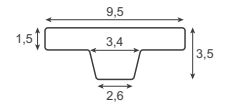

approx. Coefficient of friction μ : Steel: 0,65 | PE: 0,35 | HDPE: 0,30

PU85A ultramarine blue smooth (9,5 x 3,5 mm)



approx. 88° Shore A
Recommended pretension 3...6 %

Order No.	Profile dimension mm	approx. weight kg/100m	Standard roll		Recommended min. pulley \varnothing		PT/DRIVE Fmax/belt Standard N	CONVEYANCE max. conveying weight Standard	
			m	ft	mm	inch		kg	lbs
FBTK95X35L	9,5 x 3,5	2,4	30	100	50	2,0	28	5,5	12,2

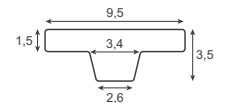

approx. Coefficient of friction μ : Steel: 0,65 | PE: 0,35 | HDPE: 0,30

PU80A ultramarine blue smooth (10 x 4,5 mm)



approx. 84° Shore A
Recommended pretension 4...8 %

Order No.	Profile dimension mm	approx. weight kg/100m	Standard roll		Recommended min. pulley \varnothing		PT/DRIVE Fmax/belt Standard N	CONVEYANCE max. conveying weight Standard	
			m	ft	mm	inch		kg	lbs
FBT12X45X10L	10 x 4,5	3,3	30	100	40	1,6	45	9,1	20,0



approx. Coefficient of friction μ : Steel: 0,65 | PE: 0,35 | HDPE: 0,30

PU60A **soft** ultramarine blue smooth (15 x 5 mm)



approx. 65° Shore A

Recommended pretension 4...8 %

Order No.	Profile dimension mm	approx. weight kg/100m	Standard roll		Recommended min. pulley Ø		PT/DRIVE Fmax/belt Standard N	CONVEYANCE max. conveying weight Standard	
			m	ft	mm	inch		kg	lbs
FBTF15X5LG	15 x 5	5,3	50	164	25	1,0	25	4,9	10,9

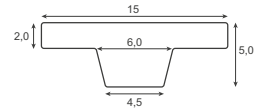

approx. Coefficient of friction μ : Steel: 0,90 | PE: 0,65 | HDPE: 0,60

PU65A ultramarine blue smooth (15 x 5 mm)



approx. 72° Shore A

Recommended pretension 4...8 %

Order No.	Profile dimension mm	approx. weight kg/100m	Standard roll		Recommended min. pulley Ø		PT/DRIVE Fmax/belt Standard N	CONVEYANCE max. conveying weight Standard	
			m	ft	mm	inch		kg	lbs
FBTG15X5LG	15 x 5	5,3	50	164	30	1,2	35	7,0	15,5

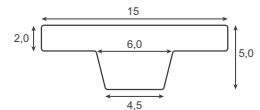

approx. Coefficient of friction μ : Steel: 0,75 | PE: 0,50 | HDPE: 0,45

PU80A ultramarine blue smooth (15 x 5 mm)



approx. 84° Shore A

Recommended pretension 4...8 %

Order No.	Profile dimension mm	approx. weight kg/100m	Standard roll		Recommended min. pulley Ø		PT/DRIVE Fmax/belt Standard N	CONVEYANCE max. conveying weight Standard	
			m	ft	mm	inch		kg	lbs
FBTJ15X5L	15 x 5	4,8	50	164	40	1,6	67	13,4	29,6

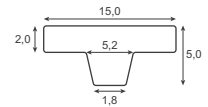

approx. Coefficient of friction μ : Steel: 0,65 | PE: 0,35 | HDPE: 0,30

PU75A sky blue smooth (8 x 5 mm)



approx. 80° Shore A

Recommended pretension 4...8 %

Order No.	Profile dimension mm	approx. weight kg/100m	Standard roll		Recommended min. pulley Ø		PT/DRIVE Fmax/belt Standard N	CONVEYANCE max. conveying weight Standard	
			m	ft	mm	inch		kg	lbs
FBSP75A8X5HI	8 x 5	3,1	40	131	30	1,2	30	6,0	13,2

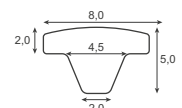

approx. Coefficient of friction μ : Steel: 0,70 | PE: 0,40 | HDPE: 0,35

3L T-Top PU80A orange smooth (14,3 x 7,5 mm)

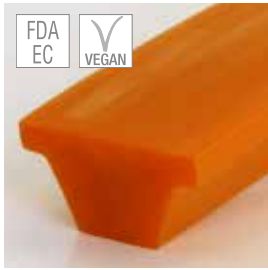

approx. 84° Shore A

Recommended pretension 3...6 %

Order No.	Profile dimension mm	approx. weight kg/100m	Standard roll		Recommended min. pulley Ø		PT/DRIVE Fmax/belt Standard N	CONVEYANCE max. conveying weight Standard	
			m	ft	mm	inch		kg	lbs
FBTJ142X750	14,3 x 7,5	8,7	30	100	80	3,1	91	18,1	40,0

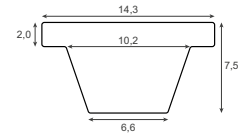

approx. Coefficient of friction μ : Steel: 0,65 | PE: 0,35 | HDPE: 0,30

Crown Top PU80A orange smooth (14,3 x 6,3 mm)



approx. 84° Shore A

Recommended pretension 3...6 %

Order No.	Profile dimension mm	approx. weight kg/100m	Standard roll		Recommended min. pulley Ø		PT/DRIVE Fmax/belt Standard N	CONVEYANCE max. conveying weight Standard	
			m	ft	mm	inch		kg	lbs
FBTJ143X630G	14,3 x 6,3	7,0	30	100	80	3,1	73	14,6	32,2

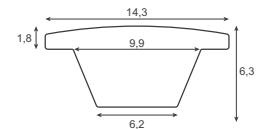

approx. Coefficient of friction μ : Steel: 0,65 | PE: 0,35 | HDPE: 0,30

PU80A half-round orange smooth (19,2 x 5,5 mm)



approx. 84° Shore A

Recommended pretension 3...6 %

Order No.	Profile dimension mm	approx. weight kg/100m	Standard roll		Recommended min. pulley Ø		PT/DRIVE Fmax/belt Standard N	CONVEYANCE max. conveying weight Standard	
			m	ft	mm	inch		kg	lbs
FBTJ192X550G	19,2 x 5,5	7,8	30	100	40	1,6	82	16,4	36,1

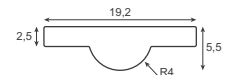

approx. Coefficient of friction μ : Steel: 0,65 | PE: 0,35 | HDPE: 0,30

PU80A half-round orange smooth (12,7 x 5,5 mm)



approx. 84° Shore A

Recommended pretension 3...6 %

Order No.	Profile dimension mm	approx. weight kg/100m	Standard roll		Recommended min. pulley Ø		PT/DRIVE Fmax/belt Standard N	CONVEYANCE max. conveying weight Standard	
			m	ft	mm	inch		kg	lbs
FBTJ127X550G	12,7 x 5,5	5,6	30	100	40	1,6	55	11,1	24,4

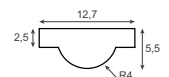

approx. Coefficient of friction μ : Steel: 0,65 | PE: 0,35 | HDPE: 0,30



T-Profiles for packaging industry

T-profiles are ideal for transporting various light goods and foodstuffs, with several T-profile belts usually running next to each other. The integrated guide wedge on the running side prevents the profiles from running sideways and thus guarantees precise straight running. The BEHbelt portfolio includes T-profiles in various geometries, PU shore hardnesses and colour combinations.

PU85A (25 x 5 mm) green or white embossed (EFI) / smooth

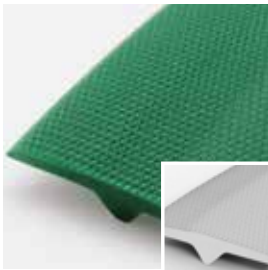

Order No.	Profile dimension	approx. weight	Standard roll		Recommended min. pulley Ø		PT/DRIVE Fmax/belt Standard N	CONVEYANCE max. conveying weight Standard	
			mm	kg/100m	m	ft		mm	inch
FBTK25X5GW01 (green, embossed)	25 x 5	7,0	50	164	50	2,0	90	18.1	39.9
FBSP85A25X5 (green, smooth)	25 x 5	7,0	50	164	50	2,0	90	18.1	39.9
FBTK25X5WW01 (white, embossed)	25 x 5	7,0	50	164	50	2,0	90	18.1	39.9
FBSP85A25X5A (white, smooth)	25 x 5	7,0	50	164	50	2,0	90	18.1	39.9

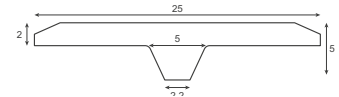

approx. 88° Shore A

Recommended pretension 3...6 %

approx. Coefficient of friction μ : Steel: 0,60 | PE: 0,35 | HDPE: 0,30

PU85A sapphire blue smooth / ribbed (LGD)* (25 x 5 mm)

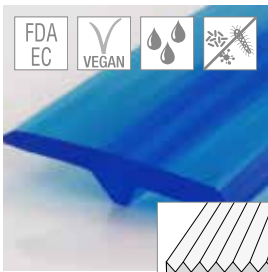

Order No.	Profile dimension	approx. weight	Standard roll		Recommended min. pulley Ø		PT/DRIVE Fmax/belt Standard N	CONVEYANCE max. conveying weight Standard	
			mm	kg/100m	m	ft		mm	inch
FBSP85A25X5B	25 x 5	7,3	50	164	50	2,0	80	16,0	35,3
FBTK25X5LGA (ribbed)	25 x 5	7,3	50	164	50	2,0	80	16,0	35,3

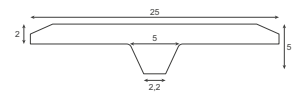

*Longitudinal grooves (LGD)

approx. 88° Shore A

Recommended pretension 3...6 %

approx. Coefficient of friction μ : Steel: 0,60 | PE: 0,35 | HDPE: 0,30

PU85A sapphire blue (20 x 8 mm)



Order No.	Profile dimension	approx. weight	Standard roll		Recommended min. pulley Ø		PT/DRIVE Fmax/belt Standard N	CONVEYANCE max. conveying weight Standard	
			mm	kg/100m	m	ft		mm	inch
FBSP85A20X8	20x8	10,0	30	100	100	4,0	115	22,9	50,6

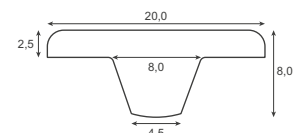

approx. 88° Shore A

Recommended pretension 3...6 %

approx. Coefficient of friction μ : Steel: 0,60 | PE: 0,35 | HDPE: 0,30

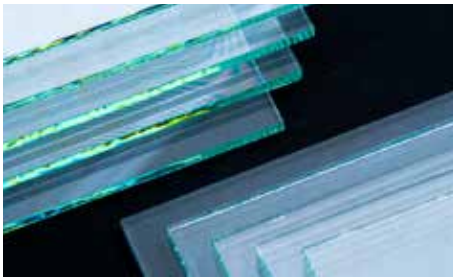

Glass industry

The special „Wing Top“ profile is ideal for the gentle transport of flat glass or similar sheet products.

Wing Top PU80A orange smooth

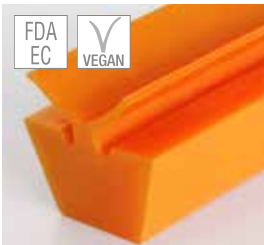

approx. 84° Shore A

Recommended pretension 3...6 %

Order No.	Profile dimension mm	approx. weight kg/100m	Standard roll		Recommended min. pulley Ø		PT/DRIVE Fmax/belt Standard N	CONVEYANCE max. conveying weight Standard	
			m	ft	mm	inch		kg	lbs
FBS117X100G	17 x 11 x 16,5	18,7	30	100	125	4,9	197	39,3	86,6

approx. Coefficient of friction μ : Steel: 0,65 | PE: 0,35 | HDPE: 0,30



Profiles for French fries / potato strips

Profiles to support the automatic elimination of defects in potato strips (French fries). Made of special hydrolysis resistant PU that ensures longer life and less bacterial growth in wet environment. The dirt-repellent material reduces discoloration and improves the visual appearance of the profiles.

High-quality PU ensures strong welding seams.

Channel Profile PU85A milky smooth

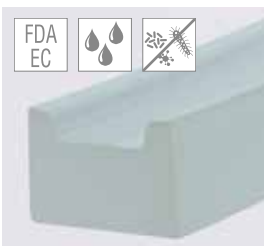

approx. 88° Shore A

Recommended pretension 3...6 %

Order No.	Profile dimension mm	approx. weight kg/100m	Standard roll ft	Recommended min. pulley Ø		PT/DRIVE Fmax/belt Standard N	CONVEYANCE max. conveying weight Standard	
				mm	inch		kg	lbs
FBSP85A180P1	18 x 11,8	20,0	1 x 30'5" / pc.	120	4,7	235	46,9	103,4
FBSP85A180P6	18 x 11,8	20,0	6 x 30'5" / pc.	120	4,7	235	46,9	103,4

approx. Coefficient of friction μ : Steel: 0,60 | PE: 0,35 | HDPE: 0,30

Square profile PU85A milky smooth

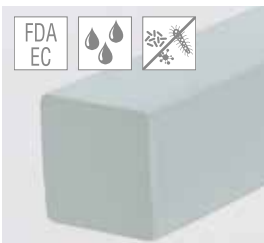

approx. 88° Shore A

Recommended pretension 3...6 %

Order No.	Profile dimension mm	approx. weight kg/100m	Standard roll ft	Recommended min. pulley Ø		PT/DRIVE Fmax/belt Standard N	CONVEYANCE max. conveying weight Standard	
				mm	inch		kg	lbs
FBSP85A118P1	11,8 x 11,8	16,7	1 x 30'5" / pc.	120	4,7	192	38,4	84,6
FBSP85A118P6	11,8 x 11,8	16,7	6 x 30'5" / pc.	120	4,7	192	38,4	84,6

approx. Coefficient of friction μ : Steel: 0,60 | PE: 0,35 | HDPE: 0,30



Spreading applications

In spreading applications, these profiles allow product strands to be pulled apart, e.g. in the confectionery industry. The dedicated selection of material and Shore hardness can improve the release properties of sticky products.

Special V-belt PU80A ultramarine blue (10 x 8 mm)



Order No.	Profile dimension	approx. weight	Standard roll		Recommended min. pulley Ø		PT/DRIVE Fmax/belt Standard N	CONVEYANCE max. conveying weight Standard	
	mm	kg/100m	m	ft	mm	inch		kg	lbs
FBKJ10X8BGA	10 x 8	6,9	100	328	80	3,1	73	14,6	32,2

approx. 84° Shore A

Recommended pretension 3...6 % approx. Coefficient of friction μ : Steel: 0,65 | PE: 0,35 | HDPE: 0,30

Twin V-belt PU95A beige



Order No.	Profile dimension	approx. weight	Standard roll		Recommended min. pulley Ø		PT/DRIVE Fmax/belt Standard N	CONVEYANCE max. conveying weight Standard	
	mm	kg/100m	m	ft	mm	inch		kg	lbs
FBSJ24X68BGB	24 x 6,8	15	30	100	100	3,9	315	63,0	138,9
FBSJ30X8BGB	30 x 8	22,4	50	164	120	4,7	420	84,0	185,2

approx. 95° Shore A

Recommended pretension 3...5 % approx. Coefficient of friction μ : Steel: 0,45 | PE: 0,25 | HDPE: 0,20

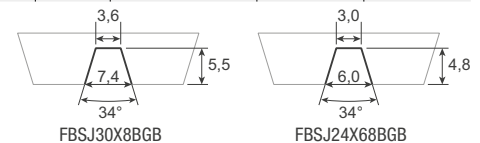

FBSJ30X8BGB

FBSJ24X68BGB

Further profiles available on request

PU80A, 3-ribbed



Order No.	FBSI17B0GR3 FBSI22C0GR3
Dimension	17 x 11 (B), 22 x 14 (C)
Hardness	approx. 84° Shore A
Color	orange

PU85A

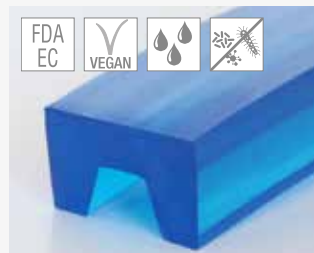

Order No.	FBSK15X10LG
Dimension	15 x 10 mm
Hardness	approx. 88° Shore A
Color	sapphire blue

PU95A

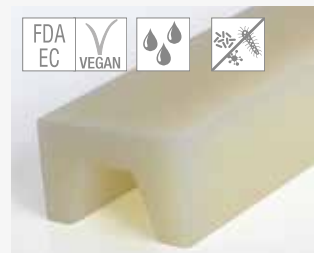

Order No.	FBSM12X8BG
Dimension	12 x 8 mm
Hardness	approx. 95° Shore A
Color	beige

PU85A



Order No.	FBKK10X8LGA
Dimension	10 x 8 mm
Hardness	approx. 88° Shore A
Color	ultramarine blue
Reinforced	Aramid



Profiles for fruit and vegetable sorting

Special profile for peeling machines. The central recess centres the conveyed material and transports it in the correct position for further processing.

Corn belt PU80A orange smooth without* / with serrations



Order No.	Profile dimension	approx. Weight	Standard roll		Recommended min. pulley Ø		PT/DRIVE Fmax/belt Standard N	CONVEYANCE max. conveying weight Standard	
	mm	kg/100m	m	ft	mm	inch		kg	lbs
FBSJ8X330G*	33 x 8	22,8	30	100	50	2,0	239	47,9	105,5
FBSJ8X330GA	33 x 8	22,8	30	100	50	2,0	239	47,9	105,5

● also available in a Shore 80 A sky blue

approx. 84° Shore A

Recommended pretension 3...6 %

approx. Coefficient of friction μ : Steel: 0,65 | PE: 0,35 | HDPE: 0,30

Further profiles available on request

Pear Profile



Order No.	FBSJ28X29WG
Dimension	28 x 29 mm
Hardness	approx. 84° Shore A
Color	white
Reinforced	Aramid

Round Belt



Order No.	FBZR85A095SA, FBZR85A095HA
Dimension	Ø 9,7 mm
Hardness	approx. 88° Shore A
Color	black, sky blue
Reinforced	Aramid

Twin T-Profile



Order No.	FBTI35X45LA
Dimension	35 x 4,5 mm
Hardness	approx. 80° Shore A
Color	sky blue
Surface structure	Longitudinal grooves

T-Profile

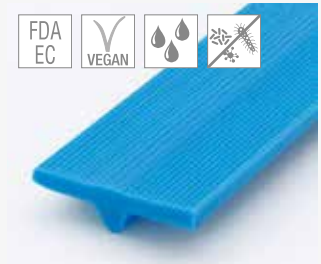

Order No.	FBTI175X45LA
Dimension	17,5 x 4,5 mm
Hardness	approx. 80° Shore A
Color	sky blue
Surface structure	Longitudinal grooves

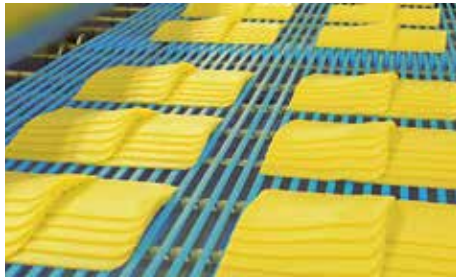

Slicer

For slicer applications and the downstream feeding lines BEHAbelt has different product options in its product range. Depending on the conveyed goods, extruded round belts, V-belts or T-profiles with special material properties and surface structures can be used.

V-belts with a curved surface are proven to be particularly suitable for Transport of sliced cheese proven.

PU75A ultramarine blue smooth with vaulted top

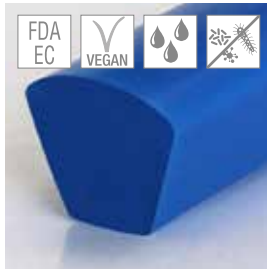

Order No.	Profile dimension	approx. weight	Standard roll		Recommended min. pulley \varnothing		PT/DRIVE Fmax/belt Standard N	CONVEYANCE max. conveying weight Standard	
			mm	kg/100m	m	ft		mm	inch
FBSP75A0865U	8 x 6,5 (M)	4,6	50	164	40	1,6	47	9,4	20,6

approx. 80° Shore A

Recommended pretension 4...8 %

approx. Coefficient of friction μ : Steel: 0,70 | PE: 0,40 | HDPE: 0,35

PU80A ultramarine blue smooth with vaulted top

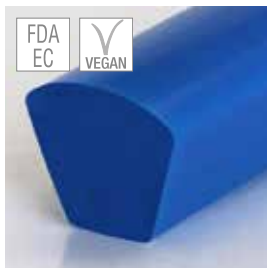

Order No.	Profile dimension	approx. weight	Standard roll		Recommended min. pulley \varnothing		PT/DRIVE Fmax/belt Standard N	CONVEYANCE max. conveying weight Standard	
			mm	kg/100m	m	ft		mm	inch
FBSP80A0865U	8 x 6,5 (M)	4,6	50	164	50	2,0	66	13,1	28,9

approx. 84° Shore A

Recommended pretension 4...8 %

approx. Coefficient of friction μ : Steel: 0,65 | PE: 0,35 | HDPE: 0,30

PU85A ultramarine blue smooth with vaulted top

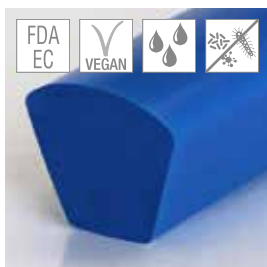

Order No.	Profile dimension	approx. weight	Standard roll		Recommended min. pulley \varnothing		PT/DRIVE Fmax/belt Standard N	CONVEYANCE max. conveying weight Standard	
			mm	kg/100m	m	ft		mm	inch
FBSP85A0865U	8 x 6,5 (M)	4,6	50	164	55	2,2	72	14,4	31,6

approx. 88° Shore A

Recommended pretension 4...8 %

approx. Coefficient of friction μ : Steel: 0,60 | PE: 0,30 | HDPE: 0,25



Building materials

For the transport of heavy and abrasive building materials our V-belts guarantee longevity and high wear resistance. In addition to the good temperature resistance, these belts, like all BEHAbelt products, can be quickly and easily welded and are available with or without tension members.

In addition we offer many coatings (see page 39) for different applications.

T-Profile PU95A beige smooth (30 x 9,5 mm)



Order No.	Profile dimension	approx. weight	Standard roll		Recommended min. pulley \varnothing		PT/DRIVE Fmax/belt Standard N	CONVEYANCE max. conveying weight Standard	
	mm	kg/100m	m	ft	mm	inch		kg	lbs
FBTM30X95B	30 x 9,5	14,8	30	100	110	4,3	309	61,9	136,3

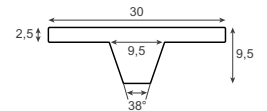

approx. 95° Shore A

Recommended pretension 3...5 %

approx. Coefficient of friction μ : Steel: 0,45 | PE: 0,25 | HDPE: 0,20

T-Profile PU95A beige smooth (50 x 11,5 mm)

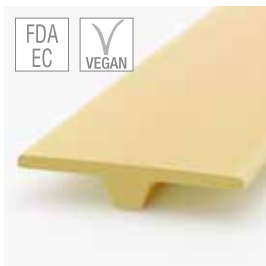

Order No.	Profile dimension	approx. weight	Standard roll		Recommended min. pulley \varnothing		PT/DRIVE Fmax/belt Standard N	CONVEYANCE max. conveying weight Standard	
	mm	kg/100m	m	ft	mm	inch		kg	lbs
FBTM50X11B	50 x 11,5	29,2	30	100	130	5,1	608	121,5	267,8

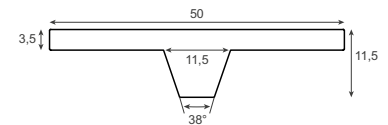

approx. 95° Shore A

Recommended pretension 3...5 %

Recommended pretension: 3...5 %, approx. Coefficient of friction μ : Steel: 0,45 | PE: 0,25 | HDPE: 0,20

V-belt additional height TPE55D beige smooth (22 x 16 mm)



Order No.	Profile dimension	approx. weight	Standard roll		Recommended min. pulley \varnothing		PT/DRIVE Fmax/belt Standard N	CONVEYANCE max. conveying weight Standard	
	mm	kg/100m	m	ft	mm	inch		kg	lbs
FBSR22X16BG	22 x 16	37	50	164	280	11,0	1498	299,5	660,1

55° Shore D · approx. 100° Shore A

Recommended pretension 2...4 %

approx. Coefficient of friction μ : Steel: 0,35 | PE: 0,20 | HDPE: 0,15



Intralogistics – Roller conveyors

These special profiles have optimised material properties for reliable use in roller conveyors, whether as tangential drive, roller-to-roller drive or crossed drive.

Please also look at our round belt range page 14 and following.

PU75A plus orange



Order No.	Description	Profile dimension	approx. weight	Standard roll		Recommended min. pulley \varnothing		PT/DRIVE Fmax/belt Standard N	CONVEYANCE max. conveying weight, Standard	
				mm	kg/100m	m	ft		mm	inch
FBPVPJ20	PJ2	4,8 x 4	1,96	200	656	30	1,2	14	2,9	6,3
FBPVPJ30	PJ3	7 x 4	2,93	200	656	30	1,2	22	4,3	9,5
FBPVPJ40	PJ4	9,3 x 4	3,92	200	656	30	1,2	29	5,8	12,7

approx. 80° Shore A

Recommended pretension 3...6 %

approx. Coefficient of friction μ : Steel: 0,70 | PE: 0,40 | HDPE: 0,35

PU85A plus ultramarine blue



Order No.	Description	Profile dimension	approx. weight	Standard roll		Recommended min. pulley \varnothing		PT/DRIVE Fmax/belt Standard N	CONVEYANCE max. conveying weight, Standard	
				mm	kg/100m	m	ft		mm	inch
FBPVKPJ2L	PJ2	4,8 x 4	1,96	200	656	40	1,6	31	6,1	13,5
FBPVKPJ3L	PJ3	7 x 4	2,93	200	656	40	1,6	46	9,2	20,3
FBPVKPJ4L	PJ4	9,3 x 4	3,92	200	656	40	1,6	61	12,3	27,1

approx. 88° Shore A

Recommended pretension 3...6 %

approx. Coefficient of friction μ : Steel: 0,60 | PE: 0,30 | HDPE: 0,25

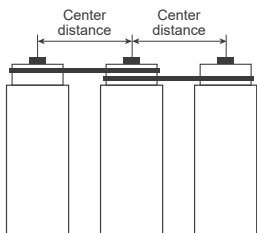

PU to rubber Poly V-belt conversion

Centre distance for pulley \varnothing 43 mm	Fabrication length BEHAbelt*	PJ2	PJ3	PJ4
		nominal length specification		
53 - 56	234	Ref. 2PJ246-43	Ref. 3PJ246-43	Ref. 4PJ246-43
60 - 63	243	Ref. 2PJ256-43	Ref. 3PJ256-43	Ref. 4PJ256-43
64 - 65	252	Ref. 2PJ265-43	Ref. 3PJ265-43	Ref. 4PJ265-43
66 - 67	257	Ref. 2PJ270-43	Ref. 3PJ270-43	Ref. 4PJ270-43
71 - 72	268	Ref. 2PJ282-43	Ref. 3PJ282-43	Ref. 4PJ282-43
73 - 75	272	Ref. 2PJ286-43	Ref. 3PJ286-43	Ref. 4PJ286-43
76 - 77	276	Ref. 2PJ290-43	Ref. 3PJ290-43	Ref. 4PJ290-43
78 - 79	274	Ref. 2PJ288-43	Ref. 3PJ288-43	Ref. 4PJ288-43
80 - 84	287	Ref. 2PJ302-43	Ref. 3PJ302-43	Ref. 4PJ302-43
87 - 91	298	Ref. 2PJ314-43	Ref. 3PJ314-43	Ref. 4PJ314-43
92 - 95	300	Ref. 2PJ316-43	Ref. 3PJ316-43	Ref. 4PJ316-43
97 - 101	319	Ref. 2PJ336-43	Ref. 3PJ336-43	Ref. 4PJ336-43
103 - 107	329	Ref. 2PJ346-43	Ref. 3PJ346-43	Ref. 4PJ346-43
115 - 118	353	Ref. 2PJ372-43	Ref. 3PJ372-43	Ref. 4PJ372-43
119 - 121	357	Ref. 2PJ376-43	Ref. 3PJ376-43	Ref. 4PJ376-43
123 - 128	369	Ref. 2PJ388-43	Ref. 3PJ388-43	Ref. 4PJ388-43

* general pretension of 5% to the nominal length specification

bluepower TPE55D smooth

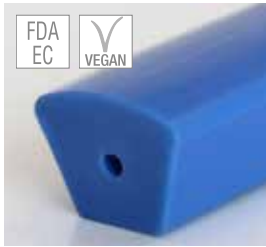

55° Shore D - approx. 100° Shore A

Recommended pretension 2...4 %

Order No.	Profile dimension mm	approx. weight kg/100m	Standard roll		Recommended min. pulley \varnothing		PT/DRIVE Fmax/belt Standard N	CONVEYANCE max. conveying weight Standard	
			m	ft	mm	inch		kg	lbs
FBKBLP17113W	16,35 x 11,3	18,0	50	164	175	7,0	715	143,0	315,3
FBKBLP1711W2	16,35 x 11,3	18,0	100	328	175	7,0	715	143,0	315,3

approx. Coefficient of friction μ : Steel: 0,35 | PE: 0,20 | HDPE: 0,15

TPE55D beige smooth with chamfer



55° Shore D - approx. 100° Shore A

Recommended pretension 2...4 %

Order No.	Profile dimension mm	approx. weight kg/100m	Standard roll		Recommended min. pulley \varnothing		PT/DRIVE Fmax/belt Standard N	CONVEYANCE max. conveying weight Standard	
			m	ft	mm	inch		kg	lbs
FBKH55D17115	17 x 11,4	18,0	100	328	175	7,0	696	139,2	306,8

approx. Coefficient of friction μ : Steel: 0,35 | PE: 0,20 | HDPE: 0,15

Double V-belt PU85A black (17 x 13,5 mm)



approx. 88° Shore A

Recommended pretension 3...6 %

Order No.	Profile dimension mm	approx. weight kg/100m	Standard roll		Recommended min. pulley \varnothing		PT/DRIVE Fmax/belt Standard N	CONVEYANCE max. conveying weight Standard	
			m	ft	mm	inch		kg	lbs
FBSK17X13SG	17 x 13,5	2,3	50	164	160	6,3	288	57,6	127,0

approx. Coefficient of friction μ : Steel: 0,60 | PE: 0,30 | HDPE: 0,25

Further profiles available on request

TPE55D



Order No.	FBKBLP1711W3
Dimension	16,35 x 11,3 mm
Hardness	approx. 55° Shore D 100° Shore A
Color	blue

TPE55D



Order No.	FBKS17115BGA
Dimension	17 x 11,4 mm
Hardness	approx. 55° Shore D 100° Shore A
Color	beige

PU80A



Order No.	FBSJ17X13SG
Dimension	17 x 13,5 mm
Hardness	approx. 84° Shore A
Color	black

Didn't find your belt?



No Minimum Order Quantities

According to Your Specifications

In Only 4-8 Weeks

BEHAbelt offers you the exclusive and fast delivery of your desired profile or conveyor belt!

If a standard profile does not meet the requirements of your application, BEHAbelt offers you the unique opportunity to develop a customer-specific product. According to your specifications and your design!

Tell us about your application!

Thanks to our modern in-house tool shop, we are able to produce special profiles for you in the shortest possible time. On page 136 you will find the technical inquiry template; it helps to gather the most important information to fulfil your request.

FAST DELIVERY (4-8 WEEKS)

- Many years of experience, in-house manufacturing of tooling, individual consulting
- Development of customised profiles and conveyor belts
- Designed specifically for your application
- According to your design

ECONOMIC ADVANTAGES

- Exclusivity / securing the After Sales Market
- Material combination
- Optimization of your application through the perfect profile
- Improved service life and functionality
- Appropriate welding technology

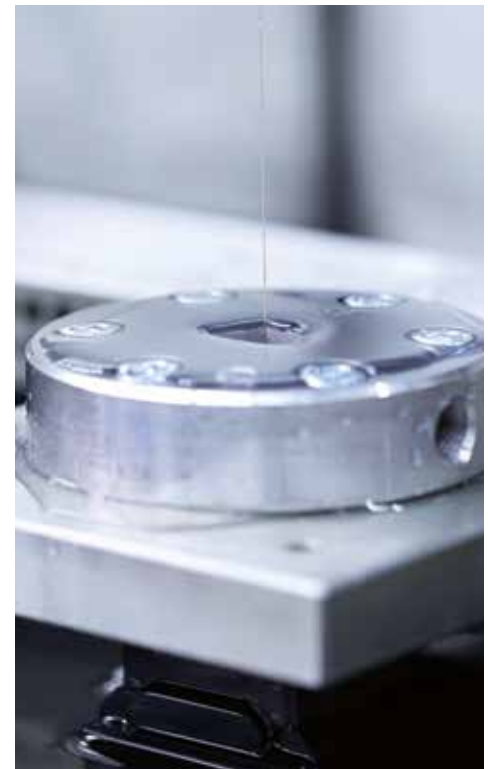

CONVEYOR

BELTS

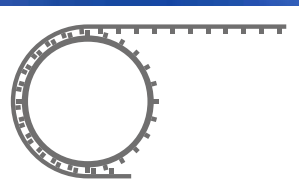

Slip-free (p. 63)

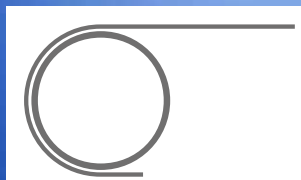

Friction driven (p. 64)

ELASTIC MONOLITHIC CONVEYOR BELTS

Applications, Industries, Product features	58
Overview belt structures.....	61
Table structure key	62
Slip-free conveyor belts	63
Conveyor belts up to 730 mm.....	64
Conveyor belts for intralogistics.....	69
Machine tapes.....	70
Elastic conveyor belts up to 140 mm	71
Welding electrodes.....	95

Elastic monolithic conveyor belts

BEHAbelt offers innovative and quality solutions. There is already a huge variety of belting categories and design variations available on the market. However, the increasing automation of industrial production processes and machines requires ongoing evolution. Only if all components and their features keep pace, real improvements in terms of efficiency, capacity and safety can be achieved.

This is where the new elastic monolithic conveyor belts by BEHAbelt deliver an important contribution. These products enable longer life and minimize risks like cover and ply delamination or edge fraying versus conventional coated conveyor belts with fabric carcasses.

BEHAbelt offers both friction and positive driven conveyor belts for your applications.



Advantages

PRODUCT DESIGN

- No risk of contamination based on exposed belt fabrics or due to mechanical damage to belt edges
- Hygiene and support for your HACCP concept.
- Excellent cleanability, hydrolysis-resistant and microbial-resistant.
- Additional features; e.g. metal and X-ray detectable, UV-C resistant, antistatic discharge.
- Reduced energy consumption due to high longitudinal flexibility and thus also gentle motor and shaft loading.
- Very good belt tracking in under-square applications.

HANDLING

- Easy installation of elastic belt versions due to elasticity.
- Softer belts allow even a hand mounted possibility with fixed centre to centre machinery designs without any take up.
- Butt-end weldings can be made with user-friendly tool, which ensures no loss of surface structure, homogeneity and elasticity in the joining
- Accessories such as corrugated sidewalls, cleats, V-guides and other profiles can be welded on excellently.

Industries and applications

Elastic monolithic conveyor belts are especially beneficial for the various applications to convey unwrapped foodstuff. Furthermore, this design and the special features are opening up interesting opportunities way beyond that, for example in:

INDUSTRIES

- Food (Fish, Meat, Poultry, Fruit & Vegetable, Confectionery and Bakery)
- Packaging (Food and Non-Food)
- Pharmacy
- Logistics and Material Handling

APPLICATIONS

- General conveying, Separation and Acceleration
- Weighing, Sorting, Portioning
- Feeding, Cutting, Detecting (metal detectors) and many more

Metal & X-Ray detectable PU80 SAFE

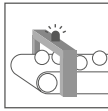

Product contamination with foreign objects, e.g. synthetic particles, is a high risk in food processing.

Metal or X-ray detectors can be used to detect contamination of the food by foreign particles.

Both the elastic monolithic belts and the non-reinforced belt profiles are suitable for trouble-free transport through the inspection area of metal and X-ray detectors. Thanks to the homogeneous design, the measurement results of the detectors are neither distorted nor influenced.

For upstream process sections, the PU80Asafe product series offers the possibility to detect and remove inadvertently inserted strip pieces downstream with a detector. This product series thus makes a preventive contribution to product safety.

2 Components design



Various transport tasks can be optimised by 2-component conveyor belts can be optimised.

Depending on the material to be conveyed or the type of conveyor (e.g. accumulation, inclined conveyor), a wide variety of belt types are required. The 2C process allows both structures to be combined and 2 different degrees of hardness to be combined in one belt.

For example, when designing a belt for an inclined conveyor, the transport side can have more grip, but the running side can have good gliding properties.

MICROclean Surface finish

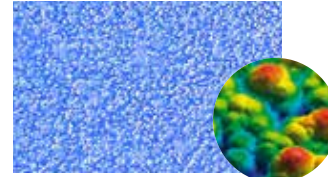

BEHAbelt uses a unique structure finish for the special requirements of the food industry.

The special structure of the MICROclean surface allows better and faster cleaning of the belt surface due to the special surface design, which can only be recognised with a magnifying glass. In addition, the transported products are easier to remove, especially when transferring the product to the next transport section.

The graphic illustrates the principle of MICROclean:

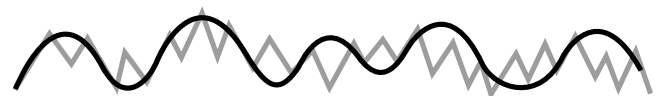

— Belt surface smooth gloss (SG)

— Belt surface MICROclean smooth matt (SM)

Slip-free / Friction driven

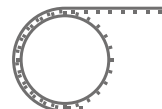

Slip-free AT5 elastic conveyor belts

The positive-driven AT5 conveyor belts from BEHAbelt enable slip-free traction, even with the smallest pulley diameters of only Ø 15 mm. The low pretension of only 2% for PU80A and 1% for PU95A enables easy installation and also reduces the bearing load and heat development in rolling nose bar (usually made of plastic).

Friction driven elastic conveyor belts and machine tapes

These conveyor belts are installed in the system with a pretension of 0.5-5%. The precise pretension ensures optimum power transmission and thus optimises the bearing load and ultimately your energy costs. The belts are guided e.g. via crowned pulleys or welded-on V-guides.

Suitable belt designs for your applications

We aim to understand the challenges and applications of our customers and to provide support through our enhanced product portfolio and know-how. The variety of options to combine surface structures, material features and colors of monolithic conveyor belts, offered by BEHAbelt, are unmatched in the market.

Surface structures

There are currently twelve different surfaces available, which can be combined with each other in almost any way on the transport and running side. Five of these surfaces (nub top, diamond, smooth matt as well as longitudinal and transversal grooves) are also available with the unique „MICROclean“ surface finish.

Material properties

BEHAbelt conveyor belts also offer very useful special properties that make them suitable for even the most demanding conveyor belt applications.



FDA/EC conformity for direct contact with food. (see also p. 123)



Metal and X-ray detectable conveyor belts for maximum food safety. These products are part of the PU SAFE range.



Hydrolysis resistant conveyor belts for optimal performance in warm, wet and humid environment



Specially protected against UV-C waves.



Friction driven conveyor belts for roller conveyors.



Exclusive use of raw materials from non-animal sources.



Antistatic conveyor belts to ensure electrical discharge in sensitive applications.



Microbe-resistant materials do not provide a breeding ground for microorganisms.



Unique surface finish that offers optimal release properties and best cleanability due to its rounded structure.



The 2-component production allows the combination of different material hardnesses, properties and colors.

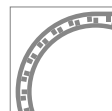

Slip-free conveyor belts for positive drives.



Flame-retardant conveyor belt in accordance with ISO 340 and ASTM D378 standards.

Hardness

BEHAbelt distinguish between two hardness ranges.

SOFT	PU65A, PU75A, PU80A
HARD	PU95A/55D, TPE55D/63D

Thickness

Conveyor belts are available in different thicknesses from 0,9 - 4 mm.

0,9 mm	2 mm
1 mm	2,5 mm
1,2 mm	3 mm
1,6 mm	4 mm

OVERVIEW BELT SURFACES

The belt surfaces shown here can be combined almost arbitrarily. In addition, you have the option of individual coloring and dedicated product properties, such as UV-C resistance or antistatic conductivity.

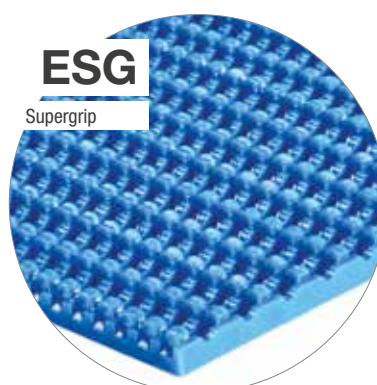
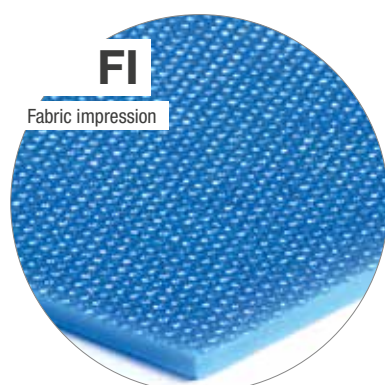
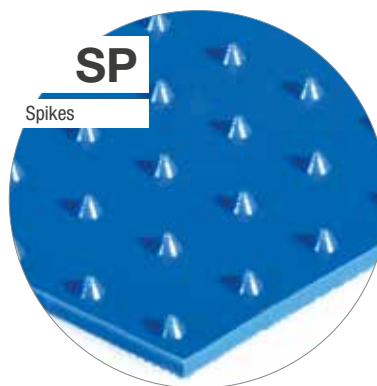
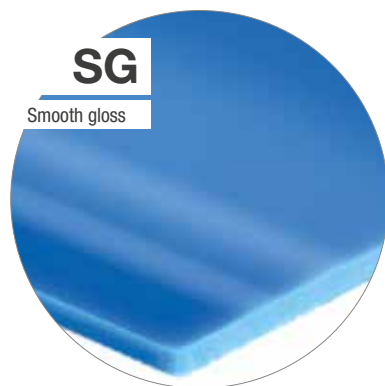
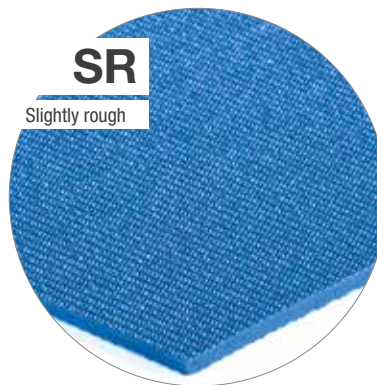
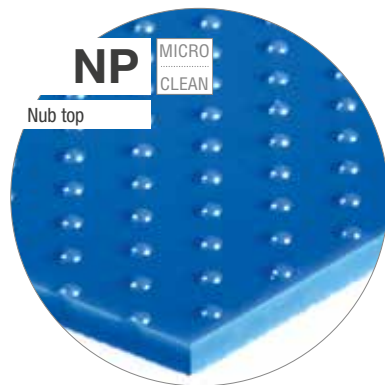
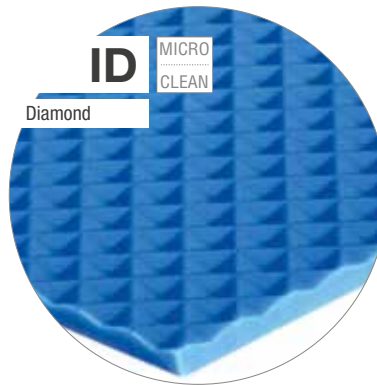

Table structure key

General explanation of the product tables











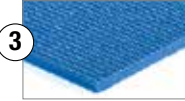











		TOP SIDE: SLIGHTLY ROUGH (SR)														
																Order No.
Diamond (ID)	UB	MICRO CLEAN	PU80A	84 A	1,0	0,039	10	0,40	0,24	1,32	0,20	1,12	50	164	1-5%	FBFJ750X10LK

Table structure key

- ① Structure of the bottom side; shown as image and text
- ② Symbol for product properties of the bottom side (see table below for symbol explanation)
- ③ Structure of the **transport side**; shown as image and text
- ④ Belt color (original colour may vary; standard colours: ultramarine blue, sky blue, white and black)
- ⑤ Symbol for product properties of the **transport side** (see table below for symbol explanation)
- ⑥ Specification of BEHAbelt material type quality
- ⑦ Material hardness in Shore A/D
- ⑧ Belt thickness in mm/inch
- ⑨ Recommended minimum pulley diameter (mm). Smaller pulley diameters shorten the service life of the belt
- ⑩ k1% static – Modulus of elasticity per mm belt width when tensioning the belt (max. load bearing capacity)
- ⑪ k1% relaxed – Modulus of elasticity per mm belt width after the belt has run in (max. transport weight)
- ⑫ Standard roll size (standard delivery form)
- ⑬ Recommended pretension* of the belt in the system (in %). Higher pretension increases the axle and bearing loads.

*Calculation formulas and useful information starting on page 131

Symbols

									
Antistatic profile with excellent mechanical properties.	Particularly cold-resistant profile down to -30°C.	MICROclean surface finish for optimum release properties and easy cleaning.	Particularly good UV protection.	Profiles with FDA/EC conformity for direct contact with food.	Use of raw materials from non-animal sources.	Metal and X-ray detectable profiles for maximum food safety.	Hydrolysis resistance (HY). Suitable for humid environments.	Microbe-resistant materials do not provide a breeding ground for microorganisms.	2-component belt enables combination of hardness and properties.

Color codes

UB ultramarine blue	CB capri blue	HI sky blue	SW black	TR transparent	WE white
----------------------------	----------------------	--------------------	-----------------	-----------------------	-----------------



AT5 – slip-free conveyor belts

The positive-driven AT5 conveyor belts enable slip-free traction, even with the smallest pulley diameters of only Ø 15 mm. This means that even conveyor sections with the smallest transfers can now be utilized with a slip-free belt solution.

Thanks to the careful selection of raw materials for direct food contact, the belt solutions offer very good microbial, hydrolysis and chemical resistance.

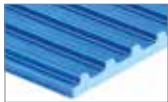

BOTTOM SIDE: AT5 // 700 mm







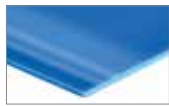



Top side	Color	Additional features	Quality	Hardness Shore	Profile thickness		Recommended min. pulley Ø*		k1% static		k1% relaxed		Standard roll		Recommended pretension	Order No.
					mm	inch	mm	inch	N/mm	lbs/inch	N/mm	lbs/inch	m	ft		
Slightly rough (SR)	UB		PU80A	84 A	2,2	0,09	15	0,59	0,39	2,2	0,27	1,50	50	164	2%	FBFJ750X22LP
			PU95A	95 A	2,2	0,09	22	0,79	0,57	3,22	0,40	2,26	50	164	1%	FBFM750X22LA
		2K	PU65A PU80A	72 A 84 A	3,0	0,118	18	0,7	0,50	2,90	0,35	2,00	50	164	2%	FBFJG750X3LE
Smooth matt (SM)	UB	MICRO CLEAN 2K	PU65A PU80A	72 A 84 A	3,0	0,118	18	0,7	0,50	2,90	0,35	2,00	50	164	2%	FBFJG750X3L
			PU65A PU95A	72 A 95 A	3,0	0,118	28	1,1	0,68	3,90	0,48	2,70	50	164	1%	FBFMG750X3L
Transversal grooves (TGA)	UB	MICRO CLEAN 2K	PU65A PU80A	72 A 84 A	3,8	0,149	28	1,1	0,50	2,90	0,35	2,00	50	164	2%	FBFJG750X38A
Nub top (NP)	UB	MICRO CLEAN 2K	PU65A PU80A	72 A 84 A	3,2	0,125	25	1,0	0,50	2,90	0,35	2,00	50	164	2%	FBFJG750X3LC
Diamond (ID)	UB	MICRO CLEAN 2K	PU65A PU80A	72 A 84 A	3,0	0,118	18	0,7	0,47	2,70	0,33	1,90	50	164	2%	FBFJG750X3LD
			PU65A PU95A	72 A 95 A	3,2	0,125	28	1,1	0,68	3,90	0,48	2,70	50	164	1%	FBFMG750X32L
Spikes (SP)	UB	2K	PU65A PU80A	72 A 84 A	3,0	0,118	25	1,0	0,50	2,90	0,35	2,00	50	164	2%	FBFJG750X3LB
			PU95A	95 A	3,0	0,118	38	1,5	1,0	5,80	0,70	4,06	50	164	1%	FBFM750X3LE

* recommended pulley design: AT5 (optionally also T5 possible)

Elastic conveyor belts up to 730 mm



TOP SIDE: SMOOTH GLOSS (SG)

Bottom side	Color	Additional features	Quality	Hardness Shore	Profile thickness		Recommended min. pulley \varnothing		k1% static		k1% relaxed		Standard roll		Recommended pretension	Order No.
					mm	inch	mm	inch	N/mm	lbs/inch	N/mm	lbs/inch	m	ft		
 Fabric impression (FI)	UB		PU65A	72 A	2,0	0,078	12	0,50	0,29	1,60	0,20	1,10	50	164	1-5%	FBFG750X20LA
					1,6	0,062	15	0,60	0,34	2,00	0,24	1,40	50	164	1-5%	FBFI750X16LD
			PU75A	80 A	2,0	0,078	20	0,80	0,43	2,40	0,30	1,70	50	164	1-5%	FBFI750X20LB
					3,0	0,118	30	1,18	0,64	3,70	0,45	2,60	50	164	1-5%	FBFI750X30LG
 Smooth gloss (SG)	UB		PU95A	95 A	2,0	0,078	35	1,40	1,03	5,90	0,72	4,10	50	164	0,5-3%	FBFL750X20LC
					3,0	0,118	50	2,00	1,54	8,80	1,08	6,20	50	164	0,5-3%	FBFL750X30LC
 Smooth gloss (SG)	HI		PU95A	95 A	2,0	0,078	35	1,40	1,03	5,90	0,72	4,10	50	164	0,5-3%	FBFL750X20LG
					3,0	0,118	50	2,00	1,54	8,80	1,08	6,20	50	164	0,5-3%	FBFL750X30LG
 Diamond (ID)	UB		PU80A	84 A	1,8	0,070	18	0,71	0,51	2,90	0,36	2,00	50	164	1-5%	FBFJ750X18LK
					2,0	0,078	20	0,80	0,57	3,30	0,40	2,30	50	164	1-5%	FBFJ750X2LA
			PU95A	95 A	2,0	0,078	35	1,40	0,98	5,60	0,68	3,90	50	164	0,5-3%	FBFM750X2LC
					3,0	0,118	50	2,00	1,47	8,40	1,03	5,90	50	164	0,5-3%	FBFM750X3LC
 Diamond (ID)	HI		PU95A	95 A	2,0	0,078	35	1,40	0,98	5,60	0,68	3,90	50	164	0,5-3%	FBFM750X2LD
					3,0	0,118	50	2,00	1,47	8,40	1,03	5,90	50	164	0,5-3%	FBFM750X3LD
 Slightly rough (SR)	TR		PU80A	84 A	1,6	0,062	15	0,60	0,48	2,70	0,34	1,90	50	164	1-5%	FBFJ750X16T

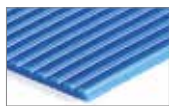





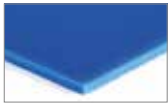





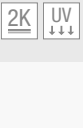



TOP SIDE: LONGITUDINAL GROOVES (LGB)

Bottom side	Color	Additional features	Quality	Hardness Shore	Profile thickness		Recommended min. pulley \varnothing		k1% static		k1% relaxed		Standard roll		Recommended pretension	Order No.
					mm	inch	mm	inch	N/mm	lbs/inch	N/mm	lbs/inch	m	ft		
 Fabric impression (FI)	UB		PU80A	84 A	1,6	0,062	15	0,60	0,48	2,70	0,34	1,90	50	164	1-5%	FBFJ750X16LK



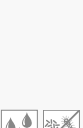

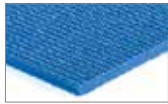

TOP SIDE: SMOOTH MATT (SM)

Bottom side	Color	Additional features	Quality	Hardness Shore	Profile thickness		Recommended min. pulley Ø		k1% static		k1% relaxed		Standard roll		Recommended pretension	Order No.												
					mm	inch	mm	inch	N/mm	lbs/inch	N/mm	lbs/inch	m	ft														
 Diamond (ID)	UB		PU65A	72 A	1,8	0,070	12	0,50	0,32	1,80	0,22	1,30	50	164	1-5%	FBFGI750X18L												
			PU75A	80 A																								
 Fabric impression (FI)	UB		PU75A	80 A	1,0	0,039	10	0,40	0,21	1,20	0,15	0,90	50	164	1-5%	FBFI750X10LA												
																	1,6	0,062	15	0,60	0,34	2,00	0,24	1,40	50	164	1-5%	FBFI750X16LA
 Fabric impression (FI)	UB		PU75A	80 A	1,0	0,039	10	0,40	0,21	1,20	0,15	0,90	50	164	1-5%	FBFI750X10WA												
																	2,0	0,078	20	0,80	0,43	2,40	0,30	1,70	50	164	1-5%	FBFI750X20WA
																	2,0	0,078	20	0,80	0,43	2,40	0,30	1,70	50	164	1-5%	FBFI750X20LA
 Fabric impression (FI)	WE		PU75A	80 A	1,0	0,039	10	0,40	0,21	1,20	0,15	0,90	50	164	1-5%	FBFI750X10WA												
																	2,0	0,078	20	0,80	0,43	2,40	0,30	1,70	50	164	1-5%	FBFI750X20WA
																	2,0	0,078	20	0,80	0,43	2,40	0,30	1,70	50	164	1-5%	FBFI750X20LA
 Fabric impression (FI)	UB		PU80A	84 A	1,0	0,039	10	0,40	0,30	1,70	0,21	1,20	50	164	1-5%	FBFJ750X1LE												
																	1,0	0,039	10	0,40	0,30	1,70	0,21	1,20	50	164	1-5%	FBFJ750X1LD
																	1,6	0,062	15	0,60	0,48	2,70	0,34	1,90	50	164	1-5%	FBFJ750X16LD
																	2,0	0,078	20	0,80	0,60	3,40	0,42	2,40	50	164	1-5%	FBFJ750X20LD
 Fabric impression (FI)	CB		PU80A SAFE	84 A	1,0	0,039	10	0,40	0,30	1,70	0,21	1,20	50	164	1-5%	FBFJ750X1LA												
																	1,6	0,062	15	0,60	0,48	2,70	0,34	1,90	50	164	1-5%	FBFJ750X16LE
																	2,0	0,078	20	0,80	0,60	3,40	0,42	2,40	50	164	1-5%	FBFJ750X20LE
																	3,0	0,118	30	1,20	0,90	5,10	0,63	3,60	50	164	1-5%	FBFJ750X30LE
 Fabric impression (FI)	UB		PU95A	95 A	1,0	0,039	18	0,71	0,51	2,90	0,36	2,10	50	164	0,5-3%	FBFL750X10LA												
																	1,6	0,062	25	1,00	0,82	4,70	0,58	3,30	50	164	0,5-3%	FBFL750X16LA
																	2,0	0,078	35	1,40	1,03	5,90	0,72	4,10	50	164	0,5-3%	FBFL750X20LA
																	3,0	0,118	50	2,00	1,54	8,80	1,08	6,20	50	164	0,5-3%	FBFL750X30LA
																	4,0	0,157	75	3,00	2,06	11,70	1,44	8,20	30	100	0,5-3%	FBFL750X40LA
 Fabric impression (FI)	WE		PU95A	95 A	1,6	0,062	25	1,00	0,82	4,70	0,58	3,30	50	164	0,5-3%	FBFL750X16WA												
																	2,0	0,078	35	1,40	1,03	5,90	0,72	4,10	50	164	0,5-3%	FBFL750X20WA
																	3,0	0,118	50	2,00	1,54	8,80	1,08	6,20	50	164	0,5-3%	FBFL750X30WA

Elastic conveyor belts up to 730 mm







TOP SIDE: SLIGHTLY ROUGH (SR)

Bottom side	Color	Additional features	Quality	Hardness Shore	Profile thickness		Recommended min. pulley \varnothing		k1% static		k1% relaxed		Standard roll		Recommended pretension	Order No.												
					mm	inch	mm	inch	N/mm	lbs/inch	N/mm	lbs/inch	m	ft														
 Diamond (ID)	UB		PU75A	80 A	1,6	0,062	13	0,52	0,33	1,9	0,23	1,30	50	164	1-5%	FBFJ750X16LI												
																	1,0	0,039	10	0,40	0,29	1,60	0,20	1,10	50	164	1-5%	FBFJ750X10LK
																	1,2	0,047	12	0,47	0,34	2,00	0,24	1,40	50	164	1-5%	FBFJ750X12LJ
1,8	0,070	18	0,71	0,51	2,90	0,36	2,00	50	164	1-5%	FBFJ750X18LJ																	
 Fabric impression (FI)	UB		PU80A	84 A		1,0	0,039	10	0,40	0,30	1,70	0,21	1,20	50	164	1-5%	FBFJ750X10L											
						1,2	0,047	10	0,40	0,36	2,10	0,25	1,40	50	164	1-5%	FBFJ750X12L											
						1,6	0,062	15	0,60	0,48	2,70	0,34	1,90	50	164	1-5%	FBFJ750X16L											
						2,0	0,078	20	0,80	0,60	3,40	0,42	2,40	50	164	1-5%	FBFJ750X20L											
						0,9	0,035	8	0,31	0,24	1,40	0,17	1,00	50	164	1-5%	FBFJ750X09LA											
																		1,2	0,047	10	0,40	0,33	1,90	0,23	1,30	50	164	1-5%
1,6	0,062	15	0,60	0,43	2,50	0,30	1,70	50	164	1-5%	FBFJ750X16LA																	



TOP SIDE: SPIKES (SP)

Bottom side	Color	Additional features	Quality	Hardness Shore	Profile thickness		Recommended min. pulley \varnothing		k1% static		k1% relaxed		Standard roll		Recommended pretension	Order No.
					mm	inch	mm	inch	N/mm	lbs/inch	N/mm	lbs/inch	m	ft		
 Diamond (ID)	UB		PU80	84 A	2,0	0,078	20	0,80	0,57	3,30	0,40	2,30	50	164	1-5%	FBFJ750X20LI
 Fabric impression (FI)	UB		PU80A	84 A	1,2	0,047	12	0,47	0,36	2,10	0,25	1,40	50	164	1-5%	FBFJ750X12LG
					2,0	0,078	25	1,00	0,60	3,40	0,42	2,40	50	164	1-5%	FBFJ750X2LG
					2,0	0,078	40	1,57	1,03	5,90	0,72	4,10	50	164	0,5-3%	FBFM750X2LA
					2,5	0,098	45	1,80	1,29	7,30	0,90	5,10	50	164	0,5-3%	FBFM750X25LD
3,0	0,118	55	2,20	1,54												

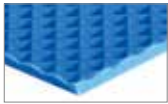

TOP SIDE: DIAMOND (ID)

Bottom side	Color	Additional features	Quality	Hardness Shore	Profile thickness		Recommended min. pulley \varnothing		k1% static		k1% relaxed		Standard roll		Recommended pretension	Order No.																								
					mm	inch	mm	inch	N/mm	lbs/inch	N/mm	lbs/inch	m	ft																										
Diamond (ID)	UB		PU65A	72 A	2,2	0,086	15	0,60	0,28	1,60	0,20	1,10	50	164	1-5%	FBFG750X22L																								
																	MICRO CLEAN	PU80A	84 A	2,2	0,086	22	0,87	0,60	3,40	0,42	2,40	50	164	1-5%	FBFJ750X22L0									
																																	PU65A PU80A	72 A 84 A	2,2	0,086	18	0,71	0,44	2,50
Slightly rough (SR)	UB		PU80A	84 A	1,2	0,047	12	0,47	0,34	2,00	0,24	1,40	50	164	1-5%	FBFJ750X12LJ																								
																		1,8	0,070	18	0,71	0,51	2,90	0,36	2,00	50	164	1-5%	FBFJ750X18LJ											
																															PU80A	84 A	1,6	0,062	15	0,60	0,46	2,60	0,32	1,80
Fabric impression (FI)	UB		PU80A	84 A	1,6	0,062	15	0,60	0,46	2,60	0,32	1,80	50	164	1-5%	FBFJ750X16LL																								
																	1,6	0,078	20	0,80	0,57	3,30	0,40	2,30	50	164	1-5%	FBFJ750X2LB												
																													1,6	0,062	25	1,00	0,78	4,50	0,55	3,10	50	164	0,5-3%	FBFM750X16LH
																	2,0	0,078	35	1,38	0,98	5,60	0,68	3,90	50	164	0,5-3%	FBFM750X2LH												
3,0	0,118	50	1,97	1,47	8,40	1,03	5,90	50	164	0,5-3%	FBFM750X3LH																													





TOP SIDE: NUB TOP (NP)

Bottom side	Color	Additional features	Quality	Hardness Shore	Profile thickness		Recommended min. pulley \varnothing		k1% static		k1% relaxed		Standard roll		Recommended pretension	Order No.												
					mm	inch	mm	inch	N/mm	lbs/inch	N/mm	lbs/inch	m	ft														
Fabric impression (FI)	UB		PU65A	72 A	2,0	0,078	15	0,60	0,29	1,60	0,20	1,10	50	164	1-5%	FBFG750X2LB												
																	1,6	0,062	15	0,60	0,48	2,70	0,34	1,90	50	164	1-5%	FBFJ750X16LF
																	1,6	0,062	25	1,00	0,82	4,78	0,57	3,33	50	164	0,5-3%	FBFM750X16LB

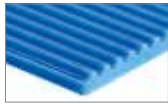
Elastic conveyor belts up to 730 mm





TOP SIDE: TRANSVERSAL GROOVES (TGA)

Bottom side	Color	Additional features	Quality	Hardness Shore	Profile thickness		Recommended min. pulley Ø		k1% static		k1% relaxed		Standard roll		Recommended pretension	Order No.
					mm	inch	mm	inch	N/mm	lbs/inch	N/mm	lbs/inch	m	ft		
 Diamond (ID)	UB	UV ↓↓↓	PU80A	84 A	2,8	0,110	25	1,00	0,57	3,30	0,40	2,30	50	164	1-5%	FBFJ750X28LP
 Fabric impression (FI)	UB		PU80A	84 A	2,5	0,098	20	0,80	0,51	2,90	0,36	2,00	50	164	1-5%	FBFJ750X25LL
			PU95A	95 A	2,5	0,098	40	1,57	0,87	5,00	0,61	3,50	50	164	0,5-3%	FBFM750X25LB
					3,5	0,137	55	2,17	1,39	7,90	0,97	5,50	50	164	0,5-3%	FBFM750X35LI



TOP SIDE: ROUGH IMPRESSION (RI)

Bottom side	Color	Additional features	Quality	Hardness Shore	Profile thickness		Recommended min. pulley Ø		k1% static		k1% relaxed		Standard roll		Recommended pretension	Order No.
					mm	inch	mm	inch	N/mm	lbs/inch	N/mm	lbs/inch	m	ft		
 Smooth matt (SM)	UB	MICRO CLEAN, Water, No oil, No salt	PU65A	72 A	3,0	0,118	18	0,71	0,36	2,00	0,25	1,40	50	164	1-5%	FBFG750X30LA
 Diamond (ID)	UB	MICRO CLEAN, Water, No oil, No salt, -30°C	PU75A	80 A	2,0	0,078	20	0,80	0,31	1,70	0,21	1,20	50	164	1-5%	FBFI750X20LC
					3,0	0,118	30	1,20	0,51	2,90	0,36	2,00	50	164	1-5%	FBFI750X30LC

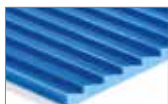

TOP SIDE: SAWTOOTH (EST)

Bottom side	Color	Additional features	Quality	Hardness Shore	Profile thickness		Recommended min. pulley Ø		k1% static		k1% relaxed		Standard roll		Recommended pretension	Order No.
					mm	inch	mm	inch	N/mm	lbs/inch	N/mm	lbs/inch	m	ft		
 Slightly rough (SR)	UB	Water, No oil, No salt, -30°C	PU75A	80 A	3,0	0,118	20	0,79	0,32	1,86	0,23	1,33	25	82	1-5%	FBFI750X30LD
					4,0	0,157	30	1,18	0,54	3,13	0,38	2,20	25	82	1-5%	FBFI750X40LB

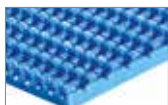

TOP SIDE: SUPERGRIP (ESG)

Bottom side	Color	Additional features	Quality	Hardness Shore	Profile thickness		Recommended min. pulley Ø		k1% static		k1% relaxed		Standard roll		Recommended pretension	Order No.
					mm	inch	mm	inch	N/mm	lbs/inch	N/mm	lbs/inch	m	ft		
 Slightly rough (SR)	UB	Water, No oil, No salt, -30°C	PU75A	80 A	4,0	0,157	35	1,38	0,58	3,36	0,41	2,38	25	82	1-5%	FBFI750X40LA



Conveyor belts for intralogistics

Elastic conveyor belts reduce the costs of system design, as tensioning device can often be avoided. Depending on the goods to be conveyed or the type of conveyor (e.g. accumulation mode, inclined conveyor), a wide variety of belt features are required. With BEHAbelt's new 2C process, two different degrees of hardness can be combined in one belt, for example to provide the transport side with more grip for inclined conveyors.



FDA
EC



TOP SIDE: SMOOTH MATT (SM)

Bottom side	Color	Quality	Hardness Shore	Profile thickness		Recommended min. pulley \varnothing		k1% static		k1% relaxed		Standard roll		Recommended pretension	Order No.
				mm	inch	mm	inch	N/mm	lbs/inch	N/mm	lbs/inch	m	ft		
 Fabric impression (FI)	SW	PU75A	80 A	1,6	0,062	15	0,60	0,34	2,00	0,24	1,40	50	164	1-5%	FBF750X16SB



FDA
EC



TOP SIDE: SLIGHTLY ROUGH (SR)

Bottom side	Color	Quality	Hardness Shore	Profile thickness		Recommended min. pulley \varnothing		k1% static		k1% relaxed		Standard roll		Recommended pretension	Order No.
				mm	inch	mm	inch	N/mm	lbs/inch	N/mm	lbs/inch	m	ft		
 Fabric impression (FI)	SW	PU80A	84 A	1,2	0,047	10	0,40	0,32	1,80	0,23	1,30	50	164	1-5%	FBFJ750X12SB
				1,6	0,062	15	0,60	0,43	2,50	0,30	1,70	50	164	1-5%	FBFJ750X16SB
		PU80A PU65A	84 A 72 A	2,0	0,078	18	0,71	0,40	2,30	0,28	1,60	50	164	1-5%	FBFJG750X2S
		PU55D PU65A	55 D 72 A	1,9	0,074	25	1,0	0,82	4,70	0,58	3,30	50	164	0,5-3%	FBFNG750X19S

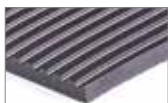

FDA
EC



TOP SIDE: LONGITUDINAL GROOVES (LGB)

Bottom side	Color	Quality	Hardness Shore	Profile thickness		Recommended min. pulley \varnothing		k1% static		k1% relaxed		Standard roll		Recommended pretension	Order No.
				mm	inch	mm	inch	N/mm	lbs/inch	N/mm	lbs/inch	m	ft		
 Fabric impression (FI)	SW	PU80A PU65A	84 A 72 A	2,2	0,086	18	0,71	0,47	2,70	0,33	1,90	50	164	1-5%	FBFGJ750X22S

Machine tapes up to 730 mm



Machine tapes

BEHAbelt complements its versatile belt portfolio with the addition of elastic machine tapes made of TPU. Machine tapes have already been established on the market for many years and are often offered in green/black or blue/black versions with antistatic properties.

In addition to reinforced belt constructions, elastic versions are also used to adapt to the application requirements.

INDUSTRIES / APPLICATIONS

- Packaging and weighing technology
- Intralogistics (mainly distribution belts)
- Enveloping and franking systems
- Printing, paper industry
- Textile industry
- Blue types are suitable for direct contact with food
- Alternative for vertical shaft drives

ADVANTAGES / FEATURES

- Consistent longitudinal flexibility (due to homogeneous belt connection without gluing, design as transverse splice possible)
- Reduced energy consumption due to high longitudinal flexibility and thus also gentle motor and shaft loads
- Excellent bending properties and thus ideally suited for small pulley diameters
- High abrasion resistance and generally good chemical resistance
- Continuous antistatic belt designs offer dissipation properties for antistatic charges on the upper and lower side of the belt.

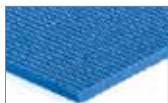





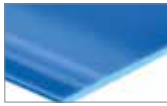

TOP SIDE: SLIGHTLY ROUGH (SR)

Bottom side	Color	Additional features	Quality	Hardness Shore	Profile thickness		Recommended min. pulley \varnothing		k1% static		k1% relaxed		Standard roll		Recommended pretension	Order No.
					mm	inch	mm	inch	N/mm	lbs/inch	N/mm	lbs/inch	m	ft		
Fabric impression (FI)	UB		PU80A	84 A	1,0	0,039	10	0,40	0,30	1,70	0,21	1,20	50	164	1-5%	FBFJ750X10L
					1,2	0,047	10	0,40	0,36	2,10	0,25	1,40	50	164	1-5%	FBFJ750X12L
					1,6	0,062	15	0,60	0,48	2,70	0,34	1,90	50	164	1-5%	FBFJ750X16L
					2,0	0,078	20	0,80	0,60	3,40	0,42	2,40	50	164	1-5%	FBFJ750X20L
Fabric impression (FI)	SW	2K	PU80A PU65A	84 A 72 A	1,8	0,070	15	0,60	0,41	2,40	0,29	1,70	50	164	1-5%	FBFJG750X18L
					0,9	0,035	8	0,31	0,24	1,40	0,17	1,00	50	164	1-5%	FBFJ750X09LA
		⚡	PU80A	84 A	1,2	0,047	10	0,40	0,33	1,90	0,23	1,30	50	164	1-5%	FBFJ750X12LA
					1,6	0,062	15	0,60	0,43	2,50	0,30	1,70	50	164	1-5%	FBFJ750X16LA
		⚡	PU55D	55 D	1,1	0,039	15	0,60	0,71	4,00	0,50	2,80	50	164	0,5-3%	FBFN750X11L
					1,5	0,059	25	1,0	1,07	6,10	0,75	4,30	50	164	0,5-3%	FBFN750X15L
		2K	PU55D PU65A	55 D 72 A	1,9	0,074	25	1,0	0,90	5,10	0,63	3,60	50	164	0,5-3%	FBFNG750X19L
					1,2	0,047	10	0,40	0,32	1,80	0,23	1,30	50	164	1-5%	FBFJ750X12SB
		⚡	PU80A	84 A	1,6	0,062	15	0,60	0,43	2,50	0,30	1,70	50	164	1-5%	FBFJ750X16SB
					⚡ 2K	PU80A PU65A	84 A 72 A	2,0	0,078	15	0,60	0,40	2,30	0,28	1,60	50
⚡	PU55D	55 D	1,1	0,039	15			0,60	0,71	4,00	0,50	2,80	50	164	0,5-3%	FBFN750X11S
			1,5	0,059	25	1,0	0,96	5,50	0,68	3,90	50	164	0,5-3%	FBFN750X15S		
⚡ 2K	PU55D PU65A	55 D 72 A	1,9	0,074	25	1,0	0,82	4,70	0,58	3,30	50	164	0,5-3%	FBFNG750X19S		



TOP SIDE: SMOOTH GLOSS (SG) // 140 mm

Bottom side	Color	Additional features	Quality	Hardness Shore	Profile thickness		Recommended min. pulley Ø		k1% static		k1% relaxed		Standard roll		Recommended pretension	Order No.
					mm	inch	mm	inch	N/mm	lbs/inch	N/mm	lbs/inch	m	ft		
 Smooth gloss (SG)	HI		PU75A	80 A	1,0	0,039	10	0,4	0,21	1,20	0,15	1,90	50	164	1-5%	FBFI150X1LG
					1,6	0,062	15	0,6	0,34	2,00	0,24	1,40	50	164	1-5%	FBFI150X16LG
					2,0	0,078	20	0,8	0,43	2,40	0,30	1,70	50	164	1-5%	FBFI150X2LG
					3,0	0,118	25	1,0	0,64	3,70	0,45	2,60	50	164	1-5%	FBFI150X3LG
					4,0	0,157	35	1,4	0,86	4,90	0,60	3,40	50	164	1-5%	FBFI150X4LG
 Smooth gloss (SG)	CB		PU80A SAFE	84 A	1,6	0,062	15	0,6	0,48	2,78	0,34	1,97	50	164	1-5%	FBFJ15016LGM
					2,0	0,078	20	0,8	0,60	3,40	0,42	2,40	50	164	1-5%	FBFJ150X2LGM
					3,0	0,118	30	1,2	0,90	5,10	0,63	3,60	50	164	1-5%	FBFJ150X3LGM
 Smooth gloss (SG)	OR		PU80A	84 A	1,6	0,062	15	0,6	0,30	1,70	0,21	1,20	30	100	1-5%	FBFJ150X160G
					2,4	0,094	25	1,0	0,72	4,10	0,50	2,90	30	100	1-5%	FBFJ150X240G
					3,2	0,125	30	1,2	0,96	5,50	0,67	3,80	30	100	1-5%	FBFJ150X320G
 Smooth gloss (SG)	GR		PU85A	88 A	1,6	0,062	20	0,8	0,50	2,90	0,40	2,30	50	164	1-5%	FBFK150X16GG
					2,0	0,078	30	1,2	0,63	3,60	0,50	2,90	50	164	1-5%	FBFK150X2GG
					3,0	0,118	35	1,4	0,94	5,30	0,75	4,30	50	164	1-5%	FBFK150X3GG
					4,0	0,157	45	1,8	1,25	7,10	1,00	5,70	50	164	1-5%	FBFK150X4GG



Elastic conveyor belts



TOP SIDE: SMOOTH GLOSS (SG)

Bottom side	Color	Quality	Hardness Shore	Profile thickness		max. Profile width		Recommended Min. pulley Ø		k1% static		k1% relaxed		Standard roll		Recommended pretension	Order No.
				mm	inch	mm	inch	mm	inch	N/mm	lbs/inch	N/mm	lbs/inch	m	ft		
Smooth gloss (SG)	OR	PU80A	84 A	1,6	0,062	12,5	0,50	15	0,6	0,30	1,70	0,21	1,20	30	100	1-5%	FBFJOG1
				1,6	0,062	19	0,75	15	0,6	0,30	1,70	0,21	1,20	30	100	1-5%	FBFJOG2
				1,6	0,062	38	1,50	15	0,6	0,30	1,70	0,21	1,20	30	100	1-5%	FBFJOG3
				1,6	0,062	44	1,75	15	0,6	0,30	1,70	0,21	1,20	30	100	1-5%	FBFJOG4
				1,6	0,062	50	2,00	15	0,6	0,30	1,70	0,21	1,20	30	100	1-5%	FBFJOG5
				1,6	0,062	76	3,00	15	0,6	0,30	1,70	0,21	1,20	30	100	1-5%	FBFJOG6
				2,4	0,094	25	1,00	20	0,8	0,72	4,10	0,50	2,90	30	100	1-5%	FBFJOG7
				2,4	0,094	32	1,25	20	0,8	0,72	4,10	0,50	2,90	30	100	1-5%	FBFJOG8
				2,4	0,094	48	1,90	20	0,8	0,72	4,10	0,50	2,90	30	100	1-5%	FBFJOG9
				2,4	0,094	50	2,00	20	0,8	0,72	4,10	0,50	2,90	30	100	1-5%	FBFJOG10
				3,2	0,125	16	0,63	25	1,0	0,96	5,50	0,67	3,80	30	100	1-5%	FBFJOG11
				3,2	0,125	25	1,00	25	1,0	0,96	5,50	0,67	3,80	30	100	1-5%	FBFJOG12

Didn't find your belt?



No Minimum Order Quantities

According To Your Specifications

In Only 4-8 Weeks

BEHAbelt offers you the exclusive and fast realisation of your desired conveyor belt!

If a standard belt does not meet the requirements of your application, BEHAbelt offers you the unique opportunity to develop a customer-specific product. According to your specifications and your design!

FAST REALISATION (4-8 WEEKS)

- Many years of experience, in-house manufacturing of tooling, individual consulting
- Development of customer-specific conveyor belts
- Specially adapted to your application
- Especially according to your design

Tell us your application!

We will be happy to evaluate the possibilities for optimising your application with regards to conveyor belt design. In particular, the 2-component production enables a multitude of combinations of structures, hardnesses, belt properties and colours.

ECONOMIC ADVANTAGES

- Exclusivity / securing the After Sales Market
- Material combination
- Optimisation of your application through the perfect belt
- Improved service life and functionality
- Appropriate welding technology



PU COATING MATERIAL

Introduction	74
PU coating material.....	75

PU coating material

Our product group of PU coating materials is based on the careful selection of high-quality raw materials, which have been successfully tested and used in the field for a long time.

We supply coating material in rolls from 140 - 730 mm with a coating thickness of 1 - 4 mm and an available hardness range from Shore 45A to 95A for your individual application.

The extensive portfolio offers you a multitude of application optimizations and processing advantages compared to conventional coating materials such as rubber or PVC. PU coatings are the optimal combination to create high-quality and robust products, especially in connections with PU base belts; a product from a single casting.

Optimization of your application

Below you will find an overview of optimization potentials that can be achieved through coatings. We would be pleased to advise you comprehensively.

- High abrasion resistance
- Improved flexural fatigue strength
- Optimum shock absorption
- Better adhesion of the coating on the base belt (coating detachment)
- Very good grip
- Optimisation of dust operation
- Variety of surface structures for optimum contact conditions and release requirements
- Excellent chemical resistance

Selectable special features

Food industry, logistics industry etc.; the requirements could not be more varied. Within our manufacturing process we can easily realize special properties for the coatings.



Antistatic design



Resistant to hydrolysis and cleaning



FDA/EC conformity for food industry



Metal and X-ray detectable











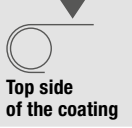













Fabrication benefits

- Uniform stable melting phase
- Very good weldability with all PU types
- Direct processing on the PU base belt without adhesive
- Homogeneous connection with the PU base belt
- Weldable coating joint



PU COATING MATERIAL // 140 mm

 Top side of the coating  Smooth gloss (SG)	Color	Features	Quality	Hardness	Profile thickness		Weight per m ² (approx.)	max. belt width		Impact on Min. pulley \varnothing		Standard roll		Order No.
				Shore	mm	inch	kg	mm	inch	mm	inch	m	ft	
	TR	PU grip	PU40A	45 A	2,0	0,078	2,4	140	5,5	+10	+0,4	50	164	FBFD140X2TG
					3,0	0,118	3,6	140	5,5	+15	+0,6	50	164	FBFD140X3TG
					4,0	0,157	4,8	140	5,5	+20	+0,8	50	164	FBFD140X4TG
	TR	 -30°C	PU60A	65 A	1,6	0,062	1,9	140	5,5	+10	+0,4	50	164	FBFF150X16TG
					2,0	0,078	2,4	140	5,5	+15	+0,6	50	164	FBFF150X2TG
					3,0	0,118	3,6	140	5,5	+20	+0,8	50	164	FBFF150X3TG
					4,0	0,157	4,8	140	5,5	+25	+1,0	50	164	FBFF150X4TG
	TR	   	PU65A	72 A	1,0	0,039	1,2	140	5,5	+10	+0,4	50	164	FBFG150X1TG
					1,6	0,062	1,9	140	5,5	+12	+0,5	50	164	FBFG150X16TG
					2,0	0,078	2,4	140	5,5	+15	+0,7	50	164	FBFG150X2TG
					3,0	0,118	3,6	140	5,5	+25	+1,0	50	164	FBFG150X3TG
					4,0	0,157	4,8	140	5,5	+35	+1,4	50	164	FBFG150X4TG
	TR	   	PU75A	80 A	1,0	0,039	1,2	140	5,5	+10	+0,5	50	164	FBFI150X1TG
					1,6	0,062	1,9	140	5,5	+15	+0,6	50	164	FBFI150X16TG
					2,0	0,078	2,4	140	5,5	+20	+0,8	50	164	FBFI150X2TG
					3,0	0,118	3,6	140	5,5	+30	+1,2	50	164	FBFI150X3TG
4,0					0,157	4,8	140	5,5	+40	+1,6	50	164	FBFI150X4TG	
TR	   	PU85A	88 A	1,0	0,039	1,2	140	5,5	+15	+0,6	50	164	FBFK150X1TG	
				1,6	0,062	1,9	140	5,5	+20	+0,8	50	164	FBFK150X16TG	
				2,0	0,078	2,4	140	5,5	+25	+1,0	50	164	FBFK150X2TG	
				3,0	0,118	3,6	140	5,5	+35	+1,4	50	164	FBFK150X3TG	
				4,0	0,157	4,8	140	5,5	+45	+1,8	50	164	FBFK150X4TG	
 PUtex / smooth (S)	RO	PU tex	PU60A	65 A	1,6	0,062	1,9	140	5,5	+10	+0,4	50	164	FBFF150X16BM
					2,0	0,078	2,4	140	5,5	+15	+0,6	50	164	FBFF150X2BM
					3,0	0,118	3,6	140	5,5	+20	+0,8	50	164	FBFF150X3BM
					4,0	0,157	4,8	140	5,5	+25	+1,0	50	164	FBFF150X4BM
 Longitudinal (LGA)	TR	   	PU65A	72 A	2,6	0,102	2,5	140	5,5	+22	+0,9	50	164	FBFG150X26TW
 Longitudinal (LGC)	WE		PU80A	84 A	3,0	0,118	2,4	140	5,5	+30	+1,2	50	164	FBFJ140X3WG

PU coating material up to 730 mm

PU COATING MATERIAL // 730 mm

 Top side of the coating	Color	Features	Quality	Hardness Shore	Profile thickness		Weight per m ² (approx.) kg	max. belt width		Impact on Min. pulley \varnothing		Standard roll		Order No.
					mm	inch		mm	inch	mm	inch	m	ft	
 Nub top (NP)	UB	   	PU65A	72 A	2,0	0,078	2,4	750	29,5	+15	+0,6	50	164	FBFG750X2LB
 Rough impression (RI)	UB	   	PU65A	72 A	3,0	0,118	3,6	750	29,5	+25	+1,0	50	164	FBFG750X30LA
 Smooth gloss (SG)	UB	   	PU75A	80 A	4,0	0,157	4,8	750	29,5	+40	+1,6	50	164	FBFI750X40LC
 Spikes (SP)	UB	  	PU80A	84 A	1,2	0,047	1,5	750	29,5	+12	+0,47	50	164	FBFJ750X12LG
 Transversal grooves (TGA)	UB	   	PU80A	84 A	2,5	0,098	2,4	750	29,5	+20	+0,8	50	164	FBFJ750X25LL
 Longitudinal grooves (LGB)	UB	   	PU80A	84 A	1,6	0,062	1,9	750	29,5	+15	+0,6	50	164	FBFJ750X16LK
 Slightly rough (SR)	UB	  	PU80A	84 A	1,2	0,047	1,4	750	29,5	+10	+0,4	50	164	FBFJ750X12L
 Diamond (ID)	UB	   	PU80A	84 A	1,6	0,062	1,9	750	29,5	+15	+0,6	50	164	FBFJ750X16LL
 Smooth matt (SM)	CB	   	PU80A SAFE	84 A	1,6	0,062	2,2	750	29,5	+15	+0,6	50	164	FBFJ750X16LE
 Supergrip (ESG)	UB	    	PU75A	80 A	4,0	0,157	3,6	750	29,5	+40	+1,57	25	82	FBFI750X40LA
 Sawtooth (EST)	UB	    	PU75A	80 A	3,0	0,118	2,4	750	29,5	+30	+1,18	25	82	FBFI750X30LD
4,0					0,157	3,6	750	29,5	+40	+1,57	25	82	FBFI750X40LB	



WELDABLE ACCESSORIES FOR CONVEYOR BELTS

V-guides / Special V-guides	79
Belt edges	84
Cleats	87
Sidewalls	88
PU sheet material	91

Weldable accessories for conveyor belts

There is a wide field of applications for synthetic conveyor belts. Depending on the industry, the products to be conveyed and the given machinery design, conveyor belts not only have to be fabricated to specific dimensions (length and width), often they are also equipped with cleats, sidewalls or tracking elements. BEHAbelt offers a wide range of flat belt accessories, homogeneously extruded from PU in different Shore hardness grades.

Our flat belt accessories consist of the same raw materials as the conveyor belts to ensure the best possible weldability and a long service life in the application.

Of course, the BEHAbelt flat belt accessories are also available with FDA/EC/USDA compliance on request and can further be offered with special features such as detectable, UV-C resistance or hydrolysis resistance.



Notched V-guides or guide profiles

- Frequently used as guiding profile on the running side to support the tracking of e.g. long and/or narrow conveyor belts, also to absorb transversal forces during lateral product feeding.
- Can be applied on the conveying side instead of corrugated sidewalls.
- Many versions available.



Belt edges

- For the stabilization and guidance of curved belts. Belt edges are usually applied by sewing or glued.
- Many versions available.
- Customer-specific special profiles possible.



Cleats / PU sheet material

- For carrying single or bulk goods on inclined conveyors.
- 3 versions available
 - flat foot
 - narrow foot
 - Sheet material (up to 8mm thick) without foot



Corrugated sidewalls

- Usually in combination with cleats on inclined or declined conveyor belts to prevent products from dropping sideways.
- 2 versions available
 - with foot
 - PUflex flat stock material without foot

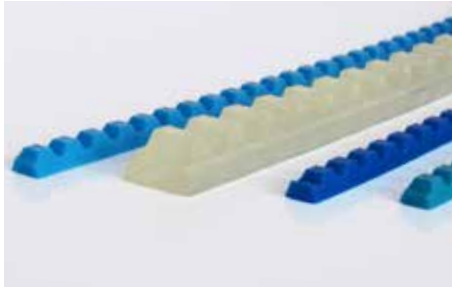

V-guides / Guiding profiles

- All profiles are made from PU and can be supplied in various colours upon request.
- Approved for use in food contact applications according to FDA/EC (PU70A).
- **Excellent adhesion with PU belts** by means of hot air or high frequency welding.

PU60A transparent smooth

BEST SUITABLE FOR BELT QUALITY **PU80A**



Order No.		Profile dimension	Standard roll		Recommended min. pulley \varnothing			
unnotched	notched	mm	m	ft	unnotched		notched	
					mm	inch	mm	inch
FBKF6YTG	FBKF6YTD	6 x 4 (Y)	150	492	25,0	1,0	20,0	0,8
FBKF8MTG	FBKF8MTGD	8 x 5 (M)	150	492	30,0	1,2	25,0	1,0
FBKF10ZTG	FBKF10ZTGD	10 x 6 (Z)	150	492	40,0	1,6	30,0	1,2
FBKF13ATG	FBKF13ATGD	13 x 8 (A)	150	492	60,0	2,4	45,0	1,8
FBKF17BTG	FBKF17BTGD	17 x 11 (B)	100	328	80,0	3,2	60,0	2,4
FBKF22CTG	FBKF22CTGD	22 x 14 (C)	50	164	110,0	4,4	85,0	3,3

approx. 65° Shore A

approx. Coefficient of friction μ : Steel: 0,85 | PE: 0,50 | HDPE: 0,45

PU60A sky blue smooth

BEST SUITABLE FOR BELT QUALITY **PU80A**

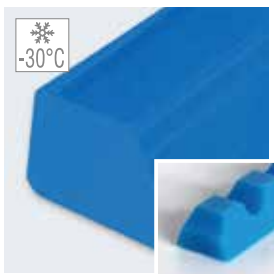

Order No.		Profile dimension	Standard roll		Recommended min. pulley \varnothing			
unnotched	notched	mm	m	ft	unnotched		notched	
					mm	inch	mm	inch
FBKF6YLG	FBKF6YLGD	6 x 4 (Y)	150	492	25,0	1,0	20,0	0,8
FBKF8MLG	FBKF8MLGD	8 x 5 (M)	150	492	30,0	1,2	25,0	1,0
FBKF10ZLG	FBKF10ZLGD	10 x 6 (Z)	150	492	40,0	1,6	30,0	1,2
FBKF13ALG	FBKF13ALGD	13 x 8 (A)	150	492	60,0	2,4	45,0	1,8
FBKF17BLG	FBKF17BLGD	17 x 11 (B)	100	328	80,0	3,2	60,0	2,4

approx. 65° Shore A

approx. Coefficient of friction μ : Steel: 0,85 | PE: 0,50 | HDPE: 0,45

PU60A ultramarine blue smooth

BEST SUITABLE FOR BELT QUALITY **PU80A**

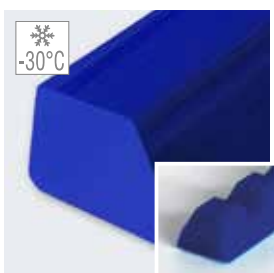

Order No.		Profile dimension	Standard roll		Recommended min. pulley \varnothing			
unnotched	notched	mm	m	ft	unnotched		notched	
					mm	inch	mm	inch
FBKF6YLGE	FBKF6YLGf	6 x 4 (Y)	150	492	25,0	1,0	20,0	0,8
FBKF8MLGE	FBKF8MLGF	8 x 5 (M)	150	492	30,0	1,2	25,0	1,0
FBKF10ZLGE	FBKF10ZLGF	10 x 6 (Z)	150	492	40,0	1,6	30,0	1,2
FBKF13ALGE	FBKF13ALGF	13 x 8 (A)	150	492	60,0	2,4	45,0	1,8
FBKF17BLGE	FBKF17BLGF	17 x 11 (B)	100	328	80,0	3,2	60,0	2,4

approx. 65° Shore A

approx. Coefficient of friction μ : Steel: 0,85 | PE: 0,50 | HDPE: 0,45

PU65A transparent smooth

BEST SUITABLE FOR BELT QUALITY **PU75A/PU95A**



Order No.		Profile dimension mm	Standard roll		Recommended min. pulley \varnothing			
unnotched	notched		m	ft	unnotched		notched	
					mm	inch	mm	inch
FBKG5X3TG	–	5 x 3	150	492	20	0,8	–	–
FBKG6YTG	FBKG6YTGA	6 x 4 (Y)	150	492	30	1,2	25	1,0
FBKG8MTG	FBKG8MTGA	8 x 5 (M)	150	492	35	1,4	28	1,1
FBKG10ZTG	FBKG10ZTGA	10 x 6 (Z)	150	492	40	1,6	30	1,2
FBKG13ATG	FBKG13ATGA	13 x 8 (A)	150	492	65	2,6	40	1,6
FBKG17BTG	FBKG17BTGA	17 x 11 (B)	100	328	85	3,4	55	2,2
FBKG22CTG	FBKG22CTGA	22 x 14 (C)	50	164	120	4,0	90	3,5

approx. 72° Shore A

approx. Coefficient of friction μ : Steel: 0,80 | PE: 0,45 | HDPE: 0,40

PU65A ultramarine blue smooth

BEST SUITABLE FOR BELT QUALITY **PU75A/PU95A**

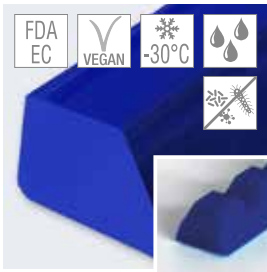

Order No.		Profile dimension mm	Standard roll		Recommended min. pulley \varnothing			
unnotched	notched		m	ft	unnotched		notched	
					mm	inch	mm	inch
FBKG5X3LG	–	5 x 3	150	492	20	0,8	–	–
FBKG6YLG	FBKG6YLGGA	6 x 4 (Y)	150	492	30	1,2	25	1,0
FBKG8MLG	FBKG8MLGA	8 x 5 (M)	150	492	35	1,4	28	1,1
FBKG10ZLG	FBKG10ZLGA	10 x 6 (Z)	150	492	40	1,6	30	1,2
FBKG13ALG	FBKG13ALGA	13 x 8 (A)	150	492	65	2,6	40	1,6
FBKG17BLG	FBKG17BLGA	17 x 11 (B)	100	328	85	3,4	55	2,2
FBKG22CLG	FBKG22CLGA	22 x 14 (C)	50	164	120	4,0	90	3,5

approx. 72° Shore A

approx. Coefficient of friction μ : Steel: 0,80 | PE: 0,45 | HDPE: 0,40

PU70A transparent smooth

BEST SUITABLE FOR BELT QUALITY **PU80A**



Order No.		Profile dimension mm	Standard roll		Recommended min. pulley \varnothing			
unnotched	notched		m	ft	unnotched		notched	
					mm	inch	mm	inch
FBKH5X3TG	–	5 x 3	150	492	25,0	1,0	–	–
FBKH6YTG	FBKH6YTGD	6 x 4 (Y)	150	492	30,0	1,2	25,0	1,0
FBKH8MTG	FBKH8MTGD	8 x 5 (M)	150	492	35,0	1,4	30,0	1,2
FBKH10ZTG	FBKH10ZTGD	10 x 6 (Z)	150	492	45,0	1,8	35,0	1,4
FBKH13ATG	FBKH13ATGD	13 x 8 (A)	150	492	70,0	2,8	55,0	2,1
FBKH17BTG	FBKH17BTGD	17 x 11 (B)	100	328	90,0	3,6	70,0	2,8
FBKH22CTG	FBKH22CTGD	22 x 14 (C)	50	164	130,0	5,2	100,0	3,9

approx. 76° Shore A

approx. Coefficient of friction μ : Steel: 0,75 | PE: 0,40 | HDPE: 0,35

PU70A sky blue smooth

BEST SUITABLE FOR BELT QUALITY **PU80A**



Order No.		Profile dimension mm	Standard roll		Recommended min. pulley \varnothing			
unnotched	notched		m	ft	unnotched		notched	
					mm	inch	mm	inch
FBKH6YLG	FBKH6YLGGA	6 x 4 (Y)	150	492	30,0	1,2	25,0	1,0
FBKH8MLG	FBKH8MLGA	8 x 5 (M)	150	492	35,0	1,4	30,0	1,2
FBKH10ZLG	FBKH10ZLGA	10 x 6 (Z)	150	492	45,0	1,8	35,0	1,4
FBKH13ALG	FBKH13ALGA	13 x 8 (A)	150	492	70,0	2,8	55,0	2,1
FBKH17BLG	FBKH17BLGA	17 x 11 (B)	100	328	90,0	3,6	70,0	2,8

approx. 76° Shore A

approx. Coefficient of friction μ : Steel: 0,75 | PE: 0,40 | HDPE: 0,35

PU70A ultramarine blue smooth

BEST SUITABLE FOR BELT QUALITY **PU80A**

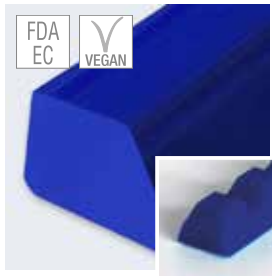

Order No.		Profile dimension	Standard roll		Recommended min. pulley \varnothing			
unnotched	notched	mm	m	ft	unnotched		notched	
					mm	inch	mm	inch
FBKH5X3LG	–	5 x 3	150	492	25,0	1,0	–	–
FBKH6YLGB	FBKH6YLG	6 x 4 (Y)	150	492	30,0	1,2	25,0	1,0
FBKH8MLGB	FBKH8MLGC	8 x 5 (M)	150	492	35,0	1,4	30,0	1,2
FBKH10ZLGB	FBKH10ZLGC	10 x 6 (Z)	150	492	45,0	1,8	35,0	1,4
FBKH13ALGB	FBKH13ALGC	13 x 8 (A)	150	492	70,0	2,8	55,0	2,1
FBKH17BLGB	FBKH17BLGC	17 x 11 (B)	100	328	90,0	3,6	70,0	2,8

approx. 76° Shore A

approx. Coefficient of friction μ : Steel: 0,75 | PE: 0,40 | HDPE: 0,35

PU70A safe capri blue smooth

BEST SUITABLE FOR BELT QUALITY **PU80A**

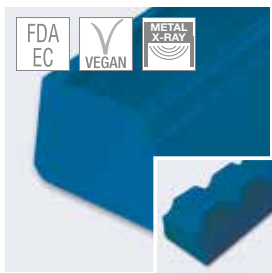

Order No.		Profile dimension	Standard roll		Recommended min. pulley \varnothing			
unnotched	notched	mm	m	ft	unnotched		notched	
					mm	inch	mm	inch
FBKF6YLGA	FBKF6YLGB	6 x 4 (Y)	150	492	30,0	1,2	25,0	1,0
FBKF8MLGA	FBKF8MLGB	8 x 5 (M)	150	492	35,0	1,4	30,0	1,2
FBKF10ZLGA	FBKF10ZLGB	10 x 6 (Z)	150	492	45,0	1,8	35,0	1,4
FBKF13ALGA	FBKF13ALGB	13 x 8 (A)	150	492	70,0	2,8	55,0	2,1
FBKF17BLGA	FBKF17BLGB	17 x 11 (B)	100	328	90,0	3,6	70,0	2,8

approx. 76° Shore A

approx. Coefficient of friction μ : Steel: 0,75 | PE: 0,40 | HDPE: 0,35

Special V-guide PU70A transparent smooth 8 x 3,2 mm



Order No.	Profile dimension	Standard roll		Recommended min. pulley \varnothing	
unnotched	mm	m	ft	mm	inch
FBKH8X32TG	8 x 3,2	150	492	25,0	1,0

BEST SUITABLE FOR BELT QUALITY **PU80A**

approx. 76° Shore A

approx. Coefficient of friction μ : Steel: 0,75 | PE: 0,40 | HDPE: 0,35

Special V-guide PU80A transparent smooth 13 x 6,5 mm / 10 x 5,0 mm

BEST SUITABLE FOR BELT QUALITY **PU80A**



Order No.	Profile dimension	Standard roll		Recommended min. pulley \varnothing	
unnotched	mm	m	ft	mm	inch
FBKJ13X65TG	13 x 6,5	200	656	60,0	2,4
FBKJ10X5TG	10 x 5,0	150	492	45,0	1,8

approx. 84° Shore A

approx. Coefficient of friction μ : Steel: 0,65 | PE: 0,35 | HDPE: 0,30

V-guides / Special guiding profiles

PU60A transparent smooth 9 x 4,5 mm

BEST SUITABLE FOR BELT QUALITY **PU75A/PU95A**



Order No.	Profile dimension	Standard roll		Recommended min. pulley \varnothing		
		mm	m	ft	mm	inch
FBSF9X45TG	9 x 4,5		150	492	30	1,18



For tracking belts in round belt beads in intralogistics

approx. 65° Shore A

approx. Coefficient of friction μ : Steel: 0,80 | PE: 0,45 | HDPE: 0,40

Half round PU70A transparent smooth

BEST SUITABLE FOR BELT QUALITY **PU80A**



Order No.	Profile dimension	Standard roll		Recommended min. pulley \varnothing		
		mm	m	ft	mm	inch
FBIH8X4TG	8 x 4		40	132	30	1,2
FBIH10X5TG	10 x 5		30	100	35	1,4
FBIH12X6TG	12 x 6		40	132	45	1,8
FBIH15X7TG	15 x 7		30	100	60	2,4
FBIH18X9TG	18 x 9		40	132	80	3,2

approx. 76° Shore A

approx. Coefficient of friction μ : Steel: 0,70 | PE: 0,40 | HDPE: 0,35



Rectangular guide profile on timing belt



Half-round guide profile on conveyor belt

Further profiles available on request

PU75A



Order No.	FBTI5X5X9HI
Dimension	5 x 5,5 x 9 mm
Hardness	approx. 80° Shore A
Color	sky blue
Reinforced	Aramid

PU60A transparent matt 19 x 8 mm

BEST SUITABLE FOR BELT QUALITY **PU80A**



Order No.	Profile dimension	Standard roll		Recommended min. pulley \emptyset		
		mm	m	ft	mm	inch
FBSF19X8TB	19 x 8		100	328	60	2,4
FBSF19X8TD*	19 x 8		100	328	60	2,4

* delivered on a wooden spool

approx. 65° Shore A

approx. Coefficient of friction μ : Steel: 0,85 | PE: 0,50 | HDPE: 0,45

PU85A ultramarine blue 22 x 8 mm

BEST SUITABLE FOR BELT QUALITY **PU80A**



Order No.	Color	Profile dimension	Standard roll		Recommended min. pulley \emptyset	
			mm	m	ft	mm
FBFK22X8LG	ultramarine blue	22 x 8	50	164	95	3,7

PU85A, approx. 88° Shore A

approx. Coefficient of friction μ : Steel: 0,60 | PE: 0,35 | HDPE: 0,30

PU80A ultramarine blue 16 x 8 mm

BEST SUITABLE FOR BELT QUALITY **PU80A**



Order No.	Profile dimension	Standard roll		Recommended min. pulley \emptyset		
		mm	m	ft	mm	inch
FBFJ16X8LG	16 x 8		50	164	80	3,15

approx. 84° Shore A

approx. Coefficient of friction μ : Steel: 0,65 | PE: 0,35 | HDPE: 0,30

PU75A ultramarine blue smooth 8 x 8 mm

BEST SUITABLE FOR BELT QUALITY **PU75A/PU95A**

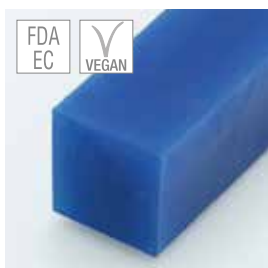

Order No.	Profile dimension	Standard roll		Recommended min. pulley \emptyset		
		mm	m	ft	mm	inch
FBFI8X8LG	8 x 8		50	164	75	2,95

approx. 80° Shore A

approx. Coefficient of friction μ : Steel: 0,70 | PE: 0,40 | HDPE: 0,35

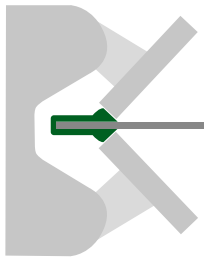

Belt edges / belt curve guiding profiles

Belt edge profiles are used to stabilise and track curved belts. The profiles are usually sewn or glued onto the curved belt. The profile bead supports the curved belt during operation.

Advantages: High tear resistance, high flexibility, low abrasion, individual colouring

Splicing belt edges

Welding the belt edges for curved belts is easy to do and eliminates the potential weak point caused by the unconnected belt edge ends.

The exchangeable adapter inserts in the guiding clamps are specially designed for the respective belt edges. This ensures that the belt edge ends are correctly aligned for the subsequent butt welding using hot paddles. **p. 104**



PU80A, 13 x 26 mm, transparent

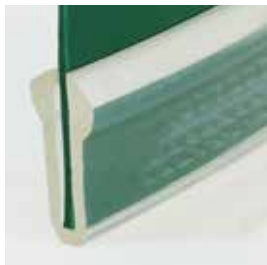

approx. 84° Shore A

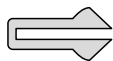

Order No.	Profile dimension mm	Cross section cm ²	approx. weight kg/100m	Standard roll		Recommended min. pulley Ø	
				m	ft	mm	inch
FBSP80A13X26	13 x 26	1,49	17,9	30,0	100,0	+100	+4,0



Adapter insert 13x26mm
for guide clamp FZ02/3
Order No. FBWFZ020T29

PU65A, 75A, 85A, 14 x 28 mm, emerald green



approx. 72°, 80°, 88° Shore A



Order No.	Profile dimension mm	Cross section cm ²	approx. weight kg/100m	Standard roll		Recommended min. pulley Ø	
				m	ft	mm	inch
FBGK65A14X28	14 x 28	1,9	22,8	30,0	100,0	+80	+3,2
FBSP75A14X28	14 x 28	1,9	22,8	30,0	100,0	+100	+4,0
FBSP85A14X28	14 x 28	1,9	22,8	30,0	100,0	+140	+5,5



Adapter insert 14x28mm
for guide clamp FZ02/3
Order No. FBWFZ020T21

PU65A, 16,5 x 33 mm, emerald green

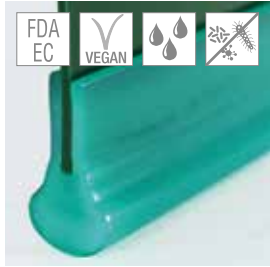

approx. 72° Shore A

Order No.	Profile dimension mm	Cross section cm ²	approx. weight kg/100 m	Standard roll		Recommended min. pulley \varnothing	
				m	ft	mm	inch
FBSP65A16X33	16,5 x 33	2,64	31,6	30	100	+100	+3,94

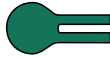

Adapter insert 16,5x33mm
for guide clamp FZ02/3
Order No. FBWFZ020T33

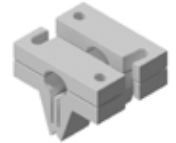

PU80A, 8,8 x 18 mm, emerald green

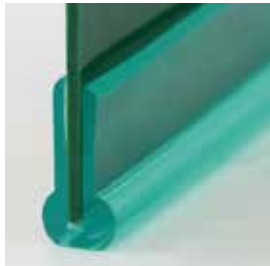

approx. 84° Shore A

Order No.	Profile dimension mm	Cross section cm ²	approx. weight kg/100 m	Standard roll		Recommended min. pulley \varnothing	
				m	ft	mm	inch
FBSP80A88X18	8,8 x 18	0,62	7,4	30,0	100,0	+65	+2,6

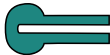

Adapter insert 8,8x18mm
for guide clamp FZ02/3
Order No. FBWFZ020T34



PU80A Belt edge 8,5 x 37 mm, emerald green

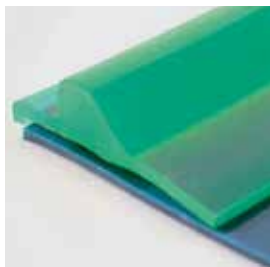

approx. 84° Shore A

Order No.	Profile dimension mm	Cross section cm ²	approx. weight kg/100 m	Standard roll		Recommended min. pulley \varnothing	
				m	ft	mm	inch
FBSP80A35X37	8,5 x 37	1,2	14,3	30,0	100,0	+60	+2,4



Adapter insert 8,5x37mm
for guide clamp FZ02/3
Order No. FBWFZ020T31



PU65A Belt edge 10 x 35 mm, transparent

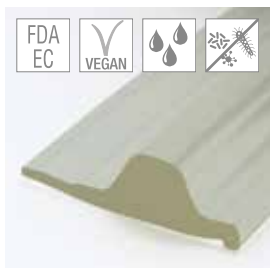

approx. 72° Shore A

Order No.	Profile dimension mm	Cross section cm ²	approx. weight kg/100 m	Standard roll		Recommended min. pulley \varnothing	
				m	ft	mm	inch
FBSP65A10X35	10 x 35	1,6	19,8	30,0	100,0	+60	+2,4



Adapter insert 10x35mm
for guide clamp FZ02/3
Order No. FBWFZ020T30



PU75A, 17 x 33 mm, emerald green



approx. 80° Shore A



Order No.	Profile dimension mm	Cross section cm ²	approx. weight kg/100m	Standard roll		Recommended min. pulley \varnothing	
				m	ft	mm	inch
FBSI17X33GG	17 x 33	2,54	30,4	30,0	100,0	+120	+4,75

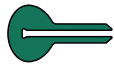

Adapter insert 17x33mm
for guide clamp FZ02/3
Order No. FBWFZ020T35

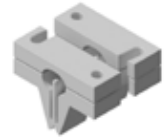

PU75A, 13 x 38 mm, transparent

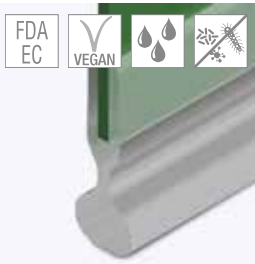

approx. 80° Shore A



Order No.	Profile dimension mm	Cross section cm ²	approx. weight kg/100m	Standard roll		Recommended min. pulley \varnothing	
				m	ft	mm	inch
FBSI13X38TG	13 x 38	2,48	29,8	30,0	100,0	+80	+3,15



Adapter insert 13x38mm
for guide clamp FZ02/3
Order No. FBWFZ020T41



PU65A, 10,5 x 22 mm, translucent green



approx. 72° Shore A



Order No.	Profile dimension mm	Cross section cm ²	approx. weight kg/100m	Standard roll		Recommended min. pulley \varnothing	
				m	ft	mm	inch
FBSG105X22TG	10,5 x 22	1,12	13,4	30,0	100,0	+70	+2,8



Adapter insert 10,5x22mm
for guide clamp FZ02/3
Order No. FBWFZ020T36



Type: feathered foot, straight and angled

weldable to PU belts

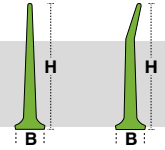
PU90A white, straight

approx. 92° Shore A

Order No.	Height (mm) H	Height (inch) H	Foot width (mm) B	Weight (g/m)	Min. pulley ∅		Standard roll	
					mm	inch	m	ft
FBCJ020WX	20,00	0,79	10,0	75,00	60	2,4	20	65
FBCJ030WX	30,00	1,18	10,0	109,00	60	2,4	20	65
FBCJ040WX	40,00	1,57	10,0	129,00	60	2,4	20	65
FBCJ050WX	50,00	2,00	10,0	235,00	60	2,4	20	65
FBCJ060WX	60,00	2,40	10,0	280,00	60	2,4	20	65

PU90A green, straight

approx. 92° Shore A

Order No.	Height (mm) H	Height (inch) H	Foot width (mm) B	Weight (g/m)	Min. pulley ∅		Standard roll	
					mm	inch	m	ft
FBCJ020GX	20,00	0,79	10,0	75,00	60	2,4	20	65
FBCJ030GX	30,00	1,18	10,0	109,00	60	2,4	20	65
FBCJ040GX	40,00	1,57	10,0	129,00	60	2,4	20	65
FBCJ050GX	50,00	2,00	10,0	235,00	60	2,4	20	65
FBCJ060GX	60,00	2,40	10,0	280,00	60	2,4	20	65

PU90A ultramarine blue, straight

approx. 92° Shore A

Order No.	Height (mm) H	Height (inch) H	Foot width (mm) B	Weight (g/m)	Min. pulley ∅		Standard roll	
					mm	inch	m	ft
FBCJ020LAX	20,00	0,79	10,0	75,00	60	2,4	20	65
FBCJ030LAX	30,00	1,18	10,0	109,00	60	2,4	20	65
FBCJ040LAX	40,00	1,57	10,0	129,00	60	2,4	20	65
FBCJ050LAX	50,00	2,00	10,0	235,00	60	2,4	20	65
FBCJ060LAX	60,00	2,40	10,0	280,00	60	2,4	20	65

PU90A sky blue, straight

approx. 92° Shore A

Order No.	Height (mm) H	Height (inch) H	Foot width (mm) B	Weight (g/m)	Min. pulley ∅		Standard roll	
					mm	inch	m	ft
FBCJ020LX	20,00	0,79	10,0	75,00	60	2,4	20	65
FBCJ030LX	30,00	1,18	10,0	109,00	60	2,4	20	65
FBCJ040LX	40,00	1,57	10,0	129,00	60	2,4	20	65
FBCJ050LX	50,00	2,00	10,0	235,00	60	2,4	20	65
FBCJ060LX	60,00	2,40	10,0	280,00	60	2,4	20	65

PU90A ultramarine blue / sky blue, angled



approx. 92° Shore A

Color	Order No.	Height (mm) H	Height (inch) H	Foot width (mm) B	Weight (g/m)	Min. pulley ∅		Standard roll	
						mm	inch	m	ft
Ultramarine blue	FBCJ040LAA	40,00	1,57	10,0	202,00	60	2,4	3	10
Ultramarine blue	FBCJ050LAA	50,00	2,00	10,0	245,00	60	2,4	3	10
Sky blue	FBCJ040LX	40,00	1,57	10,0	202,00	60	2,4	3	10
Sky blue	FBCJ050LX	50,00	2,00	10,0	245,00	60	2,4	3	10

Cleats / Flat belt material for sidewalls

Further profiles available on request

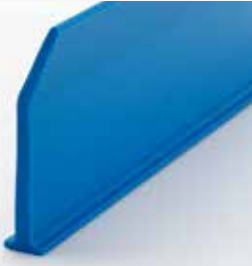
PU90A



Order No.	FBCJ030LAA FBCJ060LAA
Height	30 / 60 mm
Hardness	approx. 92° Shore A
Color	sky blue, ultramarine blue

PU80A

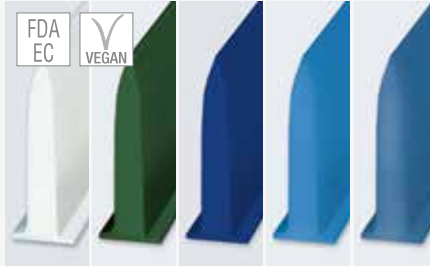

Order No.	FBCJ...
Height	25...70 mm
Hardness	approx. 84° Shore A
Color	white, green, ultramarine blue, sky blue, capri blue
Type	flat foot

PU90A



Order No.	FBCJ...LCX
Height	20...60 mm
Hardness	approx. 92° Shore A
Color	capri blue



PUflex flat belt material for sidewalls

Flat belt strips for direct welding onto the conveyor belt

- Material extremely flexible with good abrasion and cut resistance
- Very good and easy weldability
- Food approval FDA/EC compliant
- For the individual implementation of your corrugated edge refinement

PU80A Flat belt 140 mm for sidewalls



Order No.	Color*	Profile thickness*		Belt width		Standard roll	
		mm	inch	mm	inch	m	ft
FBFJ140X17LB	white	1,7	43/64	140	5,5	115	377
FBFJ140X17LG	green	1,7	43/64	140	5,5	115	377
FBFJ140X17LA	sky blue	1,7	43/64	140	5,5	115	377
FBFJ140X17WG	ultramarine blue	1,7	43/64	140	5,5	115	377
FBFJ140X2WG	white	2,0	5/64	140	5,5	125	410
FBFJ140X2GG	green	2,0	5/64	140	5,5	125	410
FBFJ140X2LG	sky blue	2,0	5/64	140	5,5	125	410
FBFJ140X2LA	ultramarine blue	2,0	5/64	140	5,5	125	410
FBFJ140X25WG	white	2,5	3/32	140	5,5	101	331
FBFJ140X25GG	green	2,5	3/32	140	5,5	101	331
FBFJ140X25LG	sky blue	2,5	3/32	140	5,5	101	331
FBFJ140X25LA	ultramarine blue	2,5	3/32	140	5,5	101	331

very good and
easy weldability

approx. 84° Shore A

approx. Coefficient of friction μ : Steel: 0,60 | PE: 0,30 | HDPE: 0,25

*further colors and belt thicknesses on request

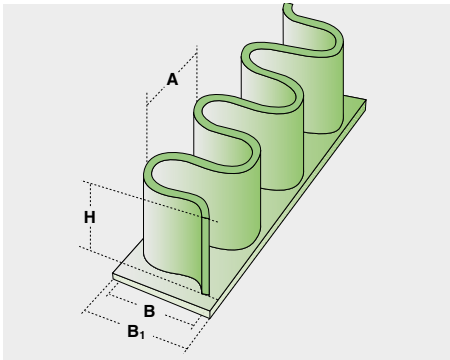

PUflex sidewalls with foot

Sidewalls with foot for welding onto the conveyor belt

- Extremely flexible material with good abrasion and cut resistance
- Very good and easy weldability
- Approved for use in food contact applications in compliance with FDA/EC
- The version with foot allows for particularly small pulley diameters on account of the high degree of undulation of the wave profile

Splicing sidewalls

Splice sidewalls precisely and easily:

The FZ02/3W guide clamp are precisely adapted to the pitch and undulation of BEHAbelt sidewalls up to a height of 50 mm. **p. 105**



PU80A white



Order No.	Height H		Wave width B	Base width B1	Pitch of waves A	Approx. weight	Standard roll	Pulley-Diameter (∅)		
	mm	inch						Minimum	Recommended	Counterflex
FBVH020W	20,00	0,79	23,00	32,00	25,40	200	100	35	70	70
FBVH030W	30,00	1,18	23,00	32,00	25,40	240	100	55	80	110
FBVH040W	40,00	1,57	23,00	32,00	25,40	280	100	75	90	150
FBVH050W	50,00	1,97	23,00	32,00	25,40	330	100	80	100	160
FBVH060W	60,00	2,36	45,00	55,00	50,80	480	100	90	110	180
FBVH080W	80,00	3,15	45,00	55,00	50,80	590	50	125	130	250
FBVH100W	100,00	3,94	45,00	55,00	50,80	700	50	155	160	310
FBVH120W	120,00	4,72	45,00	55,00	50,80	850	50	170	185	340

approx. 84° Shore A

PU80A green



Order No.	Height H		Wave width B	Base width B1	Pitch of waves A	Approx. weight	Standard roll	Pulley-Diameter (∅)		
	mm	inch						Minimum	Recommended	Counterflex
FBVH020G	20,00	0,79	23,00	32,00	25,40	200	100	35	70	70
FBVH030G	30,00	1,18	23,00	32,00	25,40	240	100	55	80	110
FBVH040G	40,00	1,57	23,00	32,00	25,40	280	100	75	90	150
FBVH050G	50,00	1,97	23,00	32,00	25,40	330	100	80	100	160
FBVH060G	60,00	2,36	45,00	55,00	50,80	480	100	90	110	180
FBVH080G	80,00	3,15	45,00	55,00	50,80	590	50	125	130	250
FBVH100G	100,00	3,94	45,00	55,00	50,80	700	50	155	160	310
FBVH120G	120,00	4,72	45,00	55,00	50,80	850	50	170	185	340

approx. 84° Shore A

PU80A sky blue

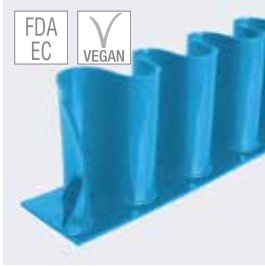

Order No.	Height H		Wave width B	Base width B1	Pitch of waves A	Approx. weight	Standard roll	Pulley-Diameter (∅)		
	mm	inch						Minimum	Recommended	Counterflex
FBVH020L	20,00	0,79	23,00	32,00	25,40	200	100	35	70	70
FBVH030L	30,00	1,18	23,00	32,00	25,40	240	100	55	80	110
FBVH040L	40,00	1,57	23,00	32,00	25,40	280	100	75	90	150
FBVH050L	50,00	1,97	23,00	32,00	25,40	330	100	80	100	160
FBVH060L	60,00	2,36	45,00	55,00	50,80	480	100	90	110	180
FBVH080L	80,00	3,15	45,00	55,00	50,80	590	50	125	130	250
FBVH100L	100,00	3,94	45,00	55,00	50,80	700	50	155	160	310
FBVH120L	120,00	4,72	45,00	55,00	50,80	850	50	170	185	340

approx. 84° Shore A

PU80A ultramarine blue

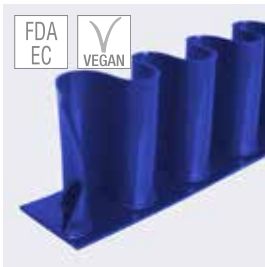

Order No.	Height H		Wave width B	Base width B1	Pitch of waves A	Approx. weight	Standard roll	Pulley-Diameter (∅)		
	mm	inch						Minimum	Recommended	Counterflex
FBVFH020LB	20,00	0,79	23,00	32,00	25,40	174	100	35	70	70
FBVFH030LB	30,00	1,18	23,00	32,00	25,40	220	100	55	80	110
FBVFH040LB	40,00	1,57	23,00	32,00	25,40	265	100	75	90	150
FBVFH050LB	50,00	1,97	23,00	32,00	25,40	310	100	80	100	160
FBVFH060LB	60,00	2,36	45,00	55,00	50,80	445	100	90	110	180
FBVFH080LB	80,00	3,15	45,00	55,00	50,80	544	50	125	130	250
FBVFH100LB	100,00	3,94	45,00	55,00	50,80	642	50	155	160	310
FBVFH120LB	120,00	4,72	45,00	55,00	50,80	741	50	170	185	340

approx. 84° Shore A

Further profiles available

PU80A safe

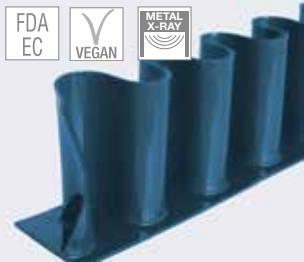

Order No.	FBVFH...LA
Height	20...120 mm
Hardness	approx. 84° Shore A
Color	capri blue

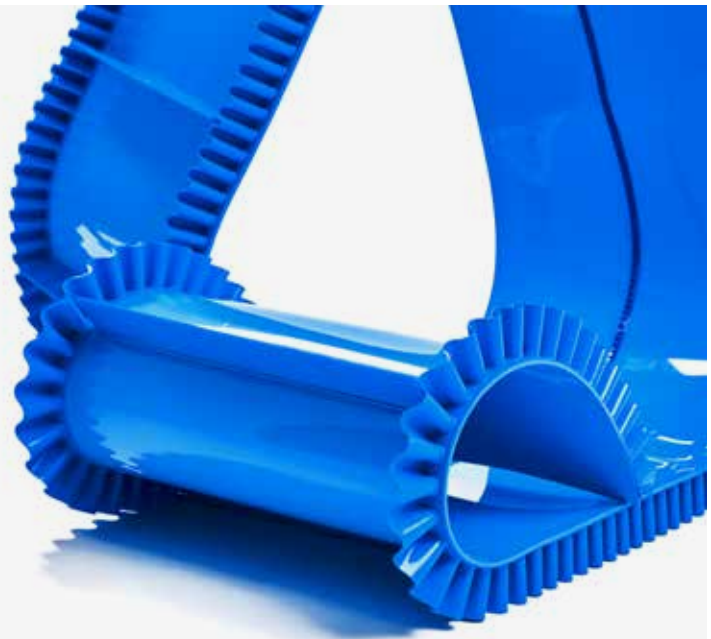

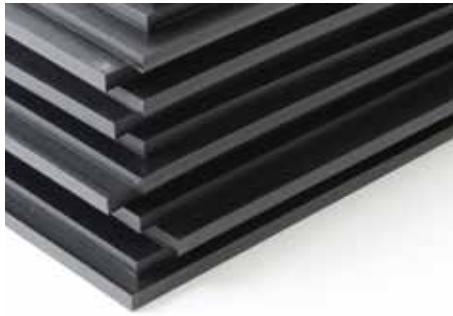

PU sheet material

BEHAbelt offers PU sheets from 4-8 mm in thickness in two categories:

- Blue FDA-compliant versions with smooth surfaces in Shore 84A and 95A
- Industrial quality with smooth/fine structured surface in Shore 84A

Typical areas of application are: Welded-on profile (cleats), scraper, skirts, impact (damping) protection or seals.

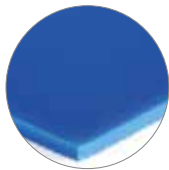



TOP SIDE: SMOOTH MATT (SM), WIDTH 750 mm

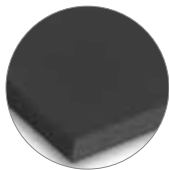

Bottom side	Color	Features	Quality	Hardness Shore	Profile thickness		Weight* per pc. approx. kg	Sheet length		Min. pulley ∅		Order No.	
					mm	inch		m	ft	horizontal	vertical		
 smooth matt (SM)	UB	FDA EC	PU80A	84 A	4,0	0,16	4,3	1,2	4,0	40	55	FBPJ12754L	
					5,0	0,20	5,4	1,2	4,0	50	70	FBPJ12755L	
					6,0	0,24	6,5	1,2	4,0	60	80	FBPJ12756L	
					8,0	0,31	8,6	1,2	4,0	80	100	FBPJ12758L	
	UB	FDA EC	MICRO CLEAN	PU95A	95 A	4,0	0,16	4,3	1,2	4,0	70	80	FBPM12754L
						5,0	0,20	5,4	1,2	4,0	90	105	FBPM12755L
						6,0	0,24	6,5	1,2	4,0	105	120	FBPM12756L
						8,0	0,31	8,6	1,2	4,0	140	150	FBPM12758L



TOP SIDE: SMOOTH MATT (SM), WIDTH 750 mm

Bottom side	Color	Features	Quality	Hardness Shore	Profile thickness		Weight* per pc. approx. kg	Sheet length		Min. pulley ∅		Order No.
					mm	inch		m	ft	horizontal	vertical	
 fabric impression (FI)	SW		PU80A	84 A	4,0	0,16	4,3	1,2	4,0	40	55	FBPJ12754S
					5,0	0,20	5,4	1,2	4,0	50	70	FBPJ12755S
					6,0	0,24	6,5	1,2	4,0	60	80	FBPJ12756S
					8,0	0,31	8,6	1,2	4,0	80	100	FBPJ12758S
 smooth matt (SM)	WE	FDA EC	PU80A	84 A	5,0	0,20	5,4	1,2	4,0	50	70	FBPJ12755W
					8,0	0,31	8,6	1,2	4,0	80	100	FBPJ12758W

Application examples



Buffer protection in the pellet depot



Cleats on conveyor belt



Work skirt e.g. in wood industry

* Sheet width 750 mm; other panel lengths are also available on request.

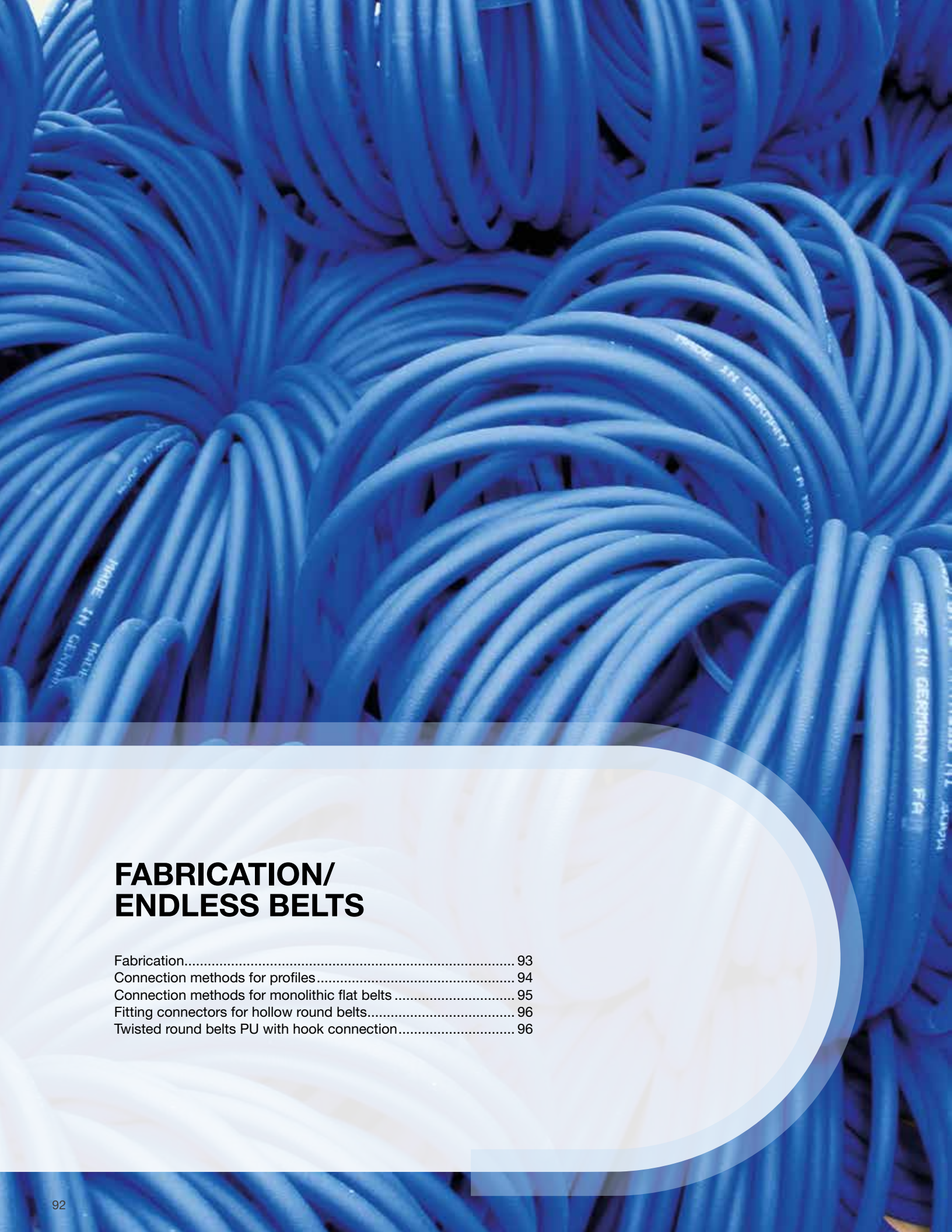

FABRICATION/ ENDLESS BELTS

Fabrication.....	93
Connection methods for profiles.....	94
Connection methods for monolithic flat belts	95
Fitting connectors for hollow round belts.....	96
Twisted round belts PU with hook connection.....	96

Fabrication

Our customers not only require belts by roll but also endless joined belts. This is why BEHAbelt offers “Express fabrication service”.
 Note: information on how to calculate a belt length for tailoring please refer to page 126.



Versatile

V- and Round and custom belt profiles in a variety of lengths and diameters and different shore hardnesses.

Welding of all belt geometries and coated belts!

Flexible

When we designed the machines of our tailoring shop our goal was to being able to fabricate both, small and big quantities, at attractive cost and to ensure delivery of orders within a couple of days only - therefore we optimized machine set-up times and lead times.

Automated

An automated welding process ensures consistent quality.



Services of Fabrication

We manufacture belt profiles and belts. The following list provides you with an overview of the currently available fabrications that BEHAbelt carries out itself. All other fabrications are covered by our partners.

Belt profiles

- Butt welding
- Butt welding with coating
- Butt welding with reinforcement
- Overlap welding with reinforcement
- Coating of belt profiles
- Twisted round belts
- Hollow round belts with quick connector
- Belt punching
- Belt notching
- Belt print and labeling

Flat belts

- Cut to width
- Butt welding (90° and 70°)
- Weld-on of belt profiles
- Machining of flat belts
- Belt print and labeling



Connection methods: Profiles

Regardless of whether you are using unreinforced belts or reinforced belts, we distinguish the following connection methods: butt and overlap welding.

Two connection methods can be used on profiles with reinforcement. Butt welding to reduce elongation without changing the belt strength. Overlap welding to reduce elongation and increase the belt strength.

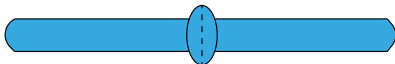

Butt welding without reinforcement

(Standard)

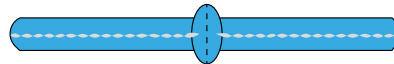

Butt welding with reinforcement

Butt welding to reduce elongation without changing the belt tensile force.

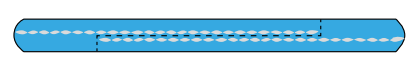

Overlap welding with reinforcement

Overlap welding to reduce elongation and increase the belt tensile force.







Joining methods: monolithic belts

Elastic monolithic PU conveyor belts from BEHAbelt offer new possibilities for endless joining due to the full PU belt construction. Due to the belt design without traction-layer, a connection by finger welding is no longer necessary, as the monolithic belt is a homogeneous belt design in itself - even in the joining area. A preferably homogeneous design of the joint is a quality criterion

both functionally and with regard to the elastic elongation behaviour of the monolithic strip. In principle, this potentially “inhomogeneous” area should be as narrow as possible, since the relatively large pretensioning force applied to monolithic belts of 0.5...5% inhomogeneity in the tape is very quickly visible in the tensioned state.

Comparison of joining methods

					
		Butt welding	Overlap welding	Finger-joint	Electrode welding
PREPARATION	+	Single 90° cut or optional 70° for demanding pulley design.	Single 90° cut.		Single 90° cut.
	-		Preparation of the lap joint. To maintain the surface structure of the conveyor belt, it is necessary to insert embossing mats.	Preparation finger. To maintain the surface structure of the conveyor belt, it is necessary to insert embossing mats.	Belt edge should be chamfered slightly.
FINISHING	+		Rework normally not necessary.	Rework normally not necessary.	
	-	Welding seam must be removed with a knife.			Very time consuming to remove welding seam.
EQUIPMENT	+	Relatively easy and mobile welding by means of a heating paddle and joining table.			Very easy, only hot air gun and electrode.
	-		Can be performed with standard hot press. However, it is best to use a special tool with a narrow heating area.	Finger punching and heating press necessary.	

CHARACTERISTICS IN THE WELDING AREA

Homogeneity	++	++	+	-
Elasticity of belt	++	++	-	+
Maintain the belt structure	++	+	+	+
CONCLUSION	recommended BEHAbelt standard	alternatively recommended belt welding	traditional belt welding	manual welding. Especially in container and funnel construction.



Butt welding with paddle welding tool



Overlap welding with hot press

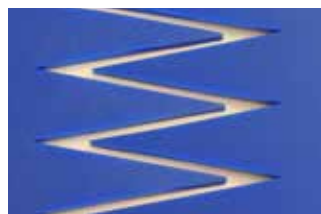

Finger joint with a hot press



Welding with electrodes

Mechanical connections

Fitting connectors for hollow round belts

Fitting connectors for quick repairs

Hollow round belts should be welded just like solid belts.

In the case of a breakdown, fitting connectors can be used for a quick repair, until the belt can be welded once again. Another advantage is the flexibility of the belt for small pulley diameters. The hollow round belts can be connected via metal connectors, as shown in the picture.

For the insertion of the metal nipples it is recommended to use a pliers.

ATTENTION: Be sure to wear gloves to press fit the metal fitting connector. **Risk of injury!**

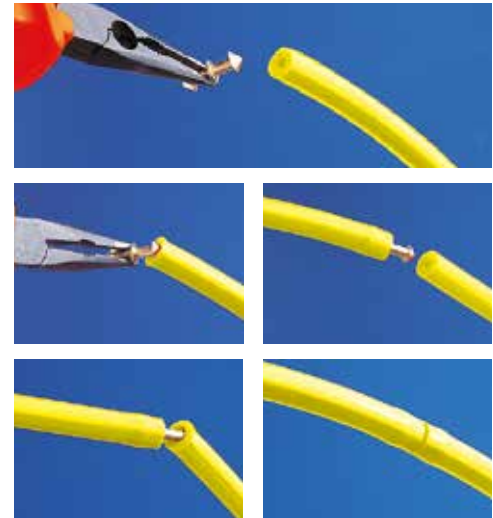

Description
Pliers SZ01

Order No.
FBWSZ01

Nipple for hollow round belts
(Outer diameter)
4,8 mm / 3/16"
6,3 mm / 1/4"
8,0 mm / 5/16"
9,5 mm / 3/8"
12,5 mm / 1/2"
15,0 mm / 19/32"

FBN048
FBN063
FBN080N
FBN095
FBN125-150
FBN125-150



SZ01 pliers for pressing nipple connectors into hollow round belts.



Brass nipples

Twisted round belts

Twisted PU round belts, also called "quick connect belts", are the perfect solution for roller conveyor systems where more than one belt is sitting on a shaft (called vertical drive).

Twisted belts are mounted with the hook open, which then is being closed with pliers once the belt is sitting in the right place.

Other material combinations on request.

Advantage

No costly and time consuming dismantling of shafts needed when installing or replacing a belt (short breakdown times).

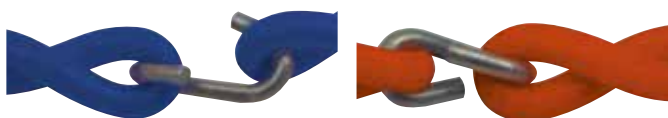

Construction: 2 x \varnothing 3 mm (\varnothing 5 mm)

You can find all product information on page 31



WELDING TOOLS

PROFILES

Friction welding machines.....	98
Paddle welding tools.....	101
Guiding clamps.....	104
Overlap welding with hot press.....	107
Overlap welding set with Z-paddle.....	111

FLAT BELTS

Heating paddle with joining table.....	113
--	-----

MISCELLANEOUS

Spare Parts & Accessories.....	115
Mandrel welding tools.....	119



Friction welding machines



original
DESIGN

Scope of delivery:

- 1 pc. Friction welding machine RS02
- 1 set standard profile jaws at your choice
- 1 pc. Torque wrench
- 1 pc. Scissors AS02
- 1 pc. Edge cutter SE02
- 1 pc. Carrying case with durable and protective foam inlay

Dimensions (HxWxD): 390 x 105 x 123 mm
Weight: approx. 2450 g, Power: 500 W

Description
RS02, 115V

Order No.
FBWRS022115V

RS02

Unique RS02 friction welding machine for polyurethane profiles prevents downtime by ensuring perfect welding in every application!

Features at a glance

- No long heating-up and set-up times, spliced within seconds.
- Precise pressure and automatical O-positioning prevents uneven welds and premature failure.
- Automatic alignment ensures that the belt ends are aligned perfectly.
- Temperature variation is never a concern (no guess-work).
- Without the risk of injury or fire due to hot metal.
- Due to its small size the RS02 press can be used in confined spaces.
- Thanks to its exchangeable jaws the RS02 is suitable for splicing round belts from \varnothing 6 mm and V-belts from 6x4mm made of polyurethane.



Tutorial video on YouTube



original
DESIGN

Scope of delivery:

- 1 pc. Friction welding machine RS02 AKKU
- 1 set standard profile jaws at your choice
- 1 pc. Torque wrench
- 1 pc. Scissors AS04
- 1 pc. Edge cutter SE02
- 2 pcs. Battery pack
- 1 pc. Charger
- 1 pc. Assortment box
- 1 pc. Carrying case with durable and protective foam inlay

Dimensions (HxWxD): 420 x 105 x 123 mm
Weight: approx. 2960 g, Power: 18 V 5Ah

Description
RS02 AKKU, 115V

Order No.
FBWRS02A115

RS02 AKKU

Battery-operated friction welding machine for polyurethane profiles for improved high-mobility maintenance.

Features at a glance

- Same characteristics as RS02, but with the following distinguishing features:
- Cordless; battery-operated
 - Larger scope of delivery

Charger



Battery Pack



Our Alu clamping jaw range

1 set of jaws consists of 4 parts

Features at a glance

- Please note each belt profile requires a matching set of jaws.
- Therefore, please select the appropriate clamping jaws for the required profile geometry.
- **On request, we also manufacture clamping jaws for PU special profiles.**

Round belts

RS Clamping jaws round belt Ø 6,0 mm	FBWSBR060
RS Clamping jaws round belt Ø 6,3 mm	FBWSBR063
RS Clamping jaws round belt Ø 7,0 mm	FBWSBR070
RS Clamping jaws round belt Ø 7,9 mm	FBWSBR079
RS Clamping jaws round belt Ø 8,0 mm	FBWSBR080
RS Clamping jaws round belt Ø 9,0 mm	FBWSBR090
RS Clamping jaws round belt Ø 9,5 mm	FBWSBR095
RS Clamping jaws round belt Ø 10,0 mm	FBWSBR100
RS Clamping jaws round belt Ø 12,0 mm	FBWSBR120
RS Clamping jaws round belt Ø 12,5 mm	FBWSBR125
RS Clamping jaws round belt Ø 12,7 mm	FBWSBR127
RS Clamping jaws round belt Ø 13,0 mm	FBWSBR130
RS Clamping jaws round belt Ø 14,0 mm	FBWSBR140
RS Clamping jaws round belt Ø 14,3 mm	FBWSBR143
RS Clamping jaws round belt Ø 15,0 mm	FBWSBR150
RS Clamping jaws round belt Ø 15,9 mm	FBWSBR159
RS Clamping jaws round belt Ø 17,0 mm	FBWSBR170
RS Clamping jaws round belt Ø 18,0 mm	FBWSBR180
RS Clamping jaws round belt Ø 19,0 mm	FBWSBR190
RS Clamping jaws round belt Ø 20,0 mm	FBWSBR200



for round belts



for V-belts

V-belts

RS Clamping jaws V-belt (Y) 6 x 4 mm	FBWSBK06
RS Clamping jaws V-belt (M) 8 x 5 mm	FBWSBK08
RS Clamping jaws V-belt (Z) 10 x 6 mm	FBWSBK10
RS Clamping jaws V-belt (A) 13 x 8 mm	FBWSBK13
RS Clamping jaws V-belt (B) 17 x 11 mm	FBWSBK17
RS Clamping jaws V-belt (C) 22 x 14 mm	FBWSBK22

V-belts special versions

RS Clamping jaws V-belt 8 x 6,5 mm	FBWSBK8X65
RS Clamping jaws V-belt 10 x 8 mm	FBWSBK10X8
RS Clamping jaws SuperGrip (Z) 10 x 6 mm	FBWSBK10G
RS Clamping jaws SuperGrip (A) 13 x 8 mm	FBWSBK13G
RS Clamping jaws SuperGrip (B) 17 x 11 mm	FBWSBK17G
RS Clamping jaws SuperGrip (C) 22 x 14 mm	FBWSBK22G
RS Clamping jaws (B) 17 x 11 for brush 90°	FBWSBK17B
RS Clamping jaws (C) 22 x 14 for brush 90°	FBWSBK22B

Ridge top V-belts

RS Clamping jaws SK1 (B) 17 x 19 mm	FBWSBK17X19
RS Clamping jaws SK1 (C) 22 x 24 mm	FBWSBK22X24
RS Clamping jaws SK2 (B) 17 x 21 mm	FBWSBK17X21
RS Clamping jaws SK2 (C) 22 x 25 mm	FBWSBK22X25

Twin V-belts

RS Clamping jaws Twin V-belt 21 x 8 mm	FBWSBK21X8
RS Clamping jaws Twin V-belt (Z) 24 x 6,8 mm	FBWSBK24X68
RS Clamping jaws Twin V-belt 30 x 8 mm	FBWSBK30X8

T-Profiles

RS Clamping jaws T-Profile 15 x 5 mm	FBWSBST15X5
RS Clamping jaws T-Profile 5 x 5 x 25 mm	FBWSBST5525

Special profiles

RS Clamping jaws Square profile 11,8 x 11,8 mm	FBWSBSQ118
RS Clamping jaws U-Profile 18 x 11,8 mm	FBWSBSU180
RS Clamping jaws Prism V-belt 33 x 8 mm	FBWSBS33X8
RS Clamping jaws Peach profile 28 x 29 mm	FBWSBS28X29

FRICTION WELDING TECHNOLOGY FOR PU

The unique friction welding machine RS02 is the professional tool for the maintenance operator and also the fastest and most reliable way of welding belt profiles. Constantly good quality connections are produced in a few seconds with repeatable accuracy due to fixed welding parameters.

Welding clamping jaws tuned to the respective profile ensure reliable clamping and perfect alignment of the profile.

Thanks to its handy type of construction, the friction welding machine can even be used in narrow space conditions for comfortable welding. The recently developed battery version is now available to ensure unlimited freedom of motion.



USE

Which profiles can be welded?

The RS02 friction welding machine can be used for butt welding of PU round belts with/without reinforcement from 6 to 20 mm and PU V-belts with/without reinforcement from 6 x 4 mm to 22 x 14 mm. Still many other geometrical shapes and special profiles can be joined by means of special clamping jaws using this welding technology.



How does friction welding work?

Basically this welding technology uses the reciprocal coefficients of friction of the profile materials and thus effect fusion of the material in the joint under pressure and in executing a rotational movement. It is up to the user to decide when the process can be terminated when a welding bead has been produced all over the joint.

What has to be observed to produce a proper weld?

Clamping jaws tuned to the respective geometry are required for reliable clamping of the profiles during this procedure.

Flat and angularly cut belt ends are an important prerequisite for this welding procedure to create optimum welding conditions and produce friction over the entire joint surface. For belt profiles with reinforcement it is required before welding, as usual, to drill out the reinforcement at the joint surfaces by some millimetres to prevent the reinforcement from crossing in the joint and consequently deterioration of the welded connection.

An exception is the patented weldable glass fibre reinforcement of BEHAbelt where this working step is unnecessary.



Tutorial video on YouTube

HIGHLIGHTS

- **Mobile use** thanks to small design.
- Welding parameters defined by the speed and pressure.
- **TOP welding quality** thanks to welding results with repeatable accuracy.
- **Machine is immediately ready for use; no heating time required.**
- **High process mastery** with excellent repeat accuracy.
- **Reduction of the risk of accidents**, as no hot parts are involved.

EERGO 60 & 90

The BEHAbelt EErgo paddle welding tools were specially developed for the connection of PU and TPE profiles or flat belt strips.

Features at a glance

- Strong, fiberglass-reinforced ergonomic housing.
- Unique control panel for one-handed operation.
- No adhesion of PU and TPE materials, thanks to Teflon-coated welding paddle.
- Easy cleaning with cloth.

Highlights



Heating-up time: approx. 5 minutes.



Innovative safety rest for safe placement on the work surface.



Ergonomic design for a natural working position.



Easy to use temperature selector regulates correct temperature to weld PU or TPE profiles.



Constant welding temperature at different ambient temperatures.



Paddle lengths

EErgo 60



EErgo 90

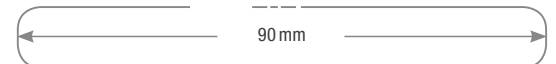

Scope of delivery:

- 1 pc. EErgo 60 or 90
- 1 pc. Carrying bag

EErgo 60

Dimensions: 185 x 210 x 55 mm (HxWxD)
Weight: approx. 380 g, Power: 120W

EErgo 90

Dimensions: 185 x 240 x 55 mm (HxWxD)
Weight: approx. 420 g, Power: 120W

Description

EErgo 60, 115V/60 mm
EErgo 90, 115V/90 mm

Order No.

FBWEE005
FBWEE020

Spare parts

Spare paddle EERGO 60

Order No. **FBWEE002**

Dimensions (HxWxD): 43 x 65 x 6 mm



Spare paddle EERGO 90

Order No. **FBWEE025**

Dimensions (HxWxD): 43 x 95 x 6 mm



Tutorial video on YouTube



PRACTICAL EERGO SETS

EErgo-Set „small“ 60

Welding set for small profiles: round belts up to 12 mm and V-belts up to profile 10 (Z)

- 1 pc. EErgo 60, Paddle welding tool
- 2 pcs. FZ01, Guide clamp
- 1 pc. AS02, Scissors small with prism
- 1 pc. SE02, Edge cutter
- 1 pc. Carrying case

EErgo-Set Vario „small“ 60

Welding set for small profiles: round belts up to 12 mm and V-belts up to profile 10 (Z)

- 1 pc. EErgo 60, Paddle welding tool
- 1 pc. FZ01 Vario, Guide clamp
- 1 pc. AS02, Scissors small with prism
- 1 pc. SE02, Edge cutter
- 1 pc. Carrying case

EErgo-Set „universal“ 60

Professional welding set for small and big profiles: Round belts in all sizes and V-belts up to profile 32x20 (D)

- 1 pc. EErgo 60, Paddle welding tool
- 2 pcs. FZ01, Guide clamp
- 1 pc. FZ02/3, Guide clamp
- 1 pc. AS04, Scissors big with angular stop
- 1 pc. SE02, Edge cutter
- 1 pc. Carrying case

EErgo-Set Vario „universal“ 60

Professional welding set for small and big profiles: Round belts in all sizes and V-belts up to profile 32x20 (D)

- 1 pc. EErgo 60, Paddle welding tool
- 1 pc. FZ01 Vario, Guide clamp
- 1 pc. FZ02/3, Guide clamp
- 1 pc. AS04, Scissors big with angular stop
- 1 pc. SE02, Edge cutter
- 1 pc. Carrying case

EErgo-Set „big“ 60

Welding set for large profiles: round belts from 8 mm and V-belts from 8x5 (M) to 32x20 (D)

- 1 pc. EErgo 60, Paddle welding tool
- 1 pc. FZ02/3, Guide clamp
- 1 pc. AS04, Scissors big with angular stop
- 1 pc. SE02, Edge cutter
- 1 pc. Carrying case

Description

EErgo-Set „small“ 115V / 60 mm
 EErgo-Set Vario „small“ 115V / 60 mm
 EErgo-Set „universal“ 115V / 60 mm
 EErgo-Set Vario „universal“ 115V / 60 mm
 EErgo-Set „big“ 115V / 60 mm

Order No.

FBWEE006
FBWEE013
FBWEE007
FBWEE015
FBWEE044



Description	EErgo 60	FZ01	FZ01 Vario	FZ02/3	AS02	AS04	SE02	Carrying Case
EErgo-Set „small“	1	2			1		1	1
EErgo-Set Vario „small“	1		1		1		1	1
EErgo-Set „universal“	1	2		1		1	1	1
EErgo-Set Vario „universal“	1		1	1		1	1	1
EErgo-Set „big“	1			1		1	1	1

SG02

The cost-effective welding technology for PU.

Features at a glance

- Easy and safe operation.
- Fixed, unregulated temperature setting.
- Reaches the welding temperature after approx. 10 min.
- Small, convenient and tough welding tool.
- No adhesion of PU material, thanks to Teflon-coated welding paddle.
- Easy to clean with a cotton cloth.

Caution! Not suitable for continuous use.



Scope of delivery:

1 pc. SG02 hot paddle welding tool
for Polyurethane (PU) 280 - 290 °C

Dimensions: 280 x 33 x 33 mm (HxWxD)

Weight: approx. 227 g

Heating time: approx. 10 minutes

Power: 80W

Description

SG02 PU - 115 V

Order No.

FBWSG02V120

Spare parts

Spare paddle SG02

Order No. **FBWTC72**

Dimensions (HxWxD): 35 x 35 x 2 mm



Spare paddle SG02 for flat profiles

Order No. **FBWTC76**

Dimensions (HxWxD): 22,5 x 75 x 2 mm



Guiding clamps



For 90° welding

Dimensions (HxWxD): 205 x 90 x 100 mm
Weight: approx. 617 g

Description

Guiding clamp FZ02/3
incl. Standard adapter insert
Adapter insert for special profiles

Order No.

FBWFZ02/3
FBWFZ020T00



Tutorial video on YouTube

Twin V-belt

Adapter set FZ02/3 for Twin V-belt 12x4,8 mm	FBWFZ020T01
Adapter set FZ02/3 for CornBelt-Profile 8x33 mm	FBWFZ020T18
Adapter set FZ02/3 for Twin 3L 24x6,8 mm	FBWFZ020T02
Adapter set FZ02/3 for Twin-A 30x8 mm	FBWFZ020T03

Belt edges

Adapter set FZ02/3 for belt edge 10x35 mm	FBWFZ020T30
Adapter set FZ02/3 for belt edge 10x35 mm	FBWFZ020T29
Adapter set FZ02/3 for belt edge 14x28 mm	FBWFZ020T21
Adapter set FZ02/3 for belt edge 3,5x37 mm	FBWFZ020T31
Adapter set FZ02/3 for belt edge 16,5x33 mm	FBWFZ020T33
Adapter set FZ02/3 for belt edge 8,8x18 mm	FBWFZ020T34
Adapter set FZ02/3 for belt edge 17x33 mm	FBWFZ020T35
Adapter set FZ02/3 for belt edge 10,5x22 mm	FBWFZ020T36

T-Profiles

Adapterset FZ02/3 for T-Profile 15x5 mm	FBWFZ020T14
Adapterset FZ02/3 for T-Profile 20x20 mm	FBWFZ020T20
Adapterset FZ02/3 for T-Profile 20x8 mm	FBWFZ020T05
Adapterset FZ02/3 for T-Profile 25x5 mm	FBWFZ020T06
Adapterset FZ02/3 for T-Profile 9x4 mm	FBWFZ020T07

FZ02/3

Guiding clamp FZ02/3 Standard

Robust and precise for V-belts from 8x5 (M) to 32x20 (D) and round belts from \varnothing 8 mm.

Adapter inserts for special profiles

Available geometries in mm: 12.5x5, 15x5, 16x8, 18x6, 24x6.8, 25x5, 30x8, 38x2, 6x4x9, 21x8, 28x10, flat profiles, square profiles, U-profiles, T-profiles 10x6, 28x10.

Other geometries available on request.



Recommended for use with E Ergo 60



FZ02/3 with Adapter set for belt edges

Further adapters available on request



FZ02/3F

Robust and precise FZ02/3F guide clamp for flat strips and special profiles

Max. width 80 mm and height 1.6–5 mm.
Adapter inserts for special profiles wider than 40 mm and flat strips with a v-guide.



Tutorial video on YouTube



For 90° welding

Dimensions: 205 x 90 x 100 mm (HxWxD)
Weight: approx. 617 g

Description
Guiding clamp FZ02/3F

Order No.
FBWFZ02/3F

FZ02/3W

Guiding clamp FZ02/3W for BEHAbelt Sidewalls

Precisely adjusted to the division and undulation up to a height of 50 mm.



Description
Guiding clamp FZ02/3W

Order No.
FBWFZ020T22

FZ01

Handy and lightweight guiding clamp for round belts up to \varnothing 12 mm and V-belts up to profile 10 (Z).

Highlights

- Fast, reliable and exceptionally precise connecting of PU and TPE profiles.
- Your choice for standard profiles!



Dimensions: 127 x 70 x 35 mm
Weight: approx. 140 g

Description
Guiding clamp FZ01

Order No.
FBWFZ01

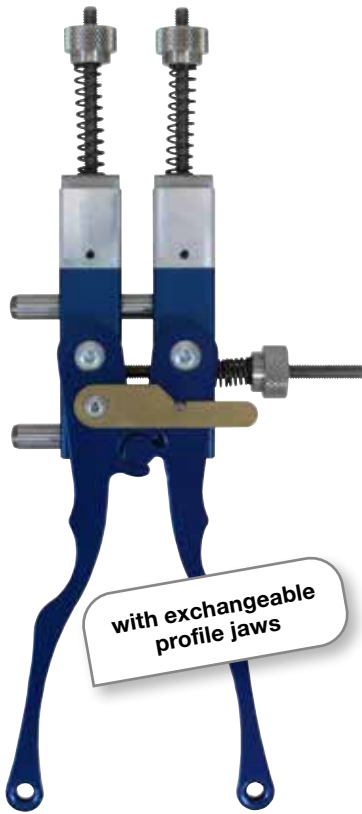

FZ01 Vario

Guiding clamp FZ01 Vario metal can be assembled in two operating modes. With and without handle

Convenient and tough for round belts up to \varnothing 10 mm and V-belts up to profile 10 (Z).

Exchangeable profile jaws allow custom profiles to be spliced easily.

Highlights

- Fast, reliable and exceptionally precise connecting of PU and TPE profiles.
- ➔ Special inserts for: PJ2, PJ3 and PJ4 ribbed V-belts.
- ➔ Your choice for standard and customized profiles!



Tutorial video on YouTube

Dimensions: 240 x 125 x 50 mm
140 x 195 x 50 mm without handle
Weight: approx. 365 g
approx. 320 g without handle

Description

FZ01 Vario
Profile jaws PJ2/PJ3/PJ4
Profile jaws T-Profile 10x4,5
Profile jaws T-Profile 9,5x3,5

Order No.

FBWFZ01V
FBWPBPJ2-4
FBWPBT10x45
FBWPBT95x35



Profile jaws for special profiles



FZ01 Vario with profile jaws for belt edges

Convertible!
Can be used in just a few steps, even without handles.



Quick clamp device for inserting the profiles in exchangeable profile jaws.



Automatic unlocking starts off lateral pressure.



Precise welding thanks to constant pressure.



Remove welding bead with side cutter.

HP01 AIR

HP01 AIR is the air-cooled version of the hot press and offers mobility thanks to its compact design.

Features at a glance

- Very easy to use.
- Reduces operator errors through a fully automatic and controlled welding and vulcanization process.
- Thanks to its exchangeable molds (**sold separately**) the HP01 is suitable for splicing many different profiles and flat belts made of PU and TPE as well as timing belts.
- User friendly operation through self-explanatory menu of controller (no expertise required).
- Perfect welding within minutes.
- Temperature variation is never a concern (no guesswork).
- Real time data logging & diagnostics function for quality assurance of the splice.
- Different types of welds possible (overlap welds, butt welds and angle welds).
- Due to its small size and the hook for hanging up the press during the welding process, the HP01 can be used in confined spaces "on-site".
- Best welding solution for reinforced profiles (aramid, polyester and steel) through overlap welding.



Heating plate dimensions: 120 x 60 mm

Scope of delivery:

1 pc. Hot press HP01 AIR, 1 pc. PPuls Controller Element, 1 pc. Edge cutter SE02, 1 pc. Screw driver, 1 pc. Scissors AS04, 1 pc. Aluminium case

Dimensions (HxWxD): 240 x 167 x 200 mm

Weight: approx. 4800 g

Description

Standard Set HP01 / Air cooling, 115 V

Order No.

FBWHP011L115



Tutorial video on YouTube

HP01 WATER

HP01 WATER is the water cooled version of the hot press and offers higher cooling capacity.

Features at a glance

Same characteristics as HP01 AIR, but with the following distinguishing features:

- Higher cooling capacity
- Cooling drum included in scope of supply
- Could also be cooled with compressed air



Scope of delivery:

1 pc. hot press HP01 WATER, 1 pc. Cooling unit 6,4 l with pump, 1 pc. PPuls Controller Element, 1 pc. Edge cutter SE02, 1 pc. Screw driver, 1 pc. Scissors AS04, 1 Set Connecting hoses, 1 pc. Aluminium case

Description

Standard Set HP01/water cooling, 115 V

Order No.

FBWHP011W115



Shaft for HP01 to use with torque wrench available as accessory

FBWHPSD12

Molds for HP01

Molds for HP01 hot presses

For round and V-belts made of PU and TPE as well as other geometries. Other sizes available on request.



Mold for Twin V-belt

Round belts

Mold Ø 6,0 mm	FBWFS060
Mold Ø 6,3 mm	FBWFS063
Mold Ø 7,0 mm	FBWFS070
Mold Ø 8,0 mm	FBWFS080
Mold Ø 9,5 mm	FBWFS095
Mold Ø 10,0 mm	FBWFS100
Mold Ø 12,0 mm	FBWFS120
Mold Ø 12,5 mm	FBWFS125
Mold Ø 14,3 mm	FBWFS143
Mold Ø 15,0 mm	FBWFS150
Mold Ø 18,0 mm	FBWFS180
Mold Ø 20,0 mm	FBWFS200

V-belts

Mold (Z) 10x6 mm	FBWFS100X060
Mold (A) 13x8 mm	FBWFS130X080
Mold (B) 17x11 mm	FBWFS170X110
Mold (C) 22x14 mm	FBWFS220X140

V-belt special version

Mold 8 x 6,5 mm vaulted top	FBWFS080X065
Mold 10 x 8 mm	FBWFS100X080
Mold 16,35 x 11,3 mm (bluepower)	FBWFS163X113
Mold 17 x 11,3 mm (bluepower)	FBWFS170X113

Timing belts (width max. 50mm, max Finger length 100mm)

Mold for timing belt HTD5	FBWFZHTD5MN
Mold for timing belt HTD8	FBWFZHTD8MN
Mold for timing belt T5	FBWFZT5N
Mold for timing belt T10	FBWFZT10N
Mold for timing belt AT5	FBWFZAT5N
Mold for timing belt AT10	FBWFZAT10N
Mold for timing belt AT20	FBWFZAT20N
Mold for timing belt H (B: 50,8 mm/2")	FBWFZHO
Mold for timing belt L (B: 50,8 mm/2")	FBWFZLO
Mold for timing belt RPP 8M	FBWFZRPP8MN



Mold for timing belt

Belt edge special version

Mold 14x28 mm	FBWFS14X28
---------------	------------

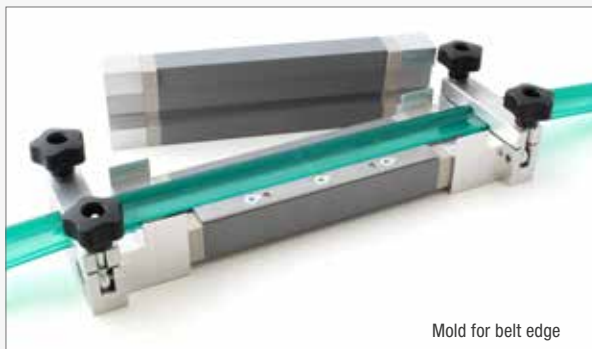

Mold for belt edge



We would be happy to check the realisation for your belt edge profile.

Belt edge profiles can be found on page 84.

SH01

Designed to accurately cut and prepare reinforced profiles for overlap welding with the BEHAbelt HP01 hot press.



Profile adapters for round belts

Order No.	Description	Dimensions (mm)
FBWSH1R060	Profile adapter for round belts	∅ 6,0
FBWSH1R063	Profile adapter for round belts	∅ 6,3
FBWSH1R080	Profile adapter for round belts	∅ 8,0
FBWSH1R095	Profile adapter for round belts	∅ 9,5
FBWSH1R100	Profile adapter for round belts	∅ 10,0
FBWSH1R120	Profile adapter for round belts	∅ 12,0
FBWSH1R125	Profile adapter for round belts	∅ 12,5
FBWSH1R150	Profile adapter for round belts	∅ 15,0
FBWSH1R180	Profile adapter for round belts	∅ 18,0
FBWSH1R200	Profile adapter for round belts	∅ 20,0

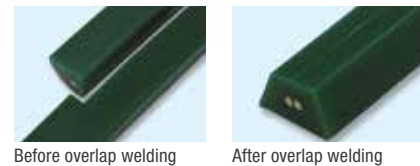

Before overlap welding

After overlap welding

Scope of delivery

- 1 pc. Belt cutter SH01
- 1 pc. Screwdriver
- 1 pc. Profile adapter at your choice
- 1 pc. End wrench
- 1 set Washers

Adapters available for the following profiles:

- Round belts ∅ 6,0 - 20,0 mm
- V-belts 13 x 8 (A), 17 x 11 (B), 22 x 14 (C), bluepower

Dimensions (HxWxD): 200 x 80 x 45 mm

Weight: approx. 1,3 kg

Description

Belt cutter SH01
with 1 profile adapter at your choice

Order No.

FBWSH1

Profile adapters for V-belts

Order No.	Description	Dimensions (mm)
FBWSH1K10	Profile adapter for V-belts	10 x 6 (Z)
FBWSH1K13	Profile adapter for V-belts	13 x 8 (A)
FBWSH1K17	Profile adapter for V-belts	17 x 11 (B)
FBWSH1K22	Profile adapter for V-belts	22 x 14 (C)

Profile adapters for special profiles on request



Profile adapter for round belts



Profile adapter for V-belts

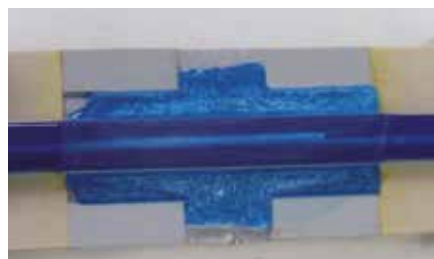

Joining Set CRIMP (steel reinforced)



Carrying bag



CU crimps



Inner and outer welding sleeves are supplied by the metre



Cable stripper cutter



Stripping hook



Crimping tool RH-2



Tutorial video on YouTube

Scope of delivery CRIMP-Set RH-2

- 1 pc. Carrying bag
- 1 pc. Crimping tool RH-2
- 1 pc. Cable stripper
- 1 pc. Stripping hook
- 3m respectively polyester sleeves (outside/inside)
- 100 pcs. CU crimps

Description

Crimp-Set RH-2 \varnothing 9,5 mm
Crimp-Set RH-2 \varnothing 12,5 mm

Order No.

FBWRH2SET095
FBWRH2SET125

Joining Set CRIMP* for steel reinforced profiles with RH-2

This improved crimping technology ensures that the steel-reinforced belt profiles are connected even more reliably.



Canning industry: Crimp Connection

A special design is the connection of belts with steel reinforcement. Here, the exposed reinforcement is connected with press sleeves and the resulting gap in the connection point is then filled again with material inserts/welding sleeves. Using a profile Mold and a hot press, the splice zone is then filled up and welded by pressure and temperature to the rest of the belt.

Our RH-2 joining set is available for this purpose and provides you with the complete equipment and material for creating such a splice.



1
Join exposed reinforcement with press sleeves



2
Fill the gap with material inserts



3
Positioning of the unwelded splice into the Mold



4
Profile joined by hot press

* Ferrules



FZ03/1 & EErgo Z

Overlap welding set consisting of guide unit and EErgo Z

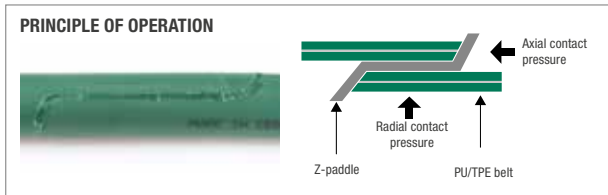

Compact guide unit for overlap welding by means of Z-paddle with vertical and horizontal contact pressure

Product features FZ03/1

- Professional and easy to use guide clamps for overlap welding of reinforced profiles.
- Completely tool-free adjustment of the welding position for welding with Z-paddle.
- Uniform contact pressure over the entire welding surface of the profile for perfect welding quality
- Application range for round belts from \varnothing 6-20mm and for V-belts from 8x5mm to 32x20mm.
- Safe handling with high repeat accuracy of the welding position thanks to toggle lever.
- Scope of delivery includes assembly option with table mounting and vice.
- Unique contact pressure in radial and axial alignment!



Hot paddle welding tool EErgo with Z-paddle

Product features EErgo-Z

- Robust, fibreglass-reinforced and ergonomic handle.
- Special Z-paddle for overlap welding with guide clamp FZ03/1.
- Correct temperature setting thanks to predefined buttons per welding material (PU 280 °C / Polyester 240 °C).
- Precise and stable temperature control for avoidance of temperature fluctuations under different welding conditions
- No adhesion of PU and TPE material thanks to Teflon-coated welding paddle
- Matching magnetic storage stand for safe storage of the welding paddle even when welding in the system

Scope of delivery:

1 pc. FZ03/1-Set (consisting of: FZ03/1, EErgo Z, Storage stand with magnetic base, AS04, SE02, 1 set of clamping pieces of your choice, table mounting, Carrying case, Instruction manual)

Description	Order No.
FZ03/1-Set	FBWFZ03/1B
8,0 kg, approx. 550 x 210 x 350 mm (WxDxH)	

Description	Order No.
EErgo-Z, 115V	FBWEE027
450 g, approx. 210 x 210 x 55 mm (WxDxH)	
Power: 240 W	

Description	Order No.
FZ03/1 Guide Unit	MBWFZ03/1A
3,3 kg, approx. 210 x 250 x 70 mm (WxDxH)	

Spare parts

Spare paddle EERGO-Z

Order No. **FBWEE024**

Dimensions (WxDxH):
approx. 100 x 65 x 6 mm



Overlap welding set with E Ergo-Z

Clamping pieces for FZ03/1

1 set of clamping pieces consists of 2 parts

Features at a glance

- Please note each belt profile requires a matching set of clamping pieces.
- Therefore, please select the appropriate clamping pieces for the required profile geometry.
- **On request, we also manufacture clamping pieces for PU special profiles.**

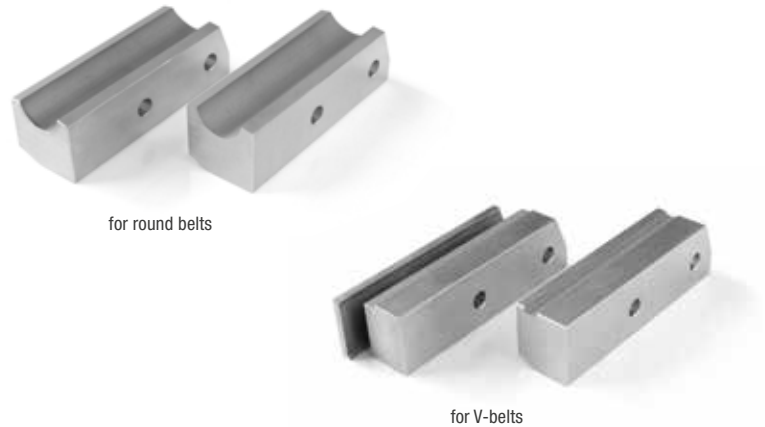

Round belts

Clamping piece for FZ03/1 Ø 6,0 mm	FBWKS1R060
Clamping piece for FZ03/1 Ø 6,3 mm	FBWKS1R063
Clamping piece for FZ03/1 Ø 7,0 mm	FBWKS1R070
Clamping piece for FZ03/1 Ø 7,9 mm	FBWKS1R079
Clamping piece for FZ03/1 Ø 8,0 mm	FBWKS1R080
Clamping piece for FZ03/1 Ø 9,5 mm	FBWKS1R095
Clamping piece for FZ03/1 Ø 10,0 mm	FBWKS1R100
Clamping piece for FZ03/1 Ø 12,0 mm	FBWKS1R120
Clamping piece for FZ03/1 Ø 12,5 mm	FBWKS1R125
Clamping piece for FZ03/1 Ø 12,7 mm	FBWKS1R127
Clamping piece for FZ03/1 Ø 13,0 mm	FBWKS1R130
Clamping piece for FZ03/1 Ø 14,0 mm	FBWKS1R140
Clamping piece for FZ03/1 Ø 14,3 mm	FBWKS1R143
Clamping piece for FZ03/1 Ø 15,0 mm	FBWKS1R150
Clamping piece for FZ03/1 Ø 15,9 mm	FBWKS1R159
Clamping piece for FZ03/1 Ø 17,0 mm	FBWKS1R170
Clamping piece for FZ03/1 Ø 18,0 mm	FBWKS1R180
Clamping piece for FZ03/1 Ø 19,0 mm	FBWKS1R190
Clamping piece for FZ03/1 Ø 20,0 mm	FBWKS1R200

V-belts

Clamping piece for FZ03/1 (M) 8x5 mm	FBWKS1K8
Clamping piece for FZ03/1 (Z) 10x6 mm	FBWKS1K10
Clamping piece for FZ03/1 (A) 13x8 mm	FBWKS1K13
Clamping piece for FZ03/1 (B) 17x11 mm	FBWKS1K17
Clamping piece for FZ03/1 (C) 22x14 mm	FBWKS1K22
Clamping piece for FZ03/1 (D) 32x20 mm	FBWKS1K32

Twin V-belts

Clamping piece for FZ03/1 30x8 mm (TwinA)	FBWKS1K30
---	-----------



In the upper part of the transport bag there is a generally usable space for the die cutter SE02 and free compartments for 9 optional clamping piece pairs.



Robust transport case for the overlap welding set FZ03/1.

HS400 & 800

Specially developed hot paddles for butt welding of conveyor belts. The design of the welding device allows easy and professional handling.



Product features

- HS400 for up to 400 mm belt width
- HS800 for up to 800 mm belt width
- Sophisticated design with positioning aids and stoppers ensures highly repeatable accuracy of weldings
- Clamping lever with locking device
- Robust and handy design of the individual components
- Exact temperature adjustment via control unit
- No adhesion of PU or TPE material due to Teflon-coated heating paddle
- Easy cleaning of the heating blade with a cotton cloth
- Reduced risk of injury during cutting due to practical cutting device
- Welding unit delivered in a mobile, stable transport box for easy use on site
- Smallest weldable belt length $L_f = 800$ mm

HS400S / HS800S

Special design for short belt lengths from $L_f = 500$ mm



Scope of delivery:

1 pc. HS 400-Set (consisting of HS-BOX (incl. power cord US), HS400, FT400, connection cable HS400/HS-Box, EM01 bead remover, insert-bar AL 70°/90°, angle plate 70°/90° and transport case 400)

1 pc. HS 800-Set (consisting of HS-BOX (incl. power cord US), HS800, FT800, connection cable HS800/HS-Box, EM01 bead remover, insert-bar AL 70°/90°, angle plate 70°/90° and transport case 800)

Description

HS400 Welding Set in case
35,0 kg, approx. 50 x 95 x 30 cm (WxLxH)
HS800 Welding Set in case
48,0 kg, approx. 50 x 135 x 30 cm (WxLxH)

Order No.

FBWHS400US
FBWHS800US

Individual components:

HS BOX (Control unit for HS400/800) 1,2 kg, approx. 18 x 20 x 15 cm (WxLxH) Power: max. 3,2 kW, 115V/230V AC	FBWHSB01
HS400 (Heating paddle 400mm) 1,2 kg, approx. 8 x 60 x 17 cm (WxLxH) Power: 2,3 kW	FBWHS400S01
HS800 (Heating paddle 800mm) 1,7 kg, approx. 8 x 100 x 17 cm (WxLxH) Power: 3,2 kW	FBWHS800S01
HS400S (Heating paddle 400mm) 1,2 kg, approx. 8 x 60 x 17 cm (WxLxH) Power: 2,3 kW	FBWHS400S02
HS800S (Heating paddle 800mm) 1,7 kg, approx. 8 x 100 x 17 cm (WxLxH) Power: 3,2 kW	FBWHS800S02
FT400 (Joining table for HS400) 12,5 kg, approx. 28 x 55 x 20 cm (WxLxH)	FBWHS400FT01
FT800 (Joining table for HS800) 20,0 kg, approx. 28 x 95 x 20 cm (WxLxH)	FBWHS800FT01
FT800 (Joining table for HS800, Angle 70°) 20,0 kg, approx. 28 x 100 x 17,5 cm (WxLxH)	FBWHS800FTW1



Robust and easy to use control unit for temperature control



Insert bar for repeatable welds

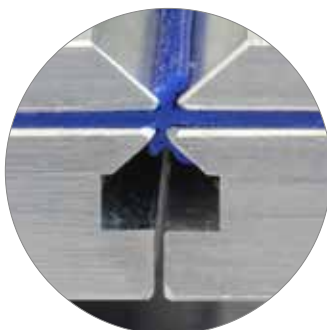

Clamping bars with chamfer for optimum shaping of the welding bead

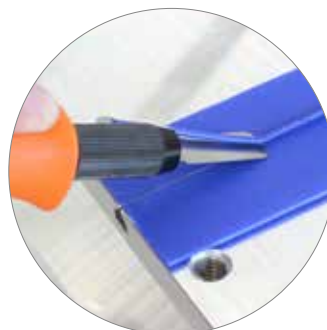

Easy removal of the welding bead with the supplied tool

WELDING TECHNOLOGY FOR ELASTIC MONOLITHIC BELTS

Elastic monolithic PU conveyor belts from BEHAbelt offer new possibilities for joining belt ends thanks to their solid PU belt construction. Thanks to the belt design without reinforcement, finger welding is no longer necessary, as the monolithic belt is a homogeneous belt design – even in the weld seam.

The HS welding device from BEHAbelt is a handy and reliable tool for butt welding monolithic belts. The belts can be joined using 90° or 70° butt splices as required. Depending on requirements, two versions are available with the joining table and heating sword for maximum belt widths of up to 400 and 800 mm.

The simple operation in combination with the intuitive production aids enables repeatable and high-quality joining of the belts.

Optional adapter plates ensure precise positioning and clamping of the belt ends to be welded (e.g. Spike or SuperDrive™) for belts with more complex belt structures.

Angle for straight (90°) and bias (70°) cutting of the belt directly in the welding unit (included in delivery).



Optional 70° joining table for FT800/70° bias butt welds with HS800

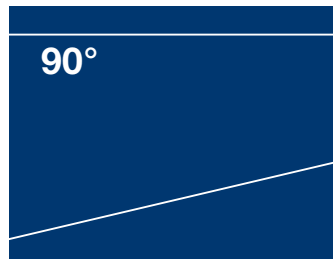

Straight weld with 90° and angled weld with 70° (e.g. for check weighers)

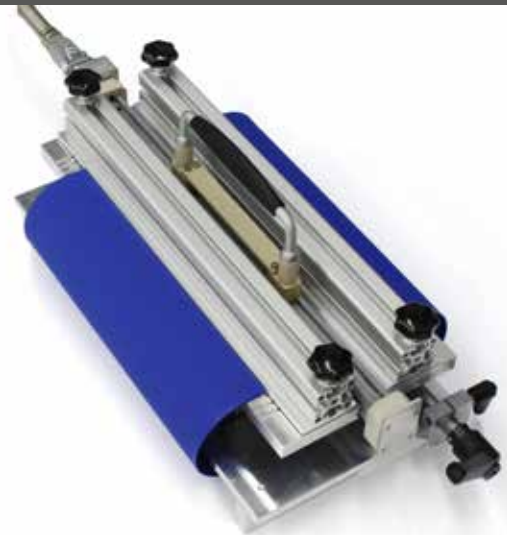

Compact and mobile: The practical HS welding device for conveyor belts



Tutorial video on YouTube

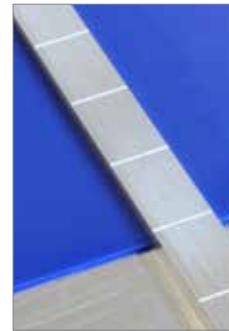

Precise and aligned insertion of the belt ends.

Adapter plates for HS400 & 800

Spike (HS400)	FBWHS4APSP
Spike (HS800)	FBWHS8APSP
AT5 (HS400)	FBWHS4APT5
AT5 (HS800)	FBWHS8APT5
Cleandrive 2", PositiveDrive PD2 (HS800)	FBWHS8APCD
SuperDrive™, CenterDrive CD40 (HS800)	FBWHS8APSD
Thermodrive 2" (HS800)	FBWHS8APTD



Optional adapter plates are available for complex strip structures to ensure optimum alignment and clamping of the belts to be welded in the joining table (not included in the standard delivery programme).

Locking pins ensure that the adapter plates are positioned correctly on the joining table.



RS02-Adapter

Clamping jaw adapter aluminium for friction welding machines RS02 and RS02 AKKU

Description	Order No.
RS02-Adapter Alu	FBWAPRS02A



O-Rings for RS02-Adapter & clamping jaws

O-rings for fixing the clamping jaws and adapters in RS02 and RS02 AKKU

black, rubber, suitable for all RS clamping jaws and adapters

Description	Order No.
O-Rings for clamping jaws (10 pcs.)	MNORING01



Assortment box

Assortment box for clamping jaws for RS02 / RS02 AKKU

with 9 pockets, transparent Box

Description	Order No.
Assortment box	FBWSORT9



Hexagon wrench

for RSX01 Mandrel Welder

For loosening the clamping jaws on the RSX01 Mandrel Welder. Plug-in dimension 7 mm

Description	Order No.
Hexagon wrench	FBWSW7X125



Hexagon torque wrench

RS Hexagon torque wrench 7 / 5 Nm

Description	Order No.
Hexagon torque wrench	FBWSW7/5NM



Protective cap for clamping lever RS02

For external thread of clamping lever on RS02 and RS02 AKKU

Description	Order No.
Protective cap for clamping lever	MFKKB01



Jaws release tool

for pressing out the RS02 clamping jaws

Description	Order No.
Jaws release tool	FBWRSAW01



Battery for RS02

Spare battery for friction welding machine RS02 AKKU

Description	Order No.
RS02 Battery (5 Ah, 90Wh)	FBWRS02A18V5



LG4A Charging unit

Charging unit 4 A / 230V for RS02 batteries (4 Ah and 5 Ah)

Description	Order No.
LG4A Charging unit	FBWRS02LG4A2



EM01 Deburring knife set and spare blades

Knife for removing the welding bead from conveyor belts incl. various replacement blades

Description	Order No.
Deburring knife Set	FBWEM001
Spare blades (10 pcs.)	FBWEM001B12
B 12 mm	



SH01 Spare blade

Spare blade for belt cutter SH01

Description	Order No.
SH01 spare blade	MREKSH01



AS02

Small scissors with prism

90° cut for round belts up to Ø 12 mm.

Description	Order No.
AS02	FBWAS02



AS03

Large scissors with stop

For 90° cuts and mitre cuts.

Description	Order No.
AS03	FBWAS03



AS04

Scissors with angle stop (adjustable)

Scissors with adjustable angle stop

For 45°, 60°, 75°, 90°, 105°, 120° and 135° cuts.

Description	Order No.
AS04	FBWAS04



SE02

Edge cutter with special blade

to remove the welding bead accurately.

Description	Order No.
SE02	FBWSE02



SZ01

Pliers for fitting connectors

Description	Order No.
SZ01	FBWSZ01



Ratched cutter

For cutting very hard plastics e.g. PP, Nylon (PA), TPX, TPEE

Description	Order No.
Mandrel Scissors	FBWRCM01



Paddle (MultiTC)

Spare paddle for profiles
for welding tool „MultiTC“

Dimensions (HxWxD):
35 x 35 x 2 mm

Description	Order No.
Spare paddle MultiTC	FBWMTc1



Paddle (MultiTC)

Spare paddle for flat profiles
for welding tool „MultiTC“

Dimensions (HxWxD):
25 x 70 x 2 mm

Description	Order No.
Spare paddle MultiTC	FBWMTc2



Paddle (SG02/03)

Spare paddle for profiles for
welding tools „SG02/03“

Dimensions (HxWxD):
35 x 35 x 2 mm

Description	Order No.
Spare paddle SG02/03	FBWTC72



Paddle (SG02/03)

Spare paddle for flat profiles for
welding tools „SG02/03“

Dimensions (HxWxD):
22,5 x 75 x 2 mm

Description	Order No.
Spare paddle SG02/03	FBWTC76



Paddle (EErgo 60)

Spare paddle for profiles for
welding tool „EErgo 60“

Dimensions (HxWxD):
43 x 60 x 6 mm

Description	Order No.
Spare paddle EErgo 60	FBWEE002



Paddle (EErgo 90)

Spare paddles for flat profiles
for welding tool „EErgo 90“

Dimensions (HxWxD):
43 x 90 x 6 mm

Description	Order No.
Spare paddle EErgo 90	FBWEE025



Paddle (EErgo-Z)

Spare paddle Z for
paddle welding tool „EErgo“

Dimensions (BxTxH):
approx. 100 x 65 x 6 mm

Description	Order No.
Spare paddle EErgo-Z	FBWEE024



EErgo protection kit

Combustion protection for
stationary operation

Consisting of holder and metal housing

Description	Order No.
EErgo Metal housing	FBWEEZ001
EErgo Holder	FBWEEZ002



KS75

Bench vise with ball joint
for paddle welding tools

Fix your welding tool to facilitate
stationary joining of the belt profiles
easier.

Description	Order No.
KS75	FBWKS75



Storage Stand

Storage stand with magnetic base
for placing of EErgo welding tool

Note: EErgo not included in scope of
delivery

Description	Order No.
Storage stand with magnetic base	FBWEEZ003



Carrying bags

„M“: 28 x 29 x 5 mm
„XL“: 30 x 24 x 11 mm

Description	Order No.
Carrying bag „M“	FCT000000002
Carrying bag „XL“	FCT000000003



Stripping hook for can cable

For processing the CRIMP connection; for pulling off the profile around the steel reinforcement.

Description	Order No.
Stripping hook	FBWAH01



Cable stripper cutter for can cable

90° cut for round belts with steel reinforcement up to Ø 12 mm.

Description	Order No.
Cable stripper	FBWAW01



Cutting adapter HS

For cutting the belts directly in the HS400/800 welding unit. For 70° and 90° butt welding.

Description	Order No.
Cutting adapter	FBWHSSA02



Special heating paddle HS400S/800S

Special design for welding belt lengths from Lf = 500mm

Description	Order No.
HS400S Heating paddle	FBWHS400S02
HS800S Heating paddle	FBWHS800S02



FZ01 knurled nut

Plastic or metal replacement nut (M5)

Description	Order No.
FZ01 nut plastic	MDFZ01001
FZ01 nut metal	MDFZ01002

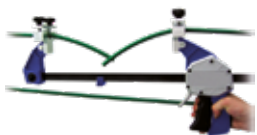

RSH01 & RSH02

Belt tensioning aid with attachment for pre-tensioning round and V-belts.

RSH01 450 mm (18') tensioning distance, suitable for centre distances >1m.
RSH02 900 mm (35') tensioning distance, suitable for centre distances >2 m.

Description	Order No.
RSH01 (450mm)	FBWRSH01
RSH02 (900mm)	FBWRSH02



Insertion bar HS400/800

Robust aluminium bar for precise insertion of the belt ends.

Suitable for 70° and 90° butt welds.

HS400 Insertion bar 400x20x17 mm
HS800 Insertion bar 800x20x17 mm

Description	Order No.
HS400 Insertion bar	MHM00111
HS800 Insertion bar	MHM00112



RSX01

With the RSX01 Mandrel welder, mandrels can be welded quickly and precisely. The welding parameters are optimally matched to the common materials, so that a high repetition accuracy is guaranteed with the simplest operation. As the splice is made by means of frictional heat, no long heating times are necessary.

Features

- Very quick connection of the hose mandrel ends by friction welding
- No danger of burns or fire
- Process reliability due to optimised welding parameters and exchangeable clamping jaws
- Can be used as manual or stationary solution
- Perfect weld joints

EErgo Mandrel

Practical and handy hot paddle welder with predefined temperatures for splicing mandrels made of PP, nylon, TPEE and TPX. The heating time is only 5 minutes and remains constant even with a wide range of ambient temperatures.

Features

- Fiberglass-reinforced ergonomic housing
- Easy operation: 1 Button for PP, 1 Button for Nylon, TPEE and TPX
- Alignment of mandrel ends with a guide clamp
- Ergonomic, user-friendly Design

JOINING TOOLS FOR MANDRELS IN HOSE MANUFACTURING

BEHA Mandrel Welders are specially developed for welding mandrels made of PP, nylon (PA), TPEE and TPX. They are characterised by fast and error-free operation as well as simple and ergonomic handling.

More information: www.mandrel-welder.com



Scope of delivery:

1 pc. RSX01 (115V / 500W), 1 pc. Mounting adapter, 1 pc. Tool for release clamping jaws, 1 pc. Allen socket wrench, 1 pc. Assortment box for clamping jaws, 1 Set Clamping jaw adapter

Description

RSX01 Mandrel Welder 115V

Order No.

FBWRSX12115



Scope of delivery:

1 pc. EErgo Mandrel (115V), 1 pc. Torx wrench, 1 pc. FZ01 Vario (guide clamp, up to Ø 10 mm), 1 pc. FZ02/3 (guide clamp, Ø 10 - 26 mm), 1 pc. Carrying case

Description

EErgo Mandrel 115V / 60mm

Order No.

FBWEE037



KNOW-HOW

PU and TPE material properties.....	121
Cleaning of profiles and belts.....	121
Chemical characteristics of PU and TPE	122
General directives for plastics with direct food contact.....	123
Pulley and drum design.....	124
Guiding concepts AT5.....	127
Pretension and tensioning devices	128
Calculations profiles and belts	129
Table with coefficient of friction.....	130
Quick guide for belt calculation.....	131
Table with manufacturing tolerances.....	133
Technical request	134

Polyurethane and polyester conveyor profiles and belts

- High tensile strength
- Excellent wear and abrasion resistance
- High resilience, low level of belt stretching
- Resistance to oil, grease, dirt and most chemicals
- Temperature resistance from -30°C to +60°C / -22°F to +176°F (dynamic)
- High coefficient of friction
- Silent running
- Excellent weldability
- Hydrolysis resistant
- Hygienic and easy to clean
- FDA/EC compliant



Cleaning of profiles and belts

Cleaning agents and interaction with PU belts

In the food industry, four main groups of cleaning agents are used: neutral, alkaline, acidic and chlorinated. The food manufacturer is responsible for selecting the optimum cleaning method and detergent. We will be pleased to advise you on all questions concerning the selection and suitability of conveyor belts for your production process.

Detergent group	Application	Compatibility with PU conveyor belts and profiles
Neutral	Suitable for many applications, good release properties against fats and proteins	durable
Alkaline	Suitable for the removal of carbohydrate, fat and protein deposits	durable
Acidic	Removal of inorganic components such as salts, calcium and lime deposits	durable
Chlorinated	Removal of stubborn organic residues such as proteins, carbohydrates and discolorations	not recommended

The test results have been determined under laboratory conditions and therefore only provide an indication of the chemical resistance.

Typical cleaning steps

A successful cleaning depends on 4 factors, whose mechanism of action is described in the professional world under the name 'Sinner's Kreis':

- Mechanical energy (cleaning process or method)
- Chemical energy (detergents)
- Temperature (varies depending on contamination between cold and 60°, in exceptional cases food contact surfaces are rinsed with hotter water, but this is not the rule)
- Time (contact time of the detergents or disinfectants)

The cleaning of contact surfaces in contact with the product in the food industry comprises the following work steps:

1. pre-cleaning (removal of coarse impurities, often manually)
2. pre-rinse (to loosen stuck dirt if necessary)
3. cleaning (application and action of the cleaning agent)
4. rinse off
5. check cleaning result
6. disinfection
7. final rinsing



Chemical characteristics of PU and TPE



General

Thermoplastic material can be used in a variety of applications where there is interaction with various chemicals.

Chemical resistance depends on the period of exposure, the temperature, the quantity, the concentration and the type of the chemical substance. It is therefore difficult in any case to make a clear distinction between the effects described below. In the case of chemical degradation of polyurethane the chemical reaction results in cleavage of the molecular chains. In the course of degradation, polyurethane loses strength, and in extreme cases this can lead to disintegration of the part.

For critical applications, a detailed resistance test considering both swelling and the affect on mechanical properties is recommended.

Swelling

Swelling is the fundamental physical process of the absorption of liquid substances by a solid. In this process, the substance enters into the material without chemical interaction.

This results in an increase in volume and weight with a corresponding reduction in mechanical values. After evaporation a reduction in swelling occurs and the original properties of the product are almost completely restored.

Swelling is a reversible process. By using reinforcements in the polyurethane, for example polyester or aramid cords, you can almost avoid this mechanical impact on the material.

Hydrolysis resistance

If polyester-based polyurethanes are exposed for lengthy periods to hot water, moisture vapour or tropical climates, an irreversible breakdown of the polyester chains occurs through hydrolysis. This results in a reduction in mechanical properties. This effect is more marked in flexible grades, where the polyester content is correspondingly higher than in the harder formulations.

Degradation of polyester-based polyurethanes is however rarely experienced at room temperature. Because of its chemical structure, polyester-based polyurethanes are much more resistant to hydrolytic degradation.

Microbiological resistance

When using polyester-based thermoplastic polyurethane under climatic conditions of high heat and humidity, parts can be damaged by microbiological attack. In particular, microorganisms producing enzymes are able to affect the molecule chains of polyester-based TPU.

The microbiological attack initially becomes visible as discoloration.

Subsequently, surface cracks occur which enable the microbes to penetrate deeper and to cause a complete destruction of the TPU.

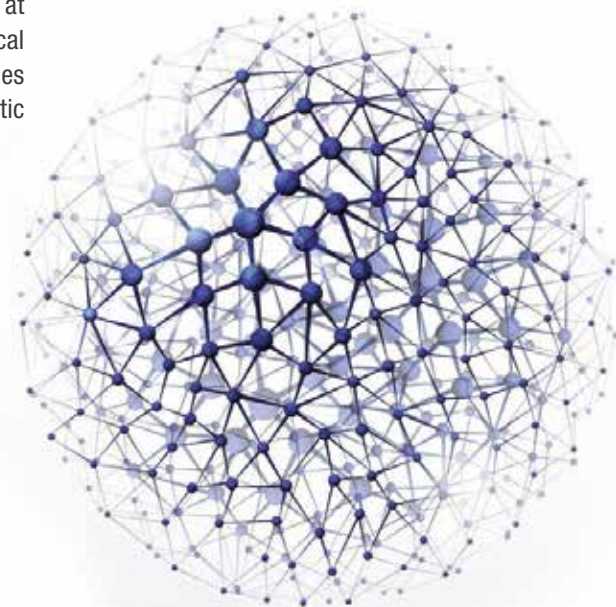

General directives for plastics with direct food contact

There are several country-specific and global directives for the application of food contact materials. In general, all food contact materials have to be produced according to the principles of Good Manufacturing Practice (avoiding the occurrence of a health hazard or any other unacceptable change in the composition of the food during its intended use).



FDA Guideline "Title 21: Code of Federal Regulations"

The Food and Drug Administration of the Public Health Service of America is the world's best-known authority involved in consumer protection in respect of potential detrimental influences. The FDA has prepared a review "Title 21: Code of Federal Regulations" in respect of their approval of raw materials in a processed or finished state, and also specified the conditions under which the approval is valid.



EC Directive 1935/2004, EU Directive No. 10/2011

The framework Regulation EC 1935/2004 (EU Directive No. 10/2011) Food Contact and belonging specific Directive 2002/72/EC Monomers Additives of the European Parliament regulates plastics intended to come into contact with foodstuffs. The EU legislation for food contact materials is based on positive lists of the substances and maximum limits of migration into food. Only substance on these positive lists may be used for manufacturing plastics that are designated to have food contact. Further-

more, you have to show the evidence of the global and specific migration. This can be requested and interpreted differently depending on the application.



Risiken erkennen – Gesundheit schützen

Federal Institute for Risk Assessment (BfR) recommendation „Plastics in the foodstuff chain“

The Federal Institute for Risk Assessment (previously the Federal Institute for Consumer Health Protection and Veterinary Medicine (BgVV)) was formed to increase the health protection of consumers and processes scientific recommendations and recognized orientation aids for possible health risks through materials that come into contact with foodstuff. These recommendations are listed in the „Recommendations within the framework of the German Food and Feed Code (LFGB)“.



USDA

The official United States Department of Agriculture is a part of the Federal Government of the United States of America. In addition to checking the use of raw materials in accordance with the FDA, the USDA also checks the suitability of the finished product (belt/conveyor) with regard to the cleanability of the product constitution (surfaces). Conformity in accordance with the USDA is primarily required for equipment in the processing of meat, poultry and milk in the United States of America.

HACCP concept

The Hazard Analysis and Critical Control Points concept (abbreviated: HACCP concept or HCCP concept) is a tool clearly aligned for structured and preventive measures. It is used to prevent risks in conjunction with foodstuff that can result in the consumer becoming ill.

This concept was developed around 1960. In German law, the HACCP concept was initially anchored into the Foodstuff Hygiene Ordinance from 1998. The EC Ordinance 852/2004 also provides for mandatory application of the HACCP concept in all companies engaged in the production, processing and sales of foodstuff.

The hygiene package accepted by the EU in 2004 came into force on the 1st January 2006. Herein, it is decreed that only foodstuff conforming to the directives of the HACCP must be handled and introduced into the Union.

Principles of the HACCP:

1. Carrying out a risk analysis
2. Identification of the critical checking points that the foodstuff is safe
3. Determining the intervention limits at the respective critical checking points
4. Establishing applicable monitoring procedures on the critical checking points
5. Establishing corrective measures in the event of deviations
6. Establishing assessment measures for checking the efficiency of the HACCP system determined
7. Establishing documentation of the measures



„What impact has the pulley diameter on the belt?“

The minimum pulley diameters are to be selected according to the values given in the tables. These have been chosen according to the material quality (Shore hardness) due to the relatively low transport speed - from experience less than 2m per second. Since the goods are pulled, the drive pulley should be provided at the end of the transport path. The geared motors should always be equipped with a soft start or frequency converter.

The diameter of the pulley has a significant effect on the life (service life) of the belt. The specified minimum pulley diameters in mm should not be undercut, but rather chosen somewhat larger. Pulley diameters that are too small always have a detrimental effect on the service life, as extreme bending cycles lead to material fatigue. The specified minimum pulley diameters always refer to a wrap angle of 180°. The wrap angle indicates how many degrees the belt is guided around the pulley.

Recommended pulleys for round belts

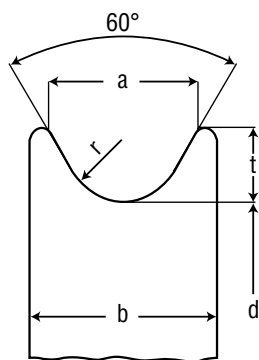

Belt Ø	2	3	4	4,8	5	6	6,3	7	8	9,5	10	12	12,5	15	18	20
a (mm)	4,5	5,5	7	8	8	10	10	11	12	14,5	15	18	18,5	23	28	30
b (mm)	6,5	8	10	12	12	14	14	15	16	19	19	22	23,0	27	32	36
t (mm)	2,5	3	3,5	4	4	5	5	5,5	6	7	7,5	9	9	12	14	15
r (mm)	1,4	1,9	2,5	3	3	3,5	3,5	4	4,5	5,5	5,5	6,5	7	8	9,5	11

Please select the appropriate minimum pulley diameter according to the different PU/Polyester qualities. The best qualified materials for pulleys are steel, high-alloyed steel, aluminium or Polyamid when it comes to plastic. Please keep in mind the low friction coefficient μ when using plastic material.

Pulleys for V-belts

Profile according to DIN 2215	6	8	10	13	17	22	32
Global standard acc. to ISO 4184	Y	M	Z	A	B	C	D
Upper width b (mm)	6	8	10	13	17	22	32
Height h (mm)	4	5	6	8	11	14	20
Lower width u (mm)	3,3	4,55	5,9	7,5	9,4	12,35	18,25
Pulley angle α	$\angle 34 - 38^\circ$						
Groove width b1	6	8	10	13	17	22	32
Groove depth t (mm)	→ depending on how much the profile should stick out above the upper pulley edge $h + 2,0 \text{ mm}$						

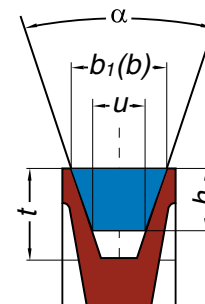

For BEHAbelt V-belts according to DIN 2215 / ISO 4184 pulleys for V-belts according to DIN 2217/ISO 4183 have to be used.

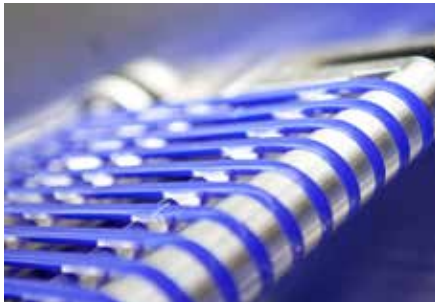

Design of pulleys for belt profiles

Considering the pairing of belts and pulleys it is generally recommended to work with materials and/or surface that create sufficient friction to PU/TPE e.g. Aluminium or Steel. This is important to ensure proper power transmission. Beware that Aluminium can lead to discoloration (blackening) of belts. All other pulleys, guiding elements or slider beds should be made of low-friction materials for example PE or HDPE.

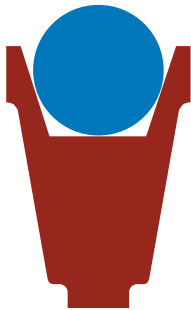

Grooved pulleys for round belts

In practice, V-belt pulleys are often used for round belt applications. You should know that this is not an optimal geometry pairing and should therefore be changed to a special round belt pulley if possible.

In addition to typical faster wear of the belt in the flank contact points, a V-belt pulley in this case can also cause the round belt to jam between the flanks of the pulley, which in turn can lead to additional stretching as well as „fluttering or jumping“ of the belt. Under these conditions, the service life of the belt is basically reduced. If V-belt pulleys are nevertheless used, the pulleys must be dimensioned so that the belt also makes contact with the base of the pulley.



Pulleys for T-Profiles

The power-transmission of such belts takes place on the flat area of the belt reverse side. This means the V-guide is not an element to transmit power but has guiding purpose only. Hence, the guide should run free in the groove with little space and must never be clamped!



Pulleys for Twin V-belts

With twin V-belts, a distinction is made between the use as a drive conveyor belt or as spreader belt.

In the case of a drive, the pulley design must be in such a way that the power is transmitted by the flanks.

In spreading table applications, it has proved to be a good idea to guide the belt exclusively by the central groove and drive it by the underside of the profile.



Belt pulleys for V-guide for belts

The power transmission of belts takes place via the running side. This means that the centrally positioned V-guide only serves to guide the profile.

The V-guide must therefore be considered free-running in the belt pulley design. Clamping of the V-guide should be avoided.



Guide rails and supporting rollers

Grooved pulleys, supporting rolls and guide rails are recommended to keep the belting in position to carry the load. When guiding V-belts, the V belt groove should be designed so that the belt is being supported on the bottom of the groove and is only allowed to touch one side of the groove at a time to avoid jamming.

The diameter and number of the required supporting rolls depends on the length of the conveyor as well as on the weight and

dimensions of the goods to be conveyed. Supporting guide rails with a smooth surface can be grooved to support transport belts. The dimensions of the groove are to be designed in a width that prevents the belt from jamming. The guiding rails should be made of materials with good sliding qualities (PE – HDPE). If you are looking for a supplier please contact us, we can give you a recommendation.

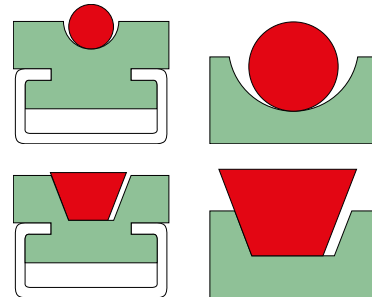

Drum design for conveyor belts

Crowned pulleys

To prevent the flat belts from slipping, at least one of the pulleys must be crowned, preferably the larger pulley or the one with the largest contact angle.

Commonly available pulleys are crowned in accordance with ISO 22. The larger the contact angle, the better the tracking effect for the belt.

In practice, the typical design of a crowned pulley is applied in three equal parts (conical/cylindrical/conical) based on the total drum length.

Pulley width

The width of the pulleys should be at least 1.05 to 1.1 times the belt width. In principle, we recommend that half of the belt width be cylindrical and conical towards the outside.

Drum surface

Clean and smooth running surfaces increase the efficiency and service life of conveyor belts.

The running surface of drive pulleys must not be too smooth or too rough (no knurled surfaces!) as this can lead to excessive belt wear, noise and premature belt failure.

We recommend to manufacture running surfaces with a roughness of $R_a = 1,6 \mu - 3,2 \mu - 6,3 \mu$.

Drive pulley design conveyor belt: Calculation

Length of cylindrical area b_c

$$b_c = b_0 / 2$$

Pulley width b

$$b = b_0 \times 1,1$$

Crown bow h

$$h = (d + 100) / 450 \text{ mm}$$

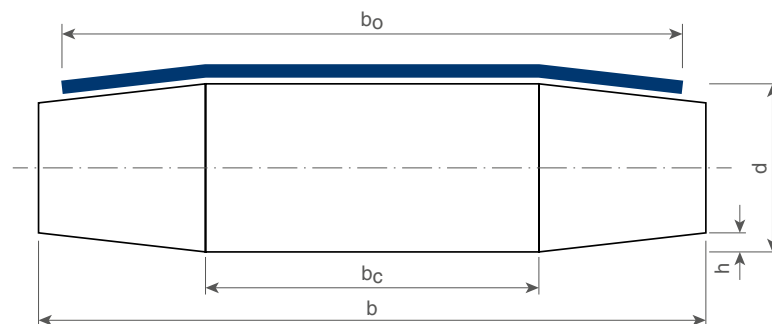

As a rule, machine designers traditionally use a drum design with the pitch 1/3 / 1/3 / 1/3. However, the 1/4 / 1/2 / 1/4 pitch has proven to be particularly suitable for soft belt types.

Introduction guiding concept for AT5

The interaction of AT5 drive with optimal belt guidance ensures track stability and slip-free drive. The preferred design for the belt guide takes into account a combination of guide groove in the belt and guide bar for the pulleys.

The position and number of guide grooves can be adapted to the requirements and conditions of the conveyor.

Several guide grooves basically increase the guide stability of the belt, whereby the arrangement of the guide grooves should preferably be centered in the middle of the belt and in the inner third of the belt width. Guide grooves near the outer edges of the belt are not recommended.

For cost reasons but also to simplify the implementation of the belt guiding concept, usually only the non-driven belt pulleys are designed as smooth rollers with guide bars, while the AT5 drive usually does without guide elements.

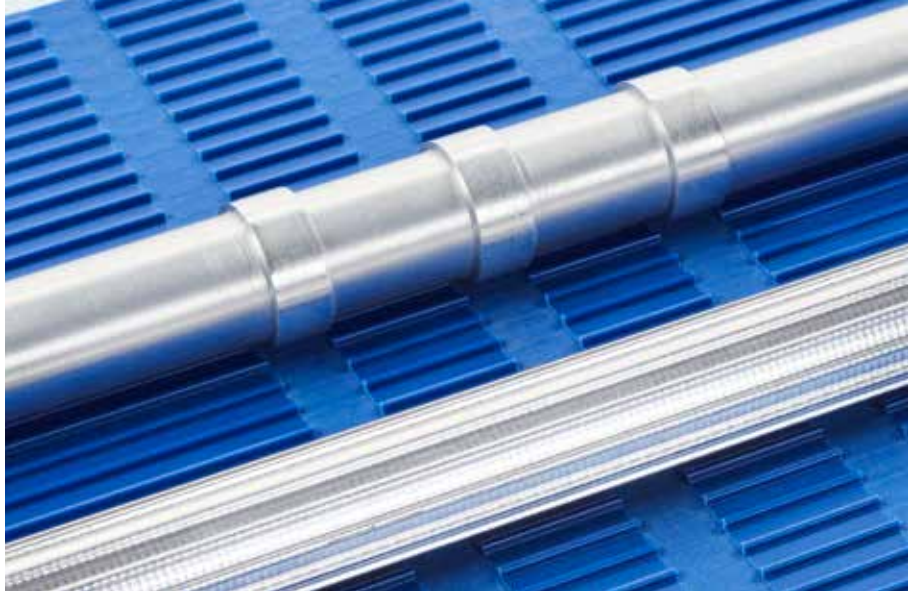

Typical design versions of the guide grooves in the belt are, for example, a groove width of 5 mm with a bar width of 15 mm between the grooves or a 10 mm groove with a bar width between the grooves of 20 mm. Depending on the belt width used, we recommend one to three guide grooves up to

a belt width of 300 mm and three to seven guide grooves from a belt width > 300 mm. In case of possible transverse loads on the belt, it is better to increase the number of guide grooves.

Design of the guide grooves in the conveyor belt

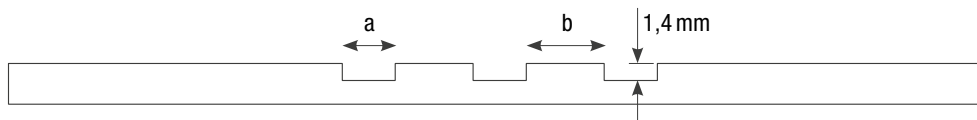

Design of the guide bars on the pulley

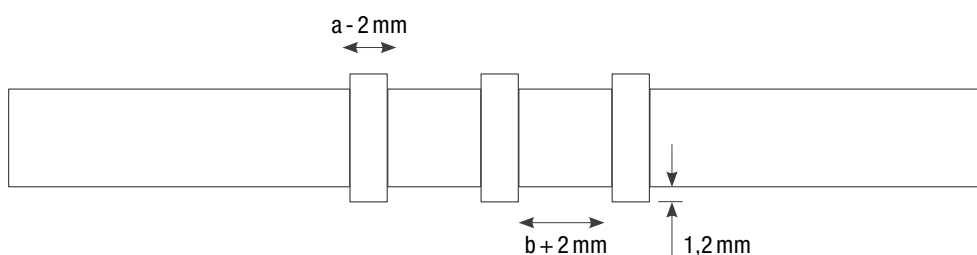

Pretension and tensioning devices

Pretension

To ensure that the conveyor system works reliably, the belts must be sufficiently pre-tensioned.

We therefore recommend a pre-tensioning factor of approx. 0.5–10%, depending on the belt quality (Shore hardness), belt design (with/without reinforcement), connection technology (splice/overlap) and belt length.

To determine the pretension in the belt, it has proven effective in practice to mark the belt in a tension-free state and measure the change in length of the markings.

For example, a marking of 1000 mm changes to a marking distance of 1060 mm under a pretension of 6%.

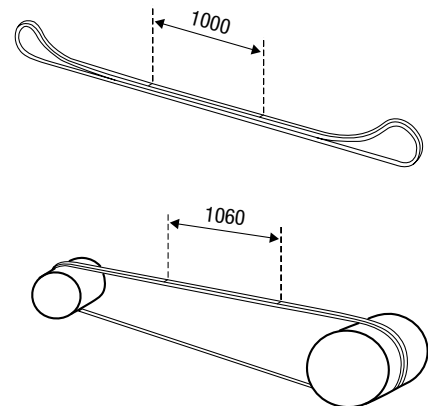

How does the pretension of a belt impact its lifetime?

The proper pre-tensioning of the belt is just as critical for belt performance as selecting the right belt and the right splicing system. For the recommended pretension please refer to the product tables of each belt in this delivery program.

Effects of wrong pretension:

Too low pretension results in slippage of the belt which generates excessive heat. This causes belt deformation, heavy abrasion, breaking and jumping out of the pulley.

Too high pretension may cause damage to pulleys, shafts and bearings. The belt permanently is over-tensioned and will prematurely fail due to material fatigue and formation of cracks. Furthermore the belt loses its material resilience.

Tensioning devices

A variety of tensioning devices can be used to accommodate the different amounts of stretch in belts or to make the installation process easier. In addition, for reinforced belts or belts with little pretension required, we recommend the use of tensioning devices permanently installed on the conveyor system. Please follow our recommended pretension for each belt to reduce premature wear and failure on your bearings. Common ways to properly tension a belt are as follows:

- cut the belt to a shorter length than the measured length of the conveyor system
- use a take up pulley or a deflection pulley with a counter weight or a mechanical screw movement
- the drive motor is moved in slotted mounting holes via an adjustment screw
- tensioning sled (the drive motor is mounted on rails and is moved by its own weight or by a screw mechanism)
- tensioning jack (the motor with the drive pulley is mounted on a turnable rocker. If the drive motor is running in the specified direction the backwards engine torque tension the belt automatically)

The right positioning of tensioning pulleys is essential for the lifetime and functionality of a belt. The tensioning pulleys always should be located in the return strand right after the drive pulley.

Working out the correct belt length

Use a string or steel tape to make measurements after reducing take-up (if installed) to the minimum. Distance between pulleys should remain fixed. To obtain good driving strength and good belt life, the belt pretension should be 0,5% to maximum 10%, based on hardness and length of the belt.

To verify pretension on an installed belt, apply two marks with a pen separated by 10 inches (or 100 mm) on the belt when it is free from tension. The increase of space between the marks after mounting the belt in tenths of an inch (or mm) provides a measure of the pretension in percent.

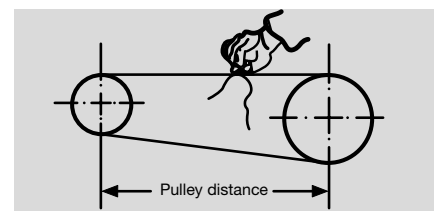

Calculation of belt length

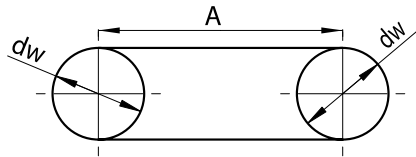

$$L_{f1} = dw \times \pi + 2 \times A$$

dw = effective diameter
(position of the neutral fiber of belt)
A = center distance
for round belts:
dw = d bottom of groove + diameter of belt

The recommended pretension has to be considered in addition!

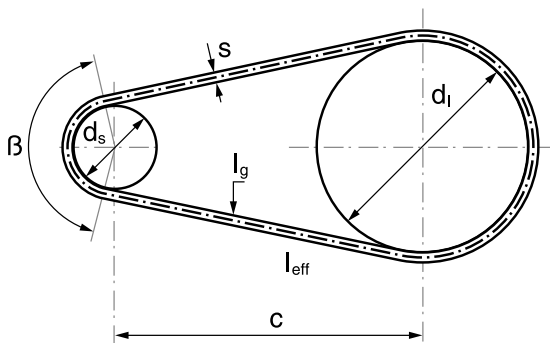

$$L_{eff} = 2c \cdot \sin\left(\frac{\beta}{2}\right) + \frac{\pi}{2} \left[d_s + d_i + 2s + \frac{(d_i - d_s)(180 - \beta)}{180} \right] \text{ [mm]}$$

$$\beta = 2 \arccos\left(\frac{d_i - d_s}{2c}\right) \text{ [}^\circ\text{]}$$

c = center distance [mm]
ds = Diameter of the small pulley [mm]
di = Diameter of the big pulley [mm]
β = Wrapping angle on small pulley

The recommended pretension has to be considered in addition!

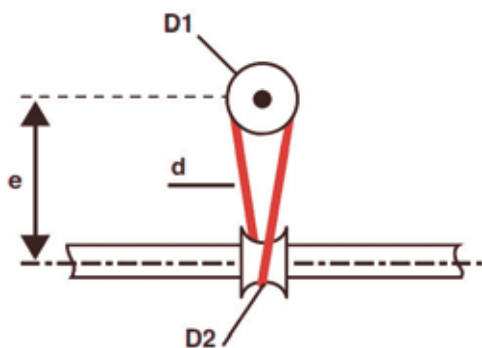

Lineshaft conveyor belts (semi-crossed)

$$L_{f3} = [(D1 + d) + (D2 + d)] \times \pi / 2 + 2 \times \sqrt{[(D1 + d)^2 / 4 + e^2]}$$

recomm. center to center distance: $4 \times D1$

D1 : pulley diameter at bottom of groove
D2 : inner diameter of diablo roller
d : diameter of belt
e : center distance

The recommended pretension has to be considered in addition

Auxiliary table / Quick reference for V-belts

Profile according to DIN 2215		6	8	10	13	17	22	32
Profile according to ISO 4184		Y	M	Z	A	B	C	D
Upper width b (mm)		6	8	10	13	17	22	32
Height h (mm)		4	5	6	8	11	14	20
Calculation of the belt length La and Lw, if Li is determined or known	La = Li +	25	31	38	50	69	88	126
	La = Lw +	10	12	16	20	29	30	51
La = outside length	Lw = Li +	15	19	22	30	40	58	75
Lw = effective length / cut length	Lw = La -	10	12	16	20	29	30	51
Li = inside length								

The recommended pretension has to be considered in addition

Coefficient of friction μ for smooth surfaces (G)

Quality	Alu	Steel	Glass	Wood (veneer)	PE	HDPE
PU40A	1,35	1,30	1,10	1,10	0,85	0,80
PU60A	0,95	0,90	0,75	0,80	0,55	0,50
PU65A	0,90	0,85	0,65	0,70	0,50	0,45
PU70A	0,85	0,75	0,60	0,70	0,40	0,35
PU75A	0,85	0,70	0,50	0,65	0,40	0,35
PU80A	0,80	0,65	0,45	0,60	0,35	0,30
PU85A	0,75	0,60	0,40	0,50	0,35	0,30
PU85A rough	0,55	0,45	0,45	0,45	0,30	0,25
PU90A	0,70	0,50	0,30	0,50	0,30	0,25
PU95A	0,65	0,45	0,25	0,45	0,25	0,20
TPE40D	0,70	0,50	0,30	0,45	0,25	0,20
TPE55D	0,45	0,35	0,30	0,35	0,20	0,15
TPE63D	0,45	0,35	0,30	0,35	0,20	0,15

Coefficient of friction μ for flat belt surfaces on steel (dry)

Quality	smooth gloss (SG)	smooth matt (SM)	fabric impression (FI)	rough impression (RI)	Diamond (ID)	Slightly rough (SR)
PU40A	1,50	1,40	1,35	1,40	1,30	1,35
PU60A	1,00	0,90	0,85	0,90	0,80	0,85
PU65A	0,85	0,80	0,70	0,75	0,65	0,70
PU75A	0,70	0,65	0,55	0,50	0,50	0,55
PU80A	0,65	0,60	0,50	0,40	0,45	0,50
PU85A	0,60	0,55	0,45	0,35	0,40	0,45
PU90A	0,65	0,60	0,50	0,40	0,45	0,50
PU95A	0,45	0,40	0,30	0,20	0,25	0,30
PU55D	0,35	0,30	0,25	0,15	0,20	0,25
TPE40D	0,45	0,40	0,30	0,20	0,25	0,30
TPE55D	0,35	0,30	0,25	0,15	0,20	0,25

V-belt dimensions according to DIN 2215 and ISO 4184

All V-belts are produced with a small radius at the edges

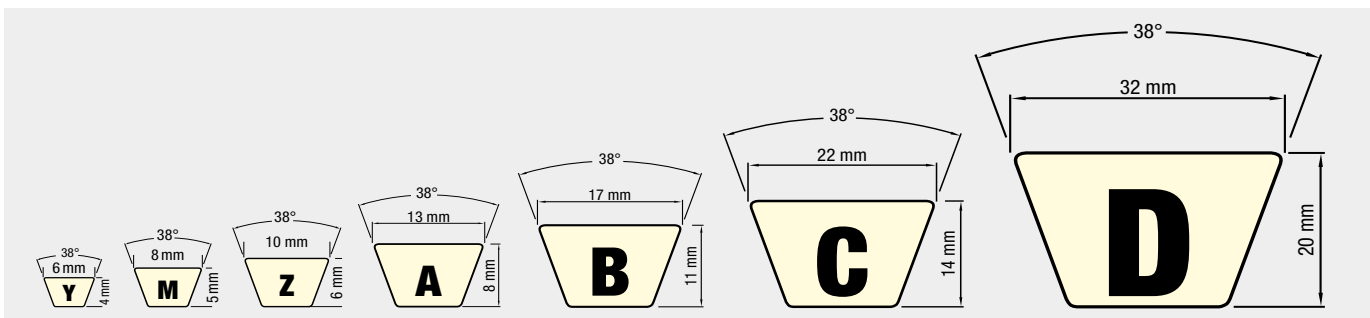

Calculation of round belt and V-belt cross section

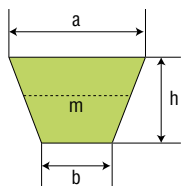

$$A_{cm^2} = \frac{a+b}{2} \times h = m \times h$$

$$m = \frac{a+b}{2}$$

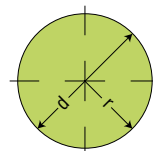

$$A_{cm^2} = \frac{\pi}{4} \times d^2 \approx 0,785 \times d^2$$

$$U = \pi \times d$$

Quick guide for belt calculation

The following three formulas provide information on the most important parameters for the design of a conveyor belt. With the help of these formulas, you can quickly and easily determine the pretension force, axle load and theoretical max. transport weight.

Of course, our experienced technical team will be happy to assist you. We look forward to your enquiry. Phone: +49 7684 907 0

Support

Which variables influence the values to be calculated?

Preload/axle load:

▲ Increase pretension

- + More power transmission
- + Less slip
- Increased axle and bearing load
- Increased Amp draw (motor)

▼ Reduce pretension

- + Less axle and bearing load
- + Less power consumption (motor)
- Increased slip/abrasion
- Belt tracking and alignment not guaranteed

k1% (Belt thickness and/or hardness)

▲ Increase k1%

- + Higher transport weight
- + Mechanically more robust
- Greater redirection
- Increased axle and bearing load
- Increased pretensioning force; Belt tensioner may be necessary

▼ Reduce k1%

- + Smaller redirection
- + Lower axle and bearing load
- Reduced transport weight
- Mechanically more susceptible

Reduce coefficient of friction (μ)

- ▶ Compared to steel, HDPE or PE substrates offer significantly lower friction resistance.
- ▶ Friction - optimized belt surfaces (e.g. rough, diamond, etc.) also reduce the coefficient of friction due to their smaller contact area.

PRETENSION FORCE (N)

$$k1\%_{\text{stat.}} \text{ (N/mm)} \times \text{belt width (mm)} \times \text{pretension (\%)} \times 2$$

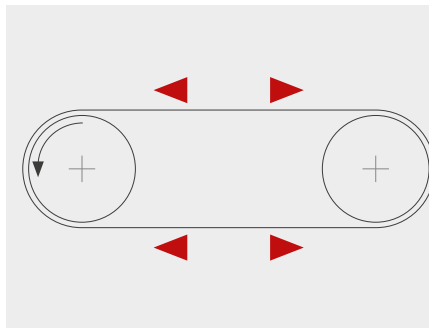

How much force (F) must be applied to pre-tension the belt?

What values are needed for this?

AXLE LOAD (N)

$$k1\%_{\text{stat.}} \text{ (N/mm)} \times \text{belt width (mm)} \times \text{pretension (\%)} \times 2$$

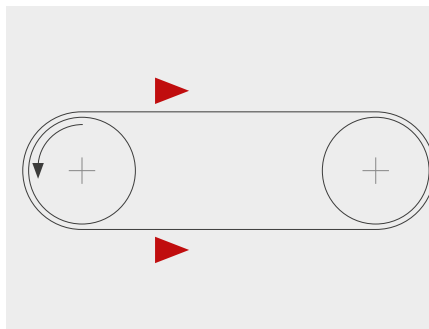

How much force (F) is applied to the axles due to the belt dimension?

How can the axle load be influenced (pretension, strength of the belt, hardness)?

MAX. TRANSPORT WEIGHT (KG)

$$k1\%_{\text{relax.}} \text{ (N/mm)} \times \text{belt width (mm)} \times \text{pretension (\%)} \times 0,1 / \text{coefficient of friction (\mu)}$$

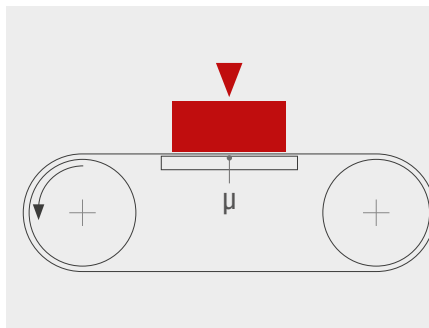

How much weight (kg) can be transported?

What is needed to calculate this?

K1% (N/mm): Modulus of elasticity of the respective conveyor belt (elasticity constant). This value indicates how much force (N) per unit of belt width (mm) is required to stretch a belt by 1 %.

Belt width (mm): Functional width of the conveyor belt

Coefficient of friction (μ): Sliding coefficient of friction (in motion) between belt surface and contact surface of the belt support.

Pretension (%): Selected belt pretension of the elastic monolithic belts to create a frictional connection (force transmission without slip) between belt and drive element.

Explanations of the various influencing variables for belt design

Elasticity modulus $k1\%$



Based on the ISO 21181 standard, the $k1\%$ value (N/mm) defines the modulus of elasticity for conveyor belts. It shows how much force in Newtons per unit of belt width (mm) is required to stretch a belt by 1%.

In other words, how much (in %) must a belt be stretched to achieve a certain force on the drive drum.

In practice, two different $k1\%$ values ($k1\%$ static, relaxed) are used.

The static value acts immediately when the belt is mounted and thus represents the elasticity behaviour of the belt before it is used and before the usual running-in of the belt. The relaxed value represents the stabilised change in the elasticity behaviour after the belt has been run in (according to the 24h standard).

This also results in the respective use of the two $k1\%$ values: Whereas the static value is relevant for the calculation of pre-tensioning forces and bearing loads, the relaxed value is used for the calculation of the max. transport weight or the max. force transmission.

Coefficient of friction (μ)

The coefficient of friction is indicated with the formula symbol " μ " and serves as a measure of how high the frictional force acts between two materials (sliding friction). However, this always serves only as an approximate indication. The friction force depends on many different factors and is often influenced and changed during the operation of the installation due to changing environmental conditions.



The effect of the briefly acting higher coefficient of friction during start-up (is approx. 1.3 to 1.8 times the dynamic coefficient of friction) is usually taken into account in the system design via the safety factor selected by the designer.

Pretension (%)

For the trouble-free running of elastic monolithic belts, a correct and sufficient pretension is required to ensure the transmission of force without slippage. The pretension must be adjusted according to the technical task and to possible influences (temperature, contamination, ambient humidity, etc.).

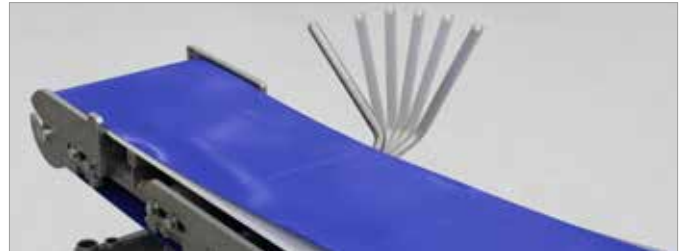

For drives without a tensioning option, the correct pretensioning must be taken into account during production by shortening the belt length.

The belt tension is directly related to the running behavior. If the tension is too high, the running behaviour will be unstable and machine components such as bearings and shafts will be subjected to high stress. Too little tension leads to slippage and abrasion on the drive pulley and possibly also to the loss of the belt centring function with crowned rollers.

Due to the already described shrinkage of the belt – represented by the values $k1\%_{\text{stat}}$ and $k1\%_{\text{relax}}$ – the belt pretension is reduced to the same extent and may have to be retensioned accordingly or, if not possible during assembly, designed to be larger.

Since this is an elastic monolithic belt construction, the pretension of the belt can only be increased to a limited extent. Otherwise, a permanent deformation and thus a belt elongation will be caused. This max. belt pretension is specified by the manufacturer in the data sheet and represents the elastic working range of the conveyor belt.

Belt width (mm)

The belt width is proportional to the force required to stretch the belt. The wider a belt, the greater the force required to stretch the belt, i.e. wider belts generally require smaller pretension values (%) than narrower belts.



Manufacturing tolerances BEHAbelt round- and V-belts/conveyor belts

Description	Dimension mm		Tolerance ≈ mm
Round belts			
Type PU75A / 80A	∅ 2 - ∅ 8		± 0,2
Type PU75A / 80A	∅ 9 - ∅ 15		± 0,3
Type PU85A / 90A / 95A	∅ 2 - ∅ 8		± 0,2
Type PU85A / 90A / 95A	∅ 9 - ∅ 15		± 0,3
Type PU85A / 90A / 95A	∅ 18 - ∅ 20		± 0,5
Type TPE40D / 55D	∅ 3 - ∅ 8		± 0,2
Type TPE40D / 55D	∅ 9 - ∅ 15		± 0,3
Type TPE63D	∅ 6,3, ∅ 9,5, ∅ 12,5		± 0,3

Round belts can be produced on request in "-" or "+"-tolerance.

Description	Dimension mm	(ISO)		Tolerance ≈ mm	
V-belts DIN 2215				0-Width	Height
Type PU65A	6 - 8 - 10 - 13 - 17 - 22	(Y - M - Z - A - B - C)		- 0,5	+ 0,5
Type PU75A	6 - 8 - 10 - 13 - 17 - 22 - 32	(Y - M - Z - A - B - C - D)		- 0,5	+ 0,5
Type PU80A	6 - 8 - 10 - 13 - 17 - 22 - 32	(Y - M - Z - A - B - C - D)		- 0,5	+ 0,5
Type PU85A	6 - 8 - 10 - 13 - 17 - 22 - 32	(Y - M - Z - A - B - C - D)		- 0,5	+ 0,5
Type PU90A	8 - 10 - 13 - 17 - 22 - 32	(M - Z - A - B - C - D)		- 0,5	+ 0,5
Type TPE40D	8 - 10 - 13 - 17 - 22	(M - Z - A - B - C)		- 0,5	+ 0,5
Type TPE55D	8 - 10 - 13 - 17 - 22	(M - Z - A - B - C)		- 0,5	+ 0,5

Description	Dimension mm		Tolerance ≈ mm
Flat belt			
Profile thickness	0,9 / 1,0 / 1,2 / 1,6 / 2,0 / 3,0 / 4,0		+ / - 0,1

Manufacturing tolerances for fabrication

Production length (lf)	Production tolerance
150 - 1000 mm	± 2 mm
1001 - 4000 mm	± 3 mm
4001 - 10000 mm	± 5 mm
over 10000	± 10 mm

Production width	Production tolerance
< 100 mm	± 1,0 mm
> 100 mm	± 2,0 mm

Thickness	Production tolerance
0,9 / 1,0 / 1,2 / 1,6 / 2,0 / 3,0 / 4,0 mm	± 10% of the belt thickness

Manufacturing tolerances according to DIN EN ISO 15147 / DIN ISO 2768-m or DIN 16742-TG7. If you require tighter manufacturing tolerances for your application, we will be happy to check the possibility for you.



Technical request

Project		Phone		Name	
E-Mail		Address			

<input type="checkbox"/>	A	I'm looking for a replacement of an existing product. What performance would you like to improve:
<input type="checkbox"/>	B	I'm looking for a technical design support.

Please send to:
 Fax: +1 630 521 9836
 E-Mail: usa@behabelt.com

A

Product description (belt)		
Belt type, shape, size	Your sketch	
Hardness (Shore A or D)		
Type of surface		<input type="checkbox"/> smooth <input type="checkbox"/> matt <input type="checkbox"/> rough <input type="checkbox"/> textured <input type="checkbox"/> other:
Color		
Special product properties (FDA/EC, antistatic, UV, etc.)		
Supply of sample		<input type="checkbox"/> yes <input type="checkbox"/> no
Others		

Process description (conveyor)	
What is being done in the process?	
What products are being transported?	
What are the handled product properties?	
What happens before this process?	
What happens after this process?	

Conveyor layout			
Pulley diameters		Center distance	
Wrap angle		Belt speed	
Support or guide of belt		tensioning device/ take up amount	<input type="checkbox"/> yes, mm, <input type="checkbox"/> no
Max. belt load		numbers of belts that convey the load	

Environmental conditions			
What chemical requirements must the belt withstand?			
What is your cleaning procedure?			
Humidity / water	<input type="checkbox"/> normal <input type="checkbox"/> high <input type="checkbox"/> belt in water	UV-radiation	<input type="checkbox"/> yes <input type="checkbox"/> no
Is your belt subject to high abrasion?	<input type="checkbox"/> yes, due to:		<input type="checkbox"/> no
Environmental temperature (°C/°F)		Andere	

Needs assessment			
Order quantity (m/pc.)		Annual requirement (ft/pc.)	
Target Price		Standard coil length (ft)	
Packaging / coil form	<input type="checkbox"/> Wooden reel <input type="checkbox"/> Coil <input type="checkbox"/> Box <input type="checkbox"/> Cut to length <input type="checkbox"/> Special winding		

Basic information
for your inquiry

Basic information
for your inquiry



BEHA Innovation GmbH (Headquarters)

In den Engematten 16 · 79286 Glottertal/Germany
Phone: +49 7684 9070
E-Mail: info@behabelt.com · Internet: www.behabelt.com

BEHabelt USA

835 Bonnie Lane · Elk Grove Village · IL 60007 · USA
Phone: +1 630 521 9835 · E-Mail: usa@behabelt.com
Internet: www.behabelt.com

You can find us here

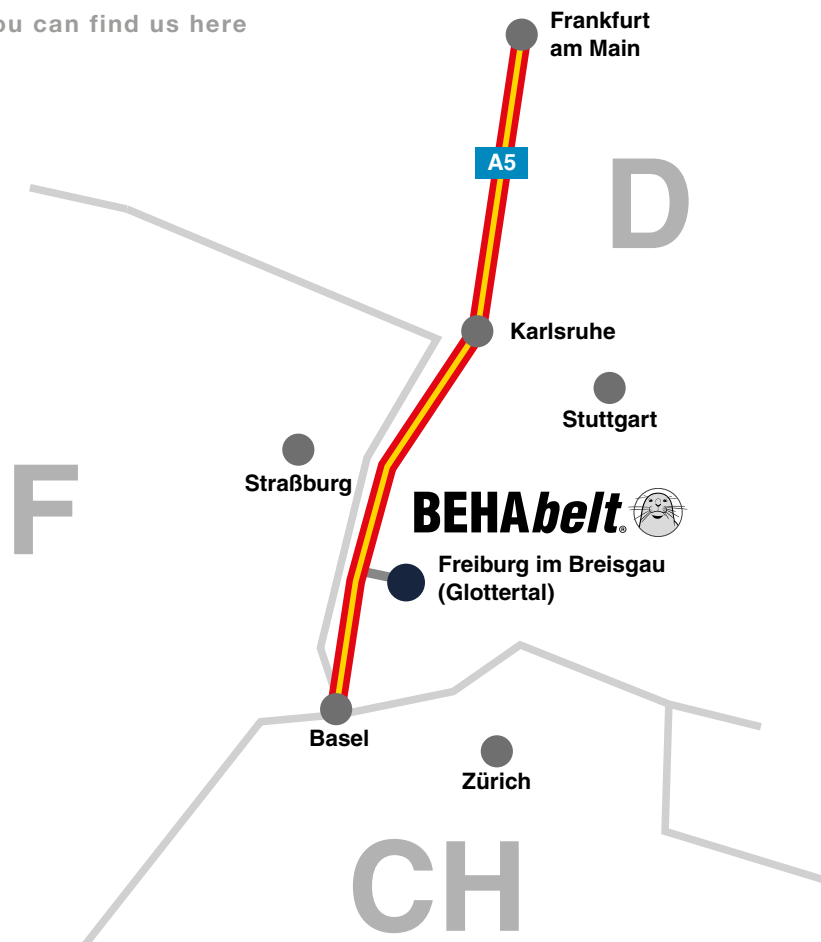

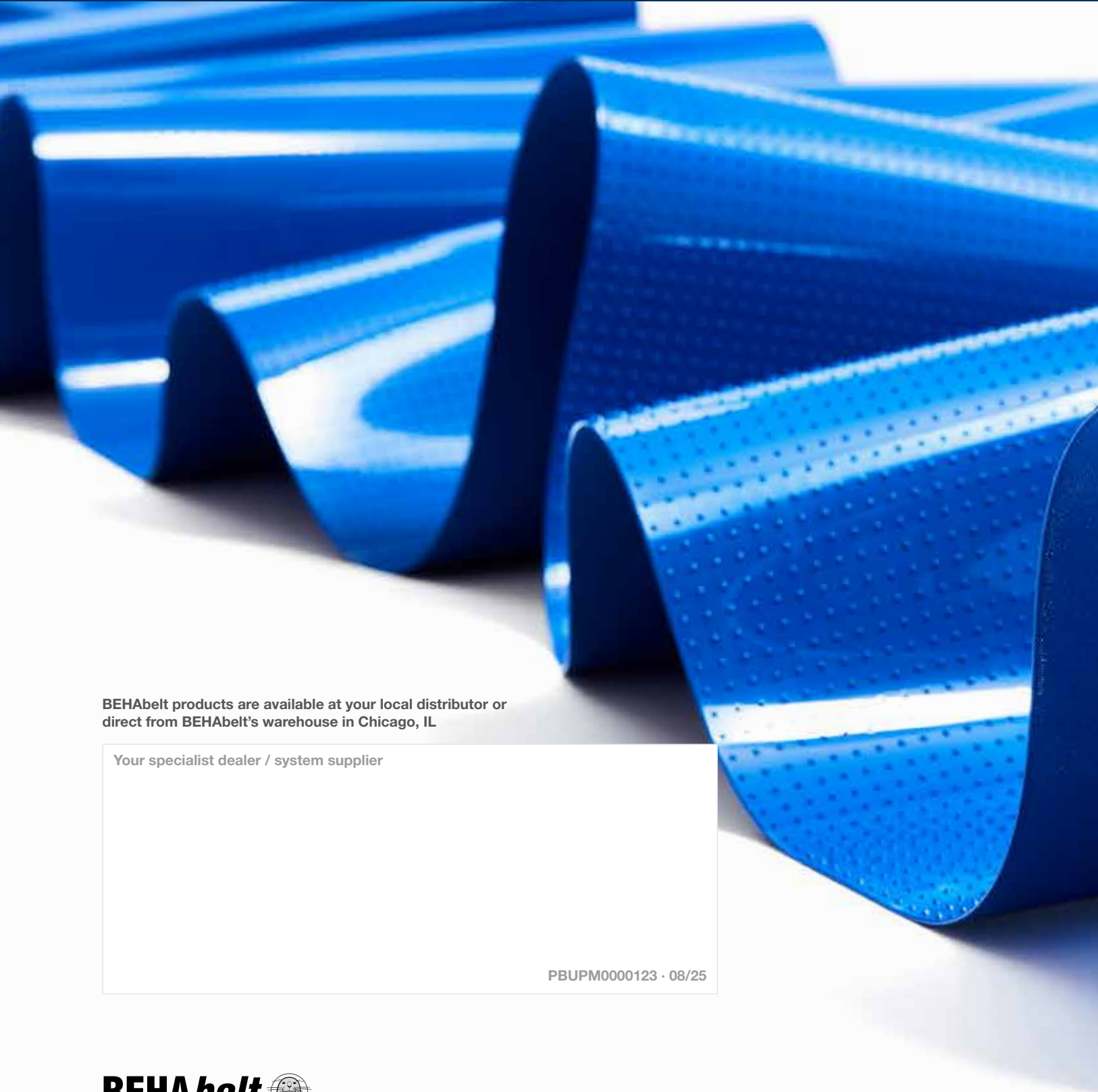

BEHAbelt products are available at your local distributor or direct from BEHAbelt's warehouse in Chicago, IL

Your specialist dealer / system supplier

PBUPM0000123 · 08/25

BEHAbelt 

BEHAbelt USA

835 Bonnie Lane · Elk Grove Village · IL 60007

Phone: +1 630 521 9835 · E-Mail: usa@behabelt.com · Internet: www.behabelt.com