

Belt tensioner RSH

BEHAbelt belt tensioner with attachment for pre-tensioning of Round and V-belts

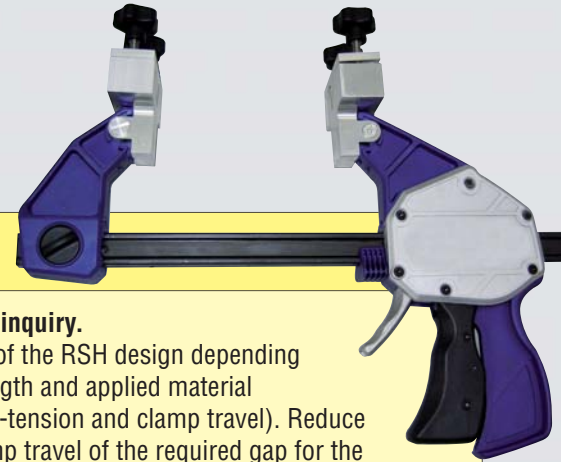

General information

The new BEHAbelt RSH belt tensioner simplifies and supports the tapering and welding of Round and V-belt directly within the application's machinery.

From end to end, its lightweight and practical design, the RSH belt tensioner is the best economical solution to pre-tension conveyor belts. With the unique multifunctional attachment you can tension both, Round and V-belts.

BEHAbelt RSH current design:

Design RSH01 450 mm (18") clamp travel, suitable up to approx. 3 m belt length



Design RSH02 900 mm (36") clamp travel, suitable up to approx. 9 m belt length

Larger designs on inquiry.

You have a choice of the RSH design depending on the total belt length and applied material (recommended pre-tension and clamp travel). Reduce the theoretical clamp travel of the required gap for the welding tool (approx. 200 mm).

- ⚠ Please observe the instruction manual along with the safety and caution notes on the rear carefully before you use the RSH.

Suitable for the following profiles*:

Dimension	PU75	PU80	PU85	PU90	TPE 40D	TPE 55D
	max. pretension 8%	max. pretension 8%	max. pretension 8%	max. pretension 6%	max. pretension 4%	max. pretension 4%
Round belts \varnothing 6 - 10 mm	OK	OK	OK	OK	OK	OK
Round belts \varnothing 10 - 15 mm	OK	OK	OK	no	no	no
V-belts  10 x 6 / 13 x 8 mm	OK	OK	OK	OK	OK	OK
V-belts  17 x 11 mm	OK	OK	OK	no	no	no

* compliant to the known mechanical material characteristic of BEHAbelt products from the 8/18/2009
* without reinforcement alternative

Work sequence

- 1) Cut belt to approximate belt length (a little longer)
- 2) Extend belt tensioner to max. clamp travel
- 3) Insert both belt ends
- 4) Mark the belts to read out the corresponding pretension (100 mm or rather 100 cm)
- 5) Pretension the belts (see safety notes)
- 6) Cut belt ends straight
- 7) Install the welding technique
- 8) Weld belt ends together
- 9) Remove the welding tool
- 10) Leave the belt within the belt tensioner to cool off
- 11) Remove the belt tensioner



Belt tensioner RSH

Safety and caution explanation

Safety notes

- ⚠ The RSH belt tensioner was built in accordance with the current state of technology and accepted safety-standards. Nevertheless, threats to life and limb of the operator or a third party or damages of the instrument and other values can occur through the application (or misuse) of the machine.
- ⚠ The listed operation ranges of the RSH are simply recommendations. The user has to check the suitability of the RSH for every particular application. The original maximum load (technical specification) noted by the manufacturer of the belt tensioner is not effective any more according to the reconstruction of the attachment.
- ⚠ Operation of the instrument should only occur in perfect working condition, for its intended use, with strict adherence to operating instructions contained within this manual!
- ⚠ The RSH is only intended to pre-tension profiles and belts made of PU and Polyester. Other applications of the instrument are considered to be unconventional, and therefore a misuse of the device. The manufacturer is not liable for any resultant damages or secondary damages of unintended use, the user bears all liability. The intended use also includes the consideration of the instructional manual and adherence to inspection and attendance loads.
- ⚠ Always keep the instructional manual ready to hand at the site of use /application!
- ⚠ Employees which handle the instrument have to read the instructional manual carefully in advance, especially the chapter regarding safety instructions!
- ⚠ Do not make any changes or reconstructions which can influence the security of the belt tensioner without prior written approval of the manufacturer!

!!! NOTE !!!

Make sure that during the tensioning process an adequate clamping force is applied (for clamping the belts with the attachment) to avoid sudden loosening of the belts. Check the tension force within the attachment constantly during the tensioning process. We recommend a re-tensioning of the belts during the tensioning process.

Intended use

The appliance may only be used under those conditions and for those purposes for which it was constructed. In particular the safety notes (⚠ work sequence) and use in a dry environment must be observed.

- ⚠ Operational safety is no longer guaranteed if the appliance is modified or converted.

The construction of this manual was provided with great accuracy. Liability for light careless misuse errors e.g. misprint is also excluded.

All rights are reserved. It is not permitted to reproduce or publish any part of this application manual (print, photocopy or any other system of reproduction) without prior explicit written approval from BEHA Innovation.

BEHAbelt USA

1400 North Mittel Blvd, Suite B,
Wood Dale IL 60191, USA
Phone: +1 630 521 9835
Fax: +1 630 521 9836
e-mail: usa@behabelt.com
internet: www.behabelt.com

